



# Dual Pump Module Harness & Relay Kit

## Part # 12-759

### Installation Instructions

#### INTRODUCTION:

Congratulations on your purchase of the Holley Fuel Pump Relay Kit. Holley Performance Products cannot and will not be responsible for any alleged or actual engine or other damage, or other conditions resulting from misapplication of the fuel pump relay kit described herein. However, it is our intent to provide the best possible products for our customer; products that perform properly and satisfy your expectations. Should you need information or parts assistance, please contact our Technical Service Department at 1-270-781-9741, Monday through Friday, 7 a.m. to 5 p.m. Central Time. Please have the part number of the product you purchased when you call.

**WARNING! THESE INSTRUCTIONS MUST BE READ AND FULLY UNDERSTOOD BEFORE BEGINNING INSTALLATION. FAILURE TO FOLLOW THESE INSTRUCTIONS MAY RESULT IN POOR PERFORMANCE, VEHICLE DAMAGE, PERSONAL INJURY OR DEATH. IF THESE INSTRUCTIONS ARE NOT FULLY UNDERSTOOD, INSTALLATION SHOULD NOT BE ATTEMPTED. PLEASE CONSULT HOLLEY TECH SERVICE OR A QUALIFIED MECHANIC.**

**WARNING! Check for any fuel leaks before starting vehicle.**

Route the wires away from heat and sharp metal edges that may cause melting or damage to the wires. Use crimping tools or solder and heat shrink tubing when making wiring connections. Do not use electrical tape to hold the wires together.

For each relay follow the procedure below, there is one relay for each fuel pump module.

1. Disconnect ground terminal of the battery.
2. For best results, mount the relay as close as possible to the pump module.
3. Mount the relay to the vehicle using existing hardware or with a sheet metal screw. The mounting hardware can also be used to provide ground to the relay trigger by attaching the BLACK 16-gauge wire that corresponds to pin 86 on the relay – as long as the hardware is mounted to a good vehicle ground (i.e. metal chassis or body of the vehicle). The BLACK wire can also be mounted in another location to provide a good known ground.
4. Using the included heat shrink connectors, connect the RED 12-gauge wire that corresponds to pin 30 on the relay to a constant 12V source. The positive terminal of the battery is recommended.
5. Splice the fuse holder onto the RED 12-gauge wire that corresponds to pin 30 on the relay and insert the fuse into the fuse holder.
6. Using the included step down butt connector (yellow w/ blue band), connect the RED wire that corresponds to pin 87 on the relay to the RED wire on the vehicle harness included with your fuel pump. The side of the butt connector that has the blue band should be attached to the wire on the pump module vehicle harness.
7. The GREEN 16-gauge wire is the relay trigger. This **MUST** be connected to the OEM wire used to power the OEM fuel pump. This will ensure that the Holley modules are turned on and off properly like the OEM module. Extra connectors are provided for this purpose.
8. Reconnect the ground terminal of the battery.

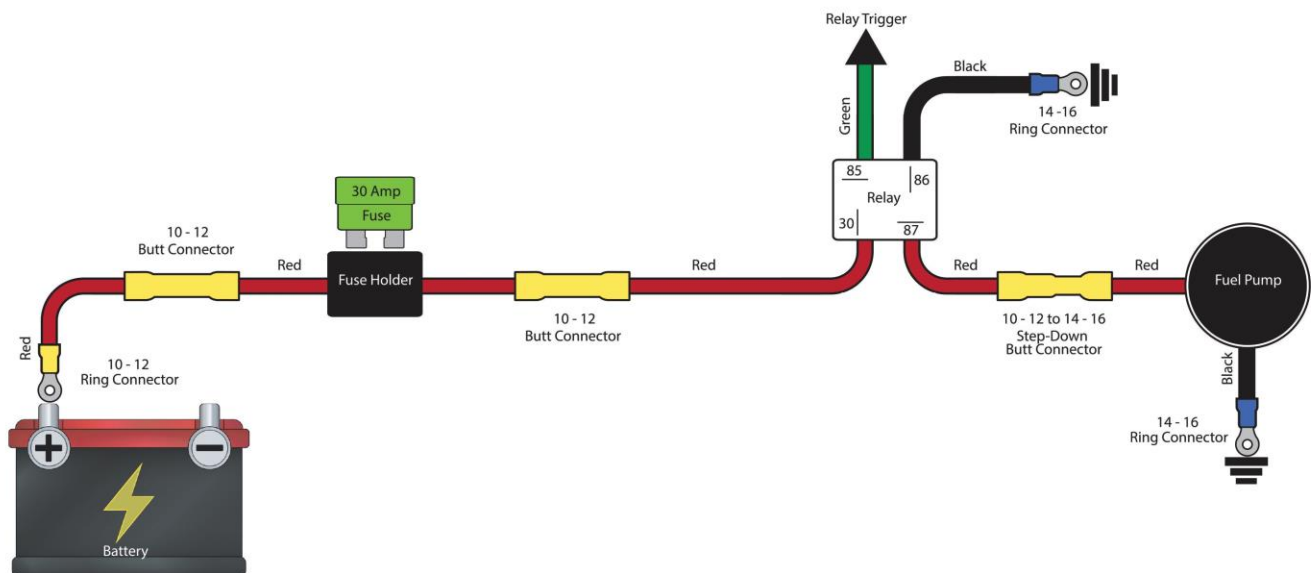

199R12048  
Date: 4-6-20