



OIL PANS P/N 302-24 & 302-24BK

Instruction Sheet 199R12503

WARNING! These instructions must be read and fully understood before beginning installation. Failure to follow these instructions may result in poor performance, vehicle damage, personal injury, or death. If these instructions are not fully understood, installation should not be attempted.

INTRODUCTION:

Holley® Performance Products has written this instruction sheet for the installation of the **LT Off-road Oil Pan**. This instruction sheet contains all the information needed to install the oil pan. Please read all the **WARNINGS** and **NOTES**, as they contain valuable information that can save you time and money. Holley® Performance Products cannot and will not be responsible for any alleged or actual engine or other damage, or other conditions resulting from misapplication of the oil pan described herein. However, it is our intent to provide the best possible products for our customer; products that perform properly and satisfy your expectations.

APPLICATIONS:

These Holley® Off-road oil pans are for LT engine retrofit installation in 1973-87 GM K10 with stock or lifted/modified suspensions. They are compatible with all popular transmissions (SM465, NV4500, TH350, TH400, 700R4, 4L60-4L70, 4L80, 6L80, and 6L90).

IMPORTANT APPLICATION NOTES:

- These oil pans provide OEM fitment and oil filter mounting provisions.
- Not intended to be used with engines that originally utilized a dry sump system.
- Allows for strokes up to 4.0".

The Holley® LT Swap oil pans are designed to work with an LT1 dipstick and tube (if desired). Below are the part numbers:

- LT Dipstick – GM P/N 12658475
- LT tube – GM P/N 12661062

PAN CAPACITIES:

Sump Oil Capacity –	5.6 Qts.
Total Oil Capacity w/ stock filter –	6.1 Qts.

PARTS NEEDED:

- High Quality Gray RTV sealer (GM P/N 12378521 or equivalent)
- Thread sealant (Loctite® brand 567 pipe thread sealant or equivalent)
- Thread locking compound (blue Loctite® or equivalent)
- Oil Filter (AC Delco® PF64 or equivalent)
- Oil

REMOVAL:

1. Remove the oil level indicator tube.
2. Remove the bolt and the left rear transmission cover.
3. Remove the starter motor assembly.
4. Remove the engine oil cooler adapter.
5. Remove the bolt and right transmission cover.
6. Disconnect the engine oil level sensor electrical connector. This sensor will not be utilized in the Holley pan.
7. Remove the bolts from the bell housing to the oil pan.
8. Remove the oil pan bolts.
9. Remove the oil pan from the engine block.

IMPORTANT: All gasket surfaces should be free of oil or other foreign material during assembly. Inspect the engine block oil gallery passages to make sure they are free from any debris or restrictions.

IMPORTANT: It is advisable to wash all of the new parts well before installing to remove any dirt or debris from the packing and shipping process.

IMPORTANT: It is advisable to test-fit the oil pan to the engine before installation to ensure that the crankshaft and connecting rods clear the windage tray, oil pump pick-up screen, and the oil pan, making a full revolution of the rotating assembly by hand.

IMPORTANT: It is advisable to mock up the engine and oil pan in the intended vehicle to ensure there is no contact of the pan to the frame or crossmembers.

INSTALLATION:

IMPORTANT! Thoroughly clean all components before assembly to remove any/all contaminants.

1. Remove the new Holley® oil pan, parts kit, pickup screen, windage tray, and baffle from the box.

WARNING! Push a flexible brush all the way through the pan's internal passage to ensure it is clean and unobstructed. Any obstruction can affect oil pressure and damage the engine. See photo below.

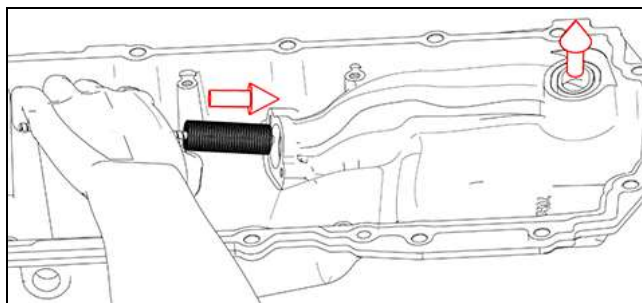

2. Pre-assemble pan.

Apply a drop of Loctite® to the threads of the (x4) supplied M6 x 12mm flange head bolts and use them to install the baffle into the oil pan. Torque the (x4) bolts to 10 ft./lbs.

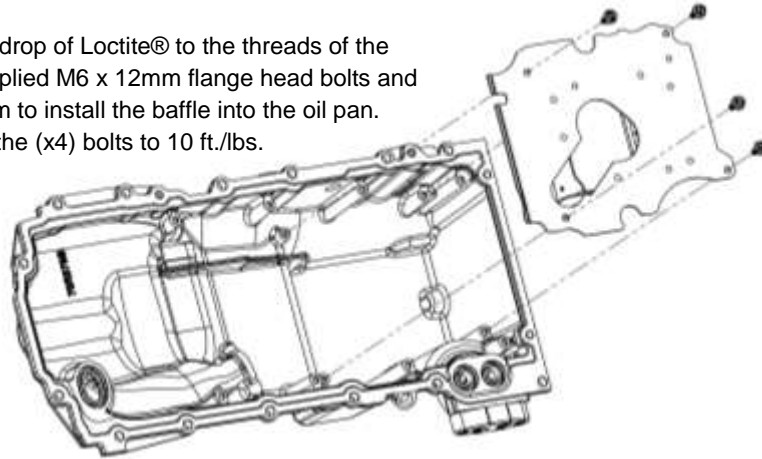

Standard baffle not used when installing 302-34



Reinstall the oil screen/pickup tube and gasket with supplied (x2) M6 x 16 flange head bolts. Apply a drop of blue Loctite® to the threads before installing. You may need to slightly adjust the bracket to provide precise alignment of the hole. Torque the bolts to 10 ft./lbs.

NOTE: Holley recommends replacing the pickup gasket with P/N 108-210.

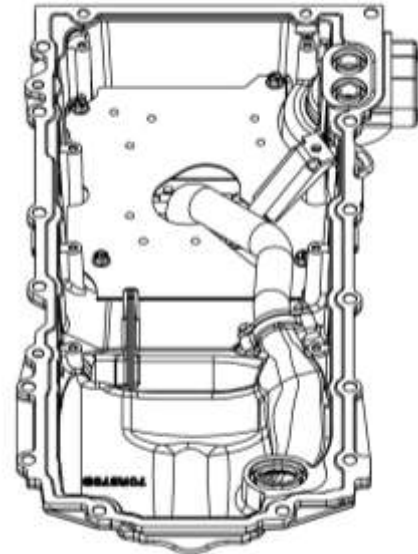
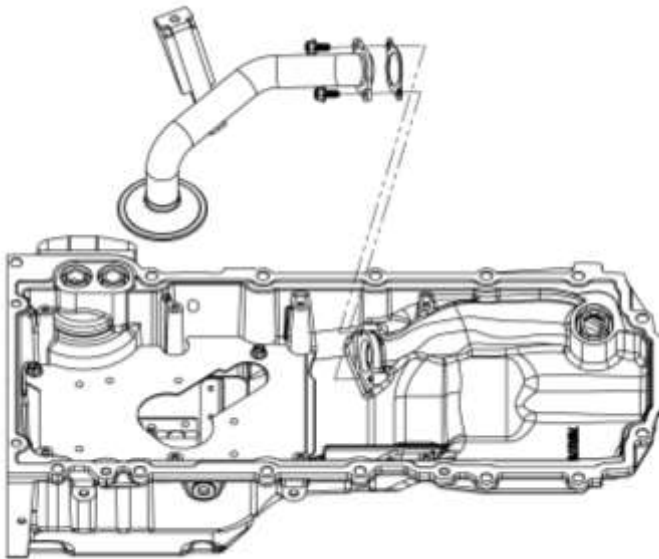

IMPORTANT: While the bolts are started, but still loose, lift the pickup tube. Tighten the two bolts while maintaining the lifted position. This process ensures proper clearance between the pickup inlet and the pan floor.

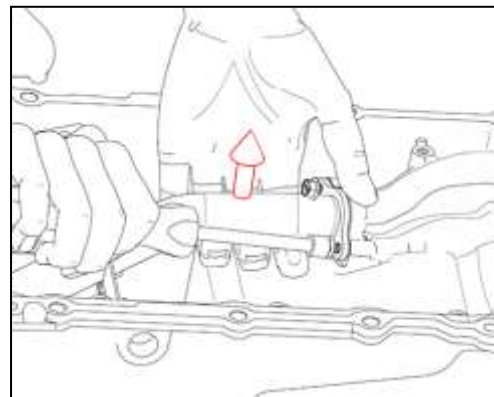

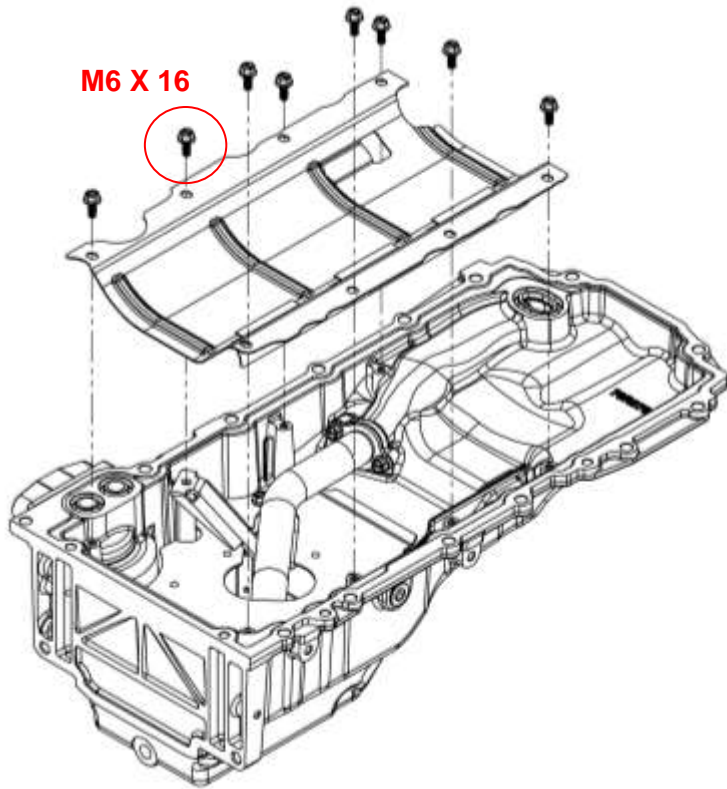

M6 X 16

Reinstall the windage tray. Apply a drop of blue Loctite® to the threads of the supplied (x7) M6 x 12 flange head bolts. Install the (x1) M6 x 16 flange head bolt in the location that also goes through the pickup tube bracket. Torque the bolts to 10 ft./lbs.

Confirm the two oil filter passage seals are still in place.

Replace as needed with GM P/N 12621086

Confirm pickup to oil pump seal is still in place. **WARNING:** This seal must be oriented as pictured.

Replace as needed with GM P/N 12622368

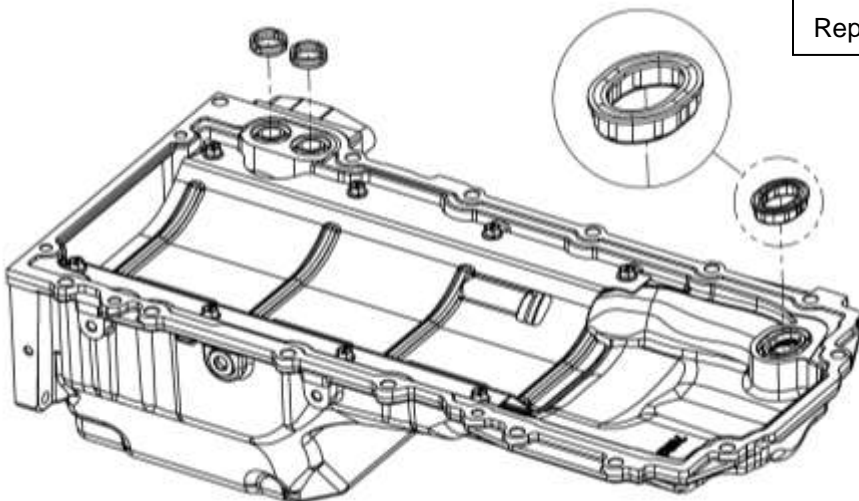

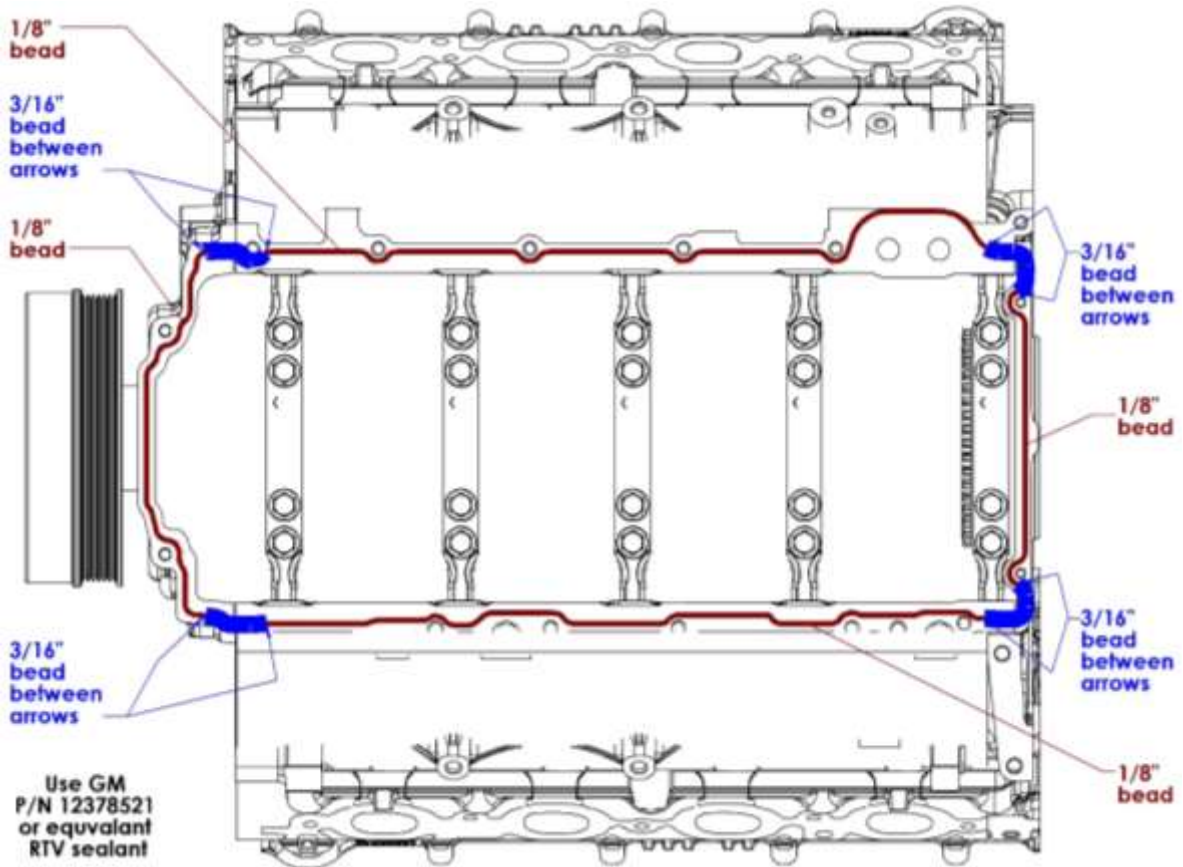

3. Apply a bead of RTV sealant (GM P/N 12378521 or equivalent) in the amount shown above.
4. Position the oil pan in place on the engine block.

NOTE: Pan will locate on pan's two dowel pins.

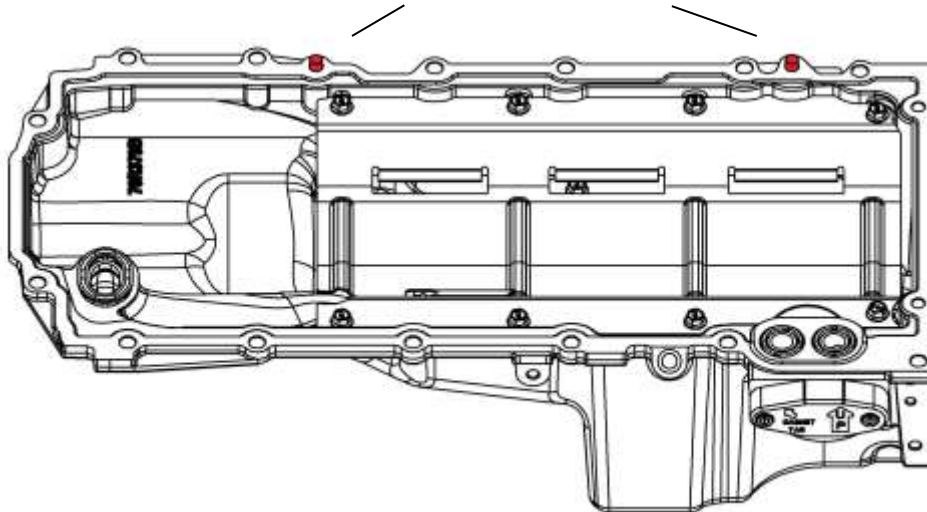

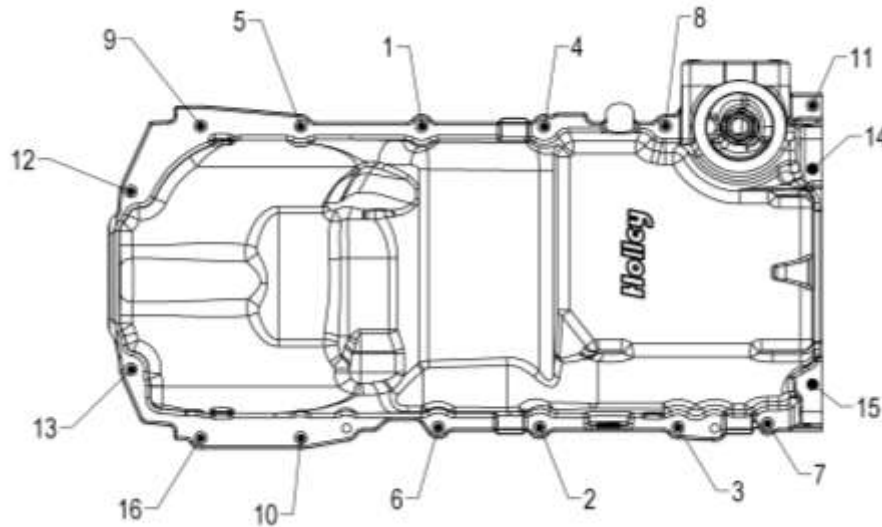

Torque:

M8 bolts to 18 ft./lbs. (bolts 1 through 13, and 16)

M6 bolts to 106 in./lbs. (bolts 14 and 15)

5. Reinstall the mounting bolts for the oil pan assembly.
6. Tighten the oil pan mounting bolts to 18 ft./lbs.
7. Tighten the oil pan mounting bolts M6 to 106 in./lbs.
8. Reinstall the bell housing to oil pan bolts. Tighten the bolts to 37 ft./lbs.
9. Reinstall the starter assembly.
10. Reinstall left and right rear transmission cover and bolt.

NOTE: Tighten the transmission cover bolt to 106 in./lbs.

11. Reinstall the oil level indicator tube. Confirm O-ring seal is in place. If tube is not new, replace tube seal before installation.

NOTE: Tighten the tube bracket bolt to 88 in./lbs.

12. Fill the crankcase with the proper quantity and grade of oil. Be careful not to overfill with oil.
13. Start the vehicle and check for leaks and adequate oil pressure. Use the dipstick to verify the oil level. This should read full after 6 quarts of oil with a new filter.

302-35 Off-Road Rock Shield - The 302-35 Off-Road Rock Shield works with P/N 302-4, 302-4BK, 302-24 & 302-24BK oil pans.

INSTALLATION:

1. Pre-assemble main shield components. Tighten fasteners down completely; ensuring that the head of the carriage bolt is flat against the sheet metal, then loosen nuts 1 turn.

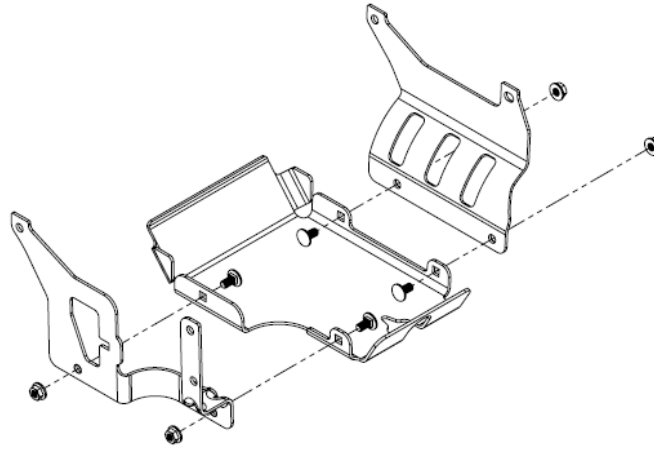

2. Bolt the shield assembly onto oil pan using the M8 x 16 Flange Head Bolts, leaving them finger tight.

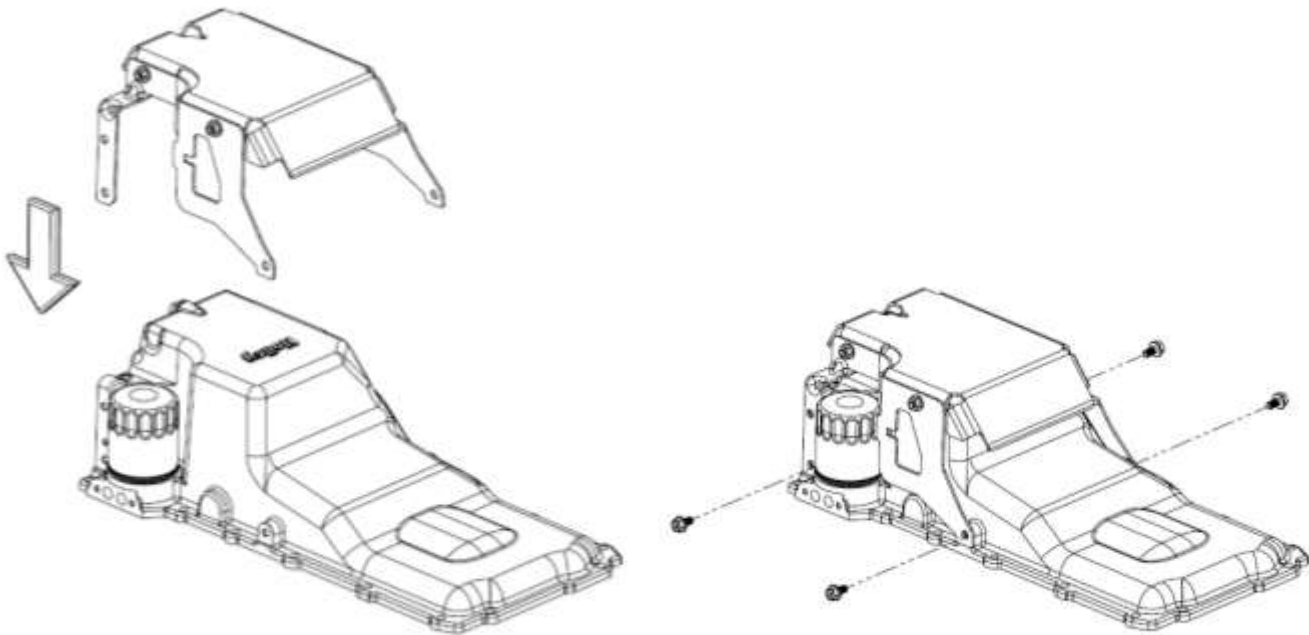

NOTE: Starting with the bolts and then the nuts. Torque fasteners to 18 ft./lbs.

3. Install oil filter guard by first installing the carriage bolt and nut to the cover. Leaving them loose, slide the carriage bolt shoulder into the slot on the pan guard and then install the M8 x 20 bolts in the rear mounting hole.

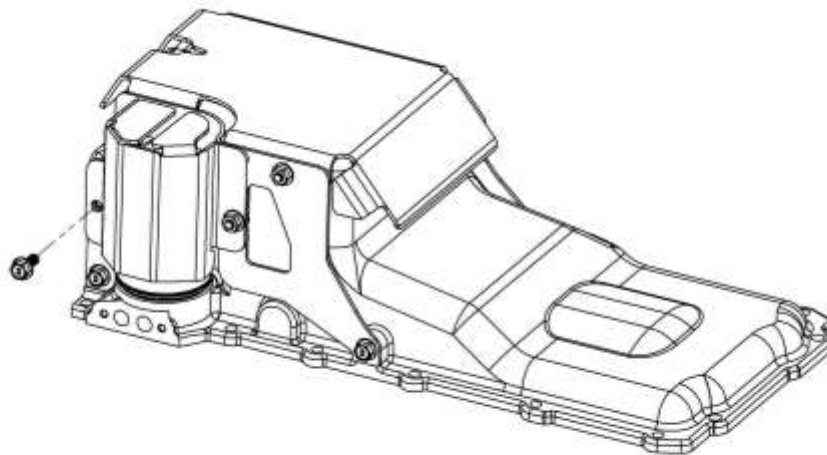
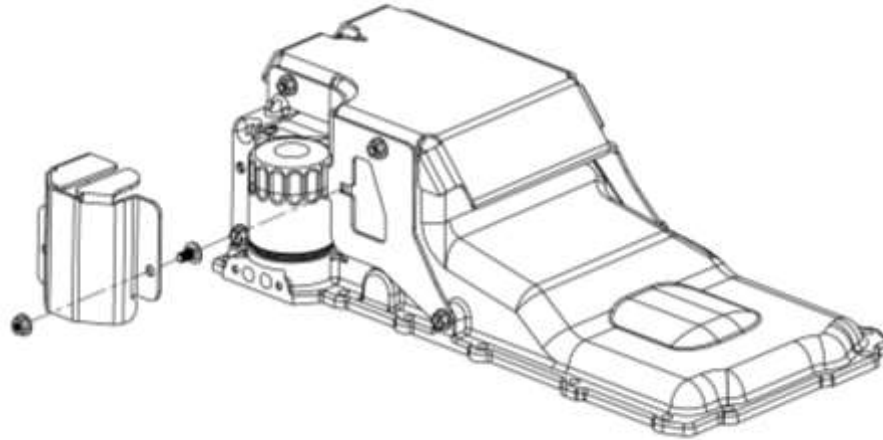

NOTE: Starting with the bolt, torque fasteners to 18 ft./lbs.

Holley® Technical Support
1801 Russellville Road
Bowling Green, KY 42101
866-464-6553
www.holley.com

© 2023 Holley Performance Products, Inc. All rights reserved. Tous Droits Réservés.

199R12503
Revision Date: 8-31-23