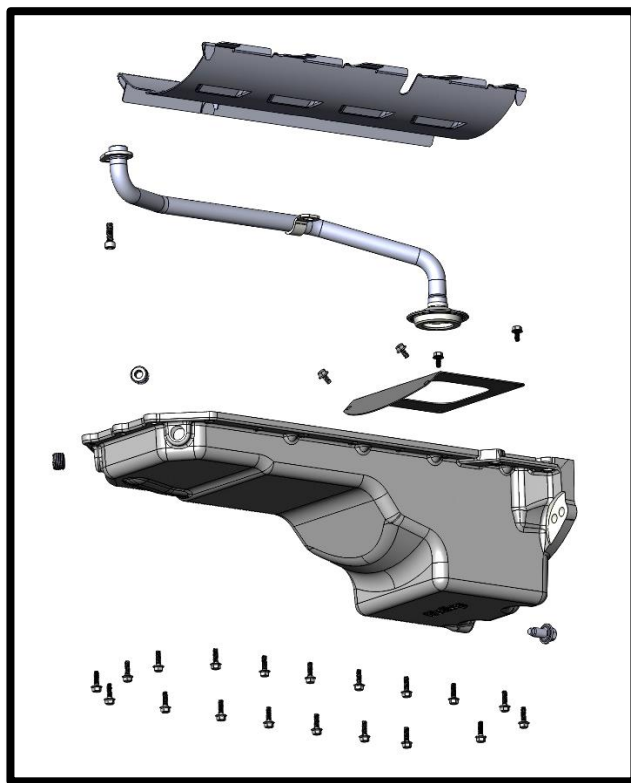




## HOLLEY® Gen. 3 Hemi, Cast Rear-Sump Oil Pan Installation Instructions



<b>302-63 &amp; 302-63BK</b>	OIL PAN, HEMI 6.2 SC, REAR-SUMP RETROFIT
<b>302-75 &amp; 302-75BK</b>	OIL PAN, HEMI NON-VVT, REAR-SUMP RETROFIT
<b>302-76 &amp; 302-76BK</b>	OIL PAN, HEMI VVT, REAR-SUMP RETROFIT

**NOTE: Read all instructions carefully before attempting the installation.**

### APPLICATIONS:

- Retro-fit vehicles
  - 1972-93 D-100
  - 1987-96 1<sup>st</sup> Gen. Dakota
  - 1997-2004 2<sup>nd</sup> Gen. Dakota
- Engine
  - Hemi, Gen. 3 6.2 SC (302-63 includes required pickup tube for this application)
  - Hemi, Gen. 3 without VVT (302-75 includes required pickup tube for this application)
  - Hemi, Gen. 3 with VVT (302-76 includes required pickup tube for this application)

### OIL CAPACITY (APPROXIMATE):

- Sump Oil Capacity – 6.2 Quarts
- Total Oil Capacity with stock oil filter - 6.7 Quarts

## PARTS INCLUDED:

- ❑ 1 – Cast Aluminum Oil Pan, W/O-rings installed
- ❑ 1 – Windage Tray (works with all strokes up to 4.060")
- ❑ 1 – Baffle
- ❑ 1 – Pickup Tube & Pickup Tube O-ring (VVT or NON-VVT model)
- ❑ 1 – M12 x 1.75 Drain Plug w/O-ring
- ❑ 4 – M6 x 1, 12mm Length Hex Flange Head Bolt (Baffle Bolts)
- ❑ 21 – M6 x 1, 20mm Length Hex Flange Bolt (Oil Pan to Engine Bolts)
- ❑ 1 – M8 x 1.25, 24mm length Socket Head Cap Screw, (Pickup Tube To Oil Pump)
- ❑ 2 – Plug, 1/2-14 NPT (Only on versions with drain back ports)

## PARTS NOT INCLUDED, BUT REQUIRED:

- Crankshaft Cap Stud for Pickup -  
Most engines have this stud (see **FIGURE "E"** on page 3). If your engine is a 5.7 originally with a car front sump pan, Mopar P/N 06513100AA must be purchased.
- Dipstick –  
Works with most factory and aftermarket dipsticks:
  - Recommended, Holley P/N 302-74 Gen III Hemi oil pan dipstick that has been designed to work in most Dodge trucks with Gen III Hemi swaps.
  - Alternative, any dipstick from a Dodge or Ram truck that was originally equipped with a Gen III Hemi is compatible with this pan. These dipsticks mate to the engine block dipstick port. **NOTE: Fitment not guaranteed when using aftermarket exhaust.**

## RECOMMENDED TOOLS:

In/lb & ft/lb Torque Wrench	1/4" or 3/8" Sockets	1/4" or 1/2" Ratchets
3/8" or 1/2" x 6" Extension	Jack Stands	Floor Jack
Box Cutter or Small Knife	RTV Silicone Gasket Maker	Brake Cleaner or equivalent
Thread Cleaner Tool	Torque Angle Gauge	

## BEFORE STARTING:

Place the vehicle in an adequately lit and ventilated location where the floor is solid and flat. DO NOT work on a hot engine. Heat causes metal to expand and makes the removal of fasteners more difficult. Please be sure to wear the proper safety equipment; eye goggles and gloves are recommended to ensure a safe installation.

**WARNING – Be sure to inspect and clean all parts before installation**

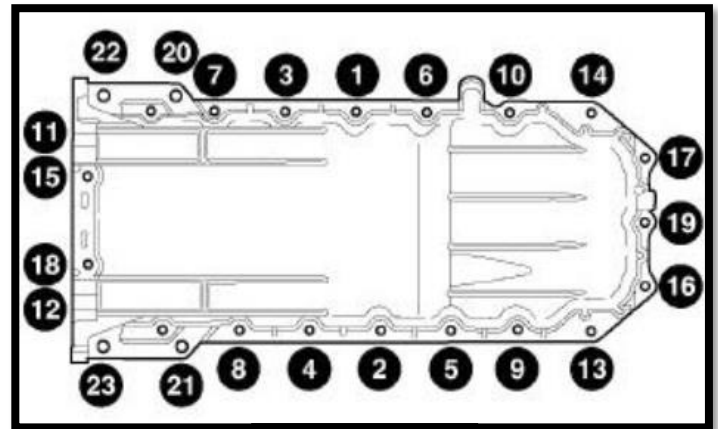
**NOTE - Read Instructions prior to installation.**

# REMOVAL OF FRONT SUMP "CAR" OEM OIL PAN & PICKUP TUBE

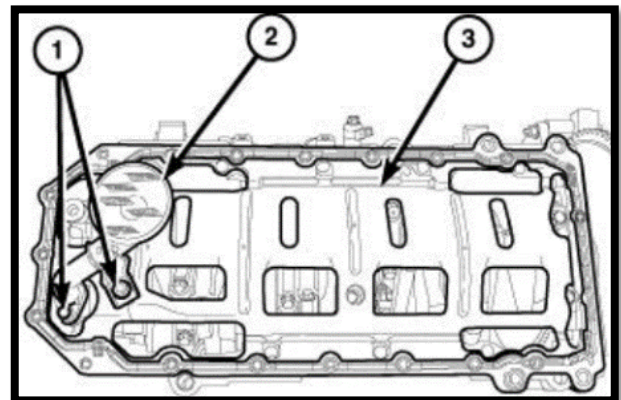
1. Unbolt and remove the oil dipstick tube from oil pan, located between retaining bolts 6 and 10 (See **Figure "A"**). Once unbolted, pull up firmly to remove oil dipstick tube.

**NOTE: Do not pry on the oil pan or oil pan gasket. The oil pan gasket is integral to the engine windage tray and does not come out with the oil pan.**

2. Remove the M10 retaining bolts (Horizontal 11, 12, 15, & 18 and vertical 20, 21, 22, & 23 – see **FIGURE "A"**) from the rear of the oil pan to the transmission.
3. Remove starter motor assembly.
4. Remove the engine oil cooler adapter.
5. Remove the M6 retaining bolts and remove the oil pan.
6. Remove the oil pump pickup tube retaining bolt and nut (**FIGURE "B" – Bubble #1**). Nut will only be on the 6.4L engine in car applications.
7. Remove the oil pump pickup tube. (**FIGURE "B" – Bubble #2**).
8. Remove and discard the oil pan gasket/windage tray (**FIGURE "B" – Bubble #3**).
9. **Remove the oil indicator tube plug (**FIGURE "C" – Bubble #1**) from the engine block using a punch.**



**FIGURE "A"**



**FIGURE "B"**

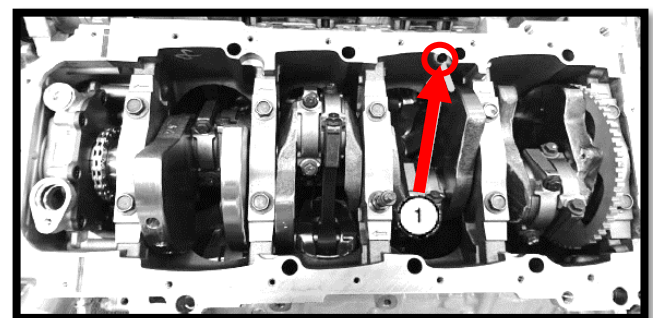
**NOTE: CUSTOMER USING FRONT SUMP "CAR" 5.7 HEMI WILL NEED TO PURCHASE MOPAR PART # 06513100AA "MAIN CAP DOUBLE ENDED STUD" TO USE IN THE FOLLOWING STEPS (SHOWN IN **FIGURE "D"**).**

10. **6.4L HEMI:** Remove the main cap double ended stud (**FIGURE "E" – Bubble #9**) and the middle main cap bolt (**FIGURE "E" – Bubble #1**).

**5.7L HEMI:** Remove the middle main cap bolt.

11. **6.4L HEMI:** Reinstall the main cap bolt removed from the middle to the first location (**FIGURE "E" – Bubble #1**). **6.4L HEMI:** Reinstall the main cap bolt removed from the middle to the first location (**FIGURE "E" – Bubble #1**). Install the new main cap double ended stud to the middle location (**FIGURE "F" – Bubble #2**). Torque to 28 N·m (21 ft. lbs.) then rotate the main cap bolt and double ended stud an additional 90° turn.

**5.7L HEMI:** Install the new main cap double ended stud to the middle location (**FIGURE "F" – Bubble #2**). Torque to 28 N·m (21 ft. lbs.) then rotate the main cap double ended stud an additional 90° turn.



**FIGURE "C"**



**FIGURE "D"**

**\*FIGURES "E" & "F" SHOWN ON NEXT PAGE\***

## REMOVAL OF FRONT SUMP "CAR" OEM OIL PAN & PICKUP TUBE - CONTINUED -

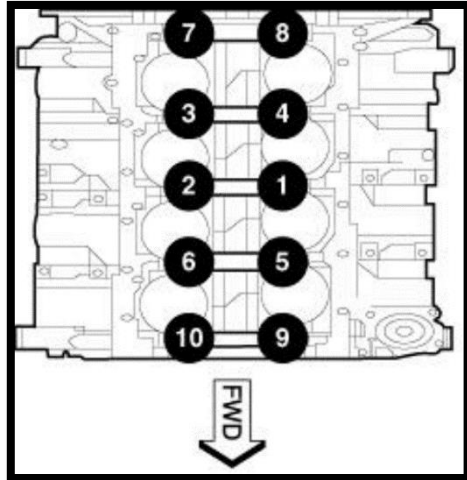


FIGURE "E"

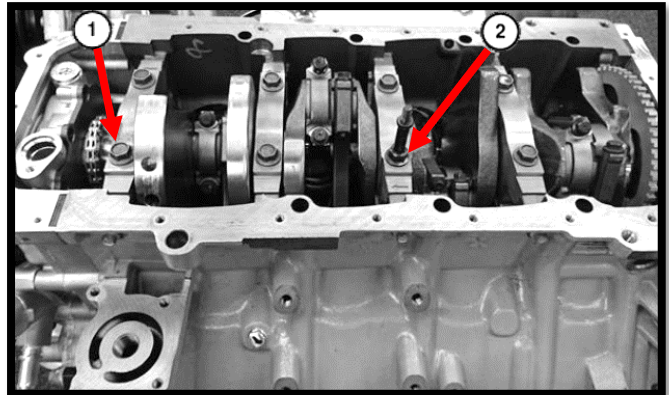


FIGURE "F"

## REMOVAL OF REAR SUMP "TRUCK" OE OIL PAN & PICKUP TUBE

1. Remove starter motor assembly, if installed.
2. Remove the engine oil cooler adapter, if installed.
3. Unbolt and remove oil dipstick from block. Dipstick located between retaining bolts 7 & 3 (See **Figure "G"**).
4. Remove the M6 retaining bolts and remove the oil pan. (**FIGURE "G" Bubble #1 through 20**) **NOTE: Do not pry on the oil pan or oil pan gasket. The oil pan gasket is integral to the engine windage tray and does not come out with the oil pan.**
5. Remove the oil pump pickup tube retaining bolt and nut (**FIGURE "H" – Bubble #2**).
6. Remove the oil pump pickup tube. (**FIGURE "H" – Bubble #1**).
7. Remove and discard the oil pan gasket/windage tray.

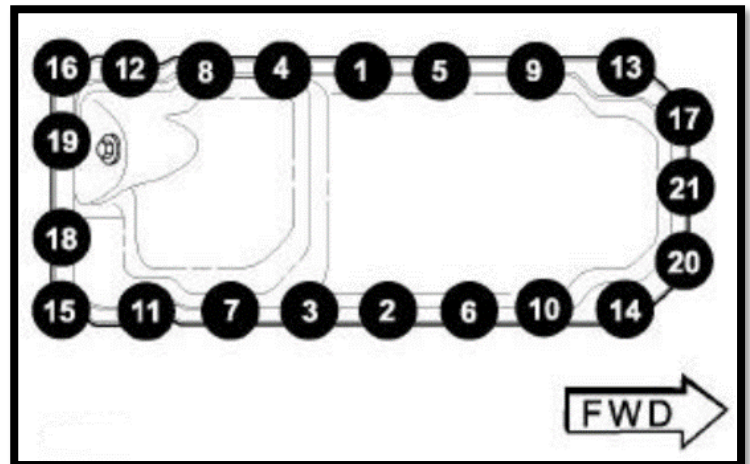


FIGURE "G"

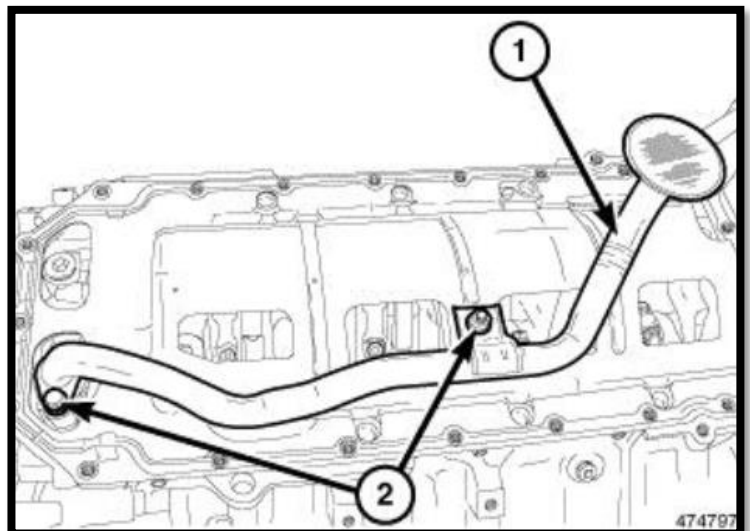
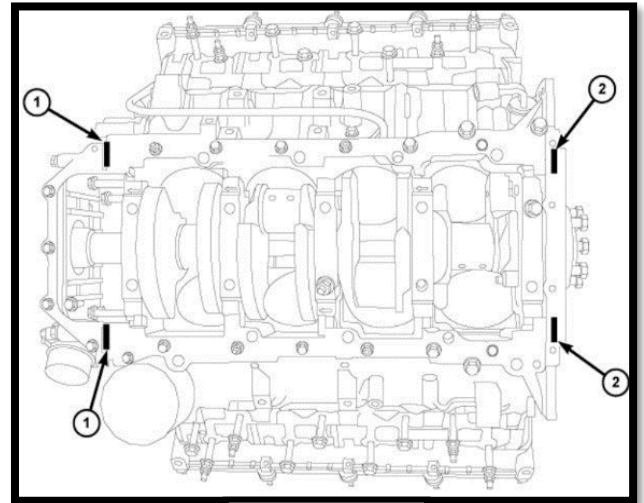


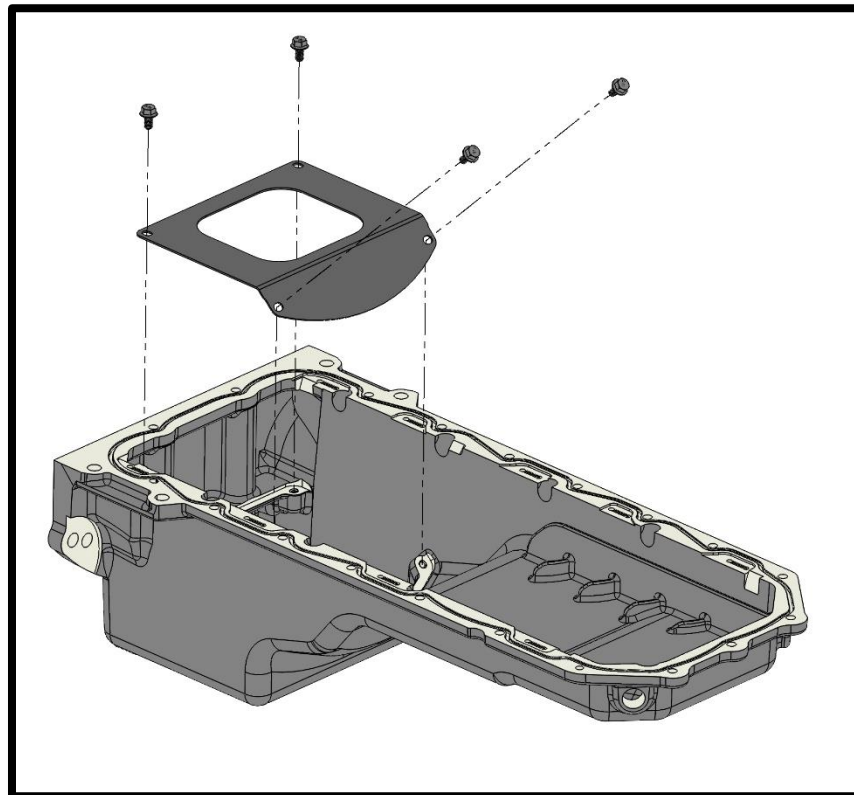
FIGURE "H"

# HOLLEY RETRO FIT OIL PAN INSTALLATION

1. Clean engine block oil pan mating surface. Take care to remove the old RTV residue at the locations shown in **FIGURE "J"**. For best installation results, clean threads with a bottoming tap or thread cleaner tool and blow out with compressed air. Clean away any residual gasket material or sealing compound.
2. Take time to check and make sure oil pickup tube provided fits your application (VVT or NON-VVT). Test fit the pickup tube on the engine. The tube flange should fit square to the oil pump while the tube bracket should align to the main bearing stud. If pickup tube does not fit as described, confirm the correct oil pan part # was ordered for your application.
3. Clean all components to make sure they are clean and free of any debris.
4. Pre-assemble the pan by installing the baffle in orientation and location as shown in **FIGURE "K"**. Apply a drop of blue thread locker to the threads of the (x4) supplied M6 x 1 12mm long cap screws. Torque the (x4) baffle bolts to 8-10 ft./lbs. The dipstick deflector is not used for this application.

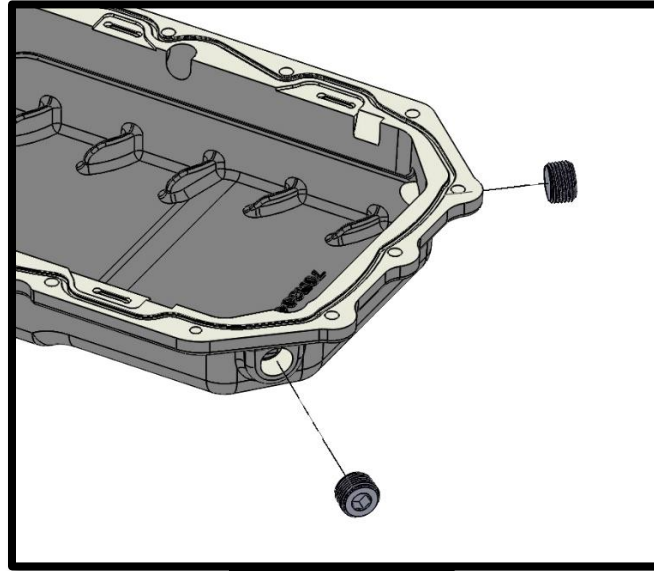


**FIGURE "J"**



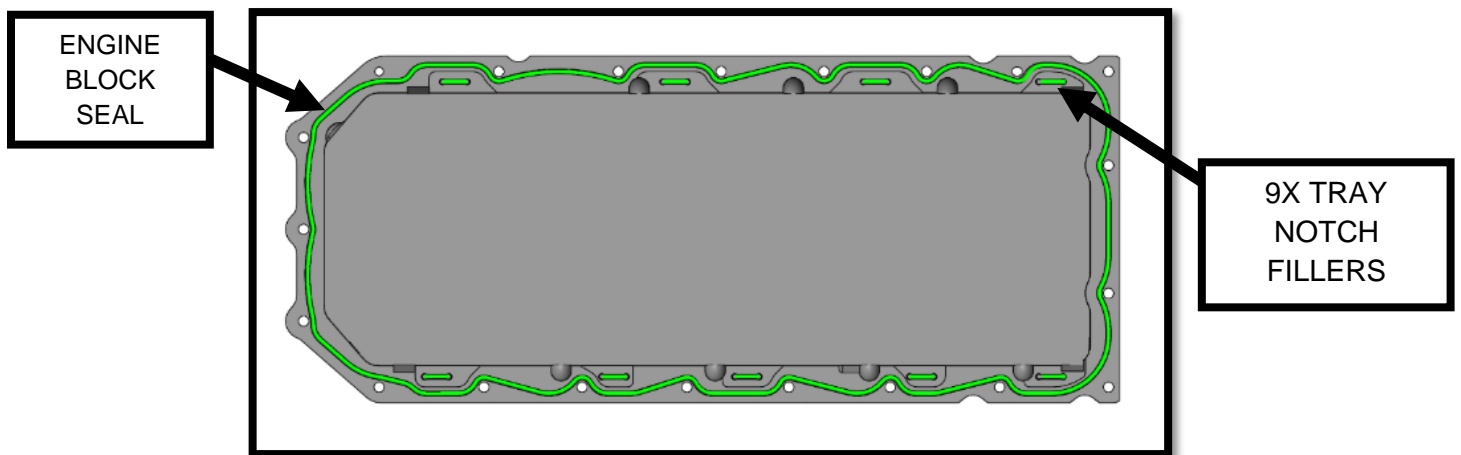
**FIGURE "K"**

5. If your oil pan is equipped with turbo drain back ports; they will be located at the front on both driver and passenger sides. If these ports will not be utilized, install the supplied ½-14 NPT plugs (x2) with PTFE thread sealer. Shown in **FIGURE "L"**.



**FIGURE "L"**

6. The O-rings shown in green in **FIGURE "M"** should be already be installed. There should be a split in the main O-ring that was glued at the factory. Confirm all O-rings are in place and the joint is glued. If not, see the instructions below.



**FIGURE "M"**

**O-ring installation and joint gluing (if required):**

**Engine block seal**

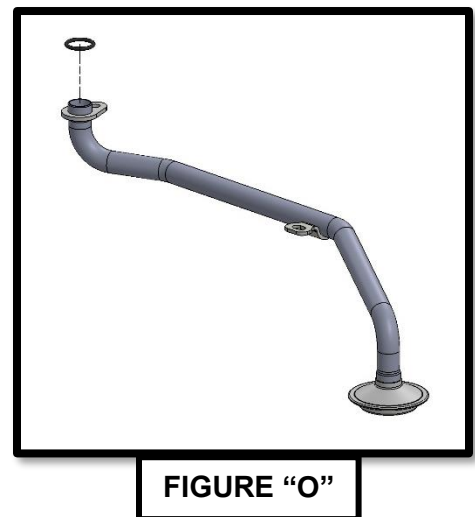
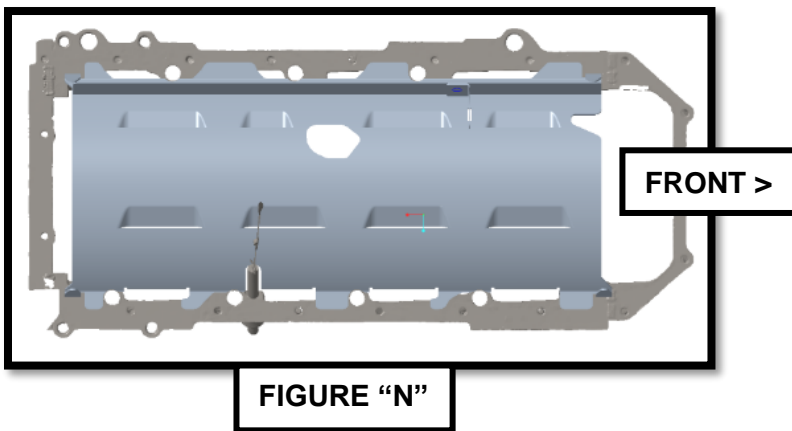
**NOTE:** The supplied O-ring cord will need to be cut to length and glued together.

1. Insert the O-ring cord into the groove on the pan flange. Push straight down when inserting trying not to stretch out the O-ring's length.
2. With the free ends overlapped, mark the position of the cut to be made across both O-ring ends.
3. Carefully remove and lay the O-ring on a flat surface with the ends overlapped and the marks aligned as they were when the marks were made.
4. With a sharp razor blade cut through both ends of the O-ring at the mark simultaneously.
5. With a drop of super glue (Cyanoacrylate), bond the ends of the O-ring together. The glued joint should be smooth, not offset or kinked.
6. To ensure sealing at the glued joint, apply a thin film of silicone sealer around the O-ring at the glued joint, allowing the silicone to partially cure before installation of the O-ring in the groove.
7. Reinstall the O-ring to the groove. Again pushing straight down when inserting, trying not to stretch out the O-ring's length.

**Tray notch fillers**

Cut nine 3/4" (18mm) pieces of the remaining O-ring cord and inset into the groove slots as shown above (**Figure M**). Location in the groove is not critical.

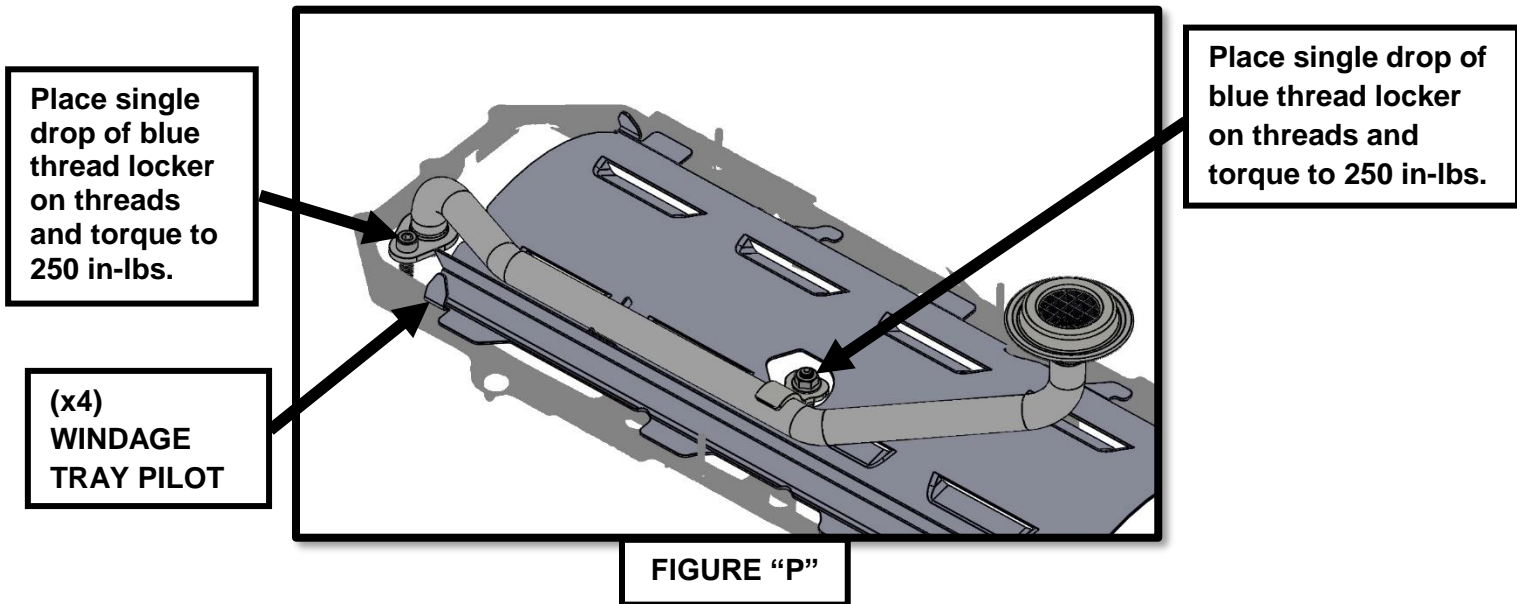
7. Place supplied HOLLEY windage tray on engine block oil pan mating flange. See **FIGURE "N"** for correct location & orientation.



8. Lubricate supplied O-ring with engine oil and install on supplied pickup tube as shown in **FIGURE "O"**.

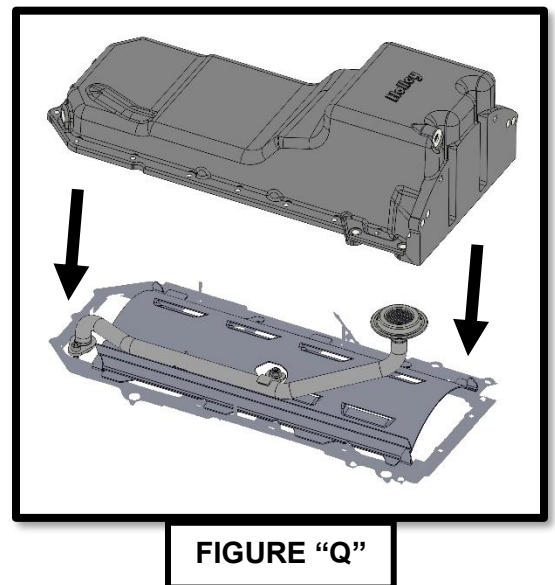
**\*WARNING\*** Make sure to use supplied O-ring. Re-using original O-ring from OEM pickup tube could result in loss of oil pressure and engine failure.

Install the new pickup tube assembly, ensuring that the tube is pushed completely into the oil pump before tightening the bolt. Do not allow the bolt to pull the tube into the pump. Follow instructions shown in **FIGURE "P"** to complete installation of pickup tube.



**NOTE:** Before installing the oil pan, confirm the windage tray is free to float between the pickup and engine block.

9. Take assembled pan and position it onto the engine flange. Pan should locate to windage tray pilots (x4) (**SEE FIGURE "Q"**). Pilot tabs on the windage tray should fully locate the pan to tray but take time to confirm the pan fully mates to engine block all the way around. If there is an inconsistent gap, inspect, and confirm that the windage tray is not caught between the engine block and the oil pan.
10. Install oil pan bolts, making sure bolts thread in easily before starting the bolt tightening process.



11. Before tightening bolts, temporarily install the dipstick and tube. Confirm the dipstick slides fully into and out of the tube with reasonable effort. If it does not, adjusting the angle of the deflector plate may help. Remember, the deflector should not be installed if using a Holley dipstick.



12. Tighten fasteners to 105 in. lbs. in the sequence below. **DO NOT OVERTIGHTEN THE PAN BOLTS!**

Torque bolts in the sequence shown  
in FIGURE "R" to 105 in. lbs.

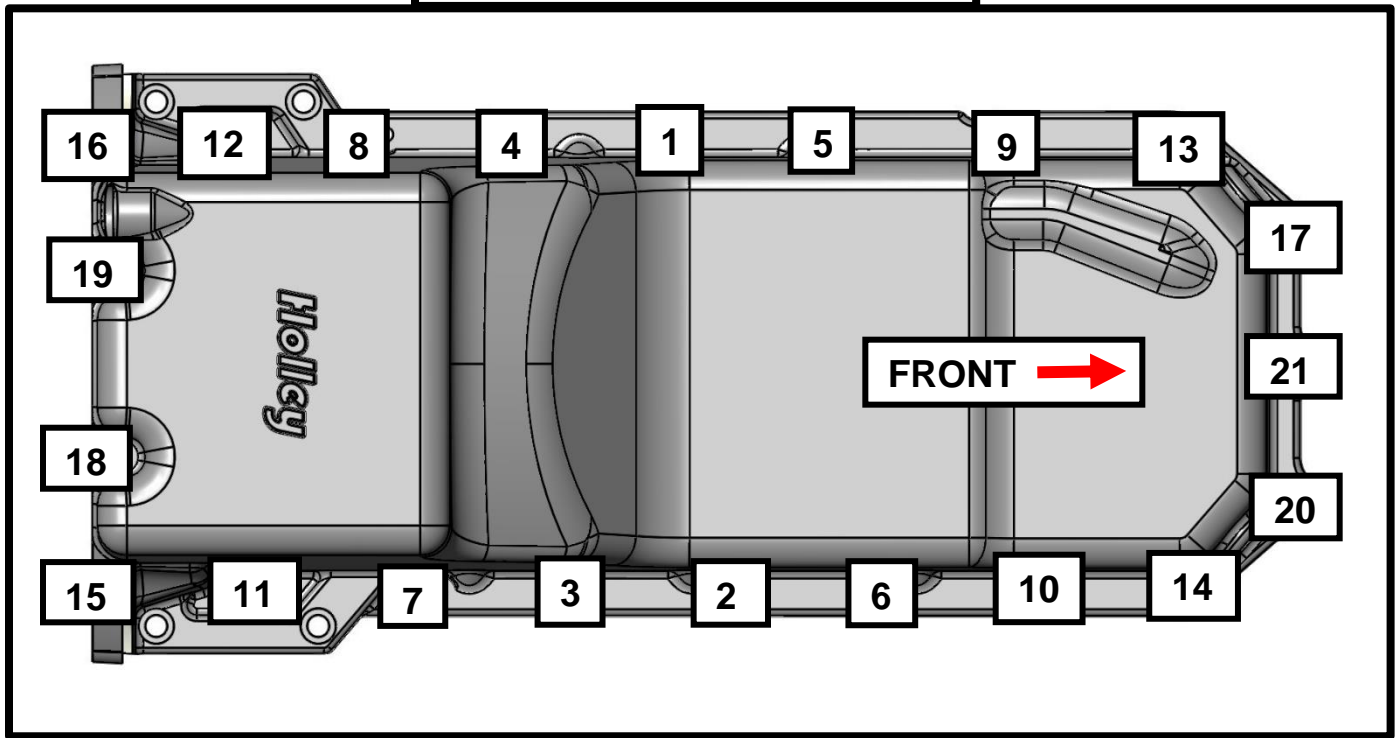


FIGURE "R"

- 13. Install the supplied oil pan drain plug and tighten to 18 ft./lbs (shown in **FIGURE "S"**).
- 14. Install the dipstick tube fully to the engine.
- 15. Install the dipstick.
- 16. Re-Install any accessories previously removed during the oil pan installation. Make sure all connections are secure.



FIGURE "S"

- 17. Fill engine with oil and check proper fill level via dipstick.
- 18. Start the engine and bring up to operating temperature. Check for leaks. Turn engine off and allow to cool.
- 19. Re-check oil level.
- 20. Give vehicle a test drive checking carefully for any new noises or leaks. After several days of driving, check connections and re-tighten all bolts.

Technical Support: **1-866-464-6553** or **1-270-781-9741**.  
For online help, please go to **[www.holley.com](http://www.holley.com)**.

© 2021 HOLLEY. All rights reserved. Tous Droits Réservés.

**199R12301**  
**Revision Date: 12-16-21**