



COOLING FAN RELAY KIT P/N 534-134

INTRODUCTION

Holley Performance Products cannot and will not be responsible for any alleged or actual engine or other damage, or other conditions resulting from misapplication of the products described herein. However, it is our intent to provide the best possible products for our customer; products that perform properly and satisfy your expectations. Should you need information or parts assistance, please contact our Technical Service Department at 1-270-781-9741, Monday through Friday, 7 a.m. to 5 p.m. CST. Please have the part number of the product you purchased on hand when you call.

The cooling fan relay kit (534-134) is designed to provide the power necessary to run a typical 12VDC-cooling fan. The Commander 950 controls the relay via the DARK GREEN / WHITE wire. This turns on the relay to supply power to the fan through the YELLOW / BLUE wire.

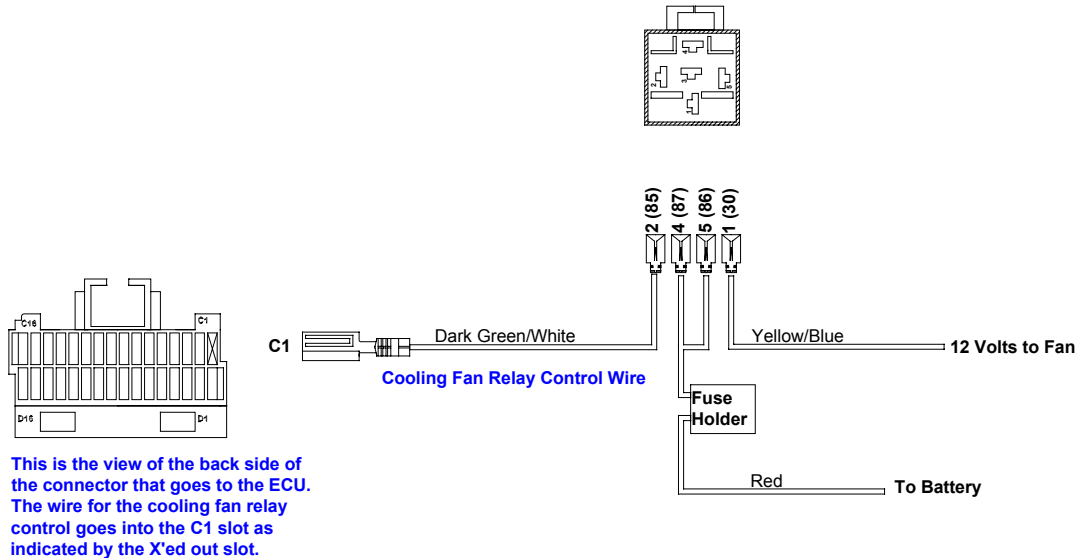

INSTALLATION

1. Remove the plastic retainer that is inserted into the rear of the C row of the C/D connector. This is the connector that has 16 locations as illustrated above.
2. Insert the terminal connected to the DARK GREEN / WHITE wire in the C1 location as indicated in the figure above.

Note: There should be a very faint click as the pin is inserted. Test that the terminal did seat all the way by slightly pulling on the wire to see if it will come out. DO NOT PULL HARD, you can damage the terminal and/or break the wire.

2. Insert the retainer back into the C row, until it snaps into place. This will assure that the pins will not come out later.
3. Connect the RED wire to a 12VDC source. It is preferred that this wire be connected directly to the battery.
4. Connect the YELLOW / BLUE wire to the positive lead of the fan.
5. Connect the negative lead of the fan to a good ground connection.