

# 74410101

## 64-67 GM A-BODY COILOVER KIT (OEM DIFF)



Thank you for your purchase from our new line of GM parts.  
Please call us at (877) 4NO - ROLL if you have any questions  
regarding the service or installation of your Hotchkis products.

Notes:

The Hotchkis coilover system is intended to be installed on a vehicle equipped Hotchkis control arms. If you do not have Hotchkis lower control arms, you will need to purchase an 1104 lower a-arm kit separately.

Before You Start:

This installation will involve cutting, drilling and welding. It is imperative that this kit is installed by a professional installation facility. Once installed the vehicle ride height and wheel alignment will need to be adjusted.

## Front Installation

### 1. Raise Vehicle

Raise the vehicle a lift, floor jack, etc.



### 2. Remove Lower A-Arm

This instruction manual will proceed with the assumption that the customer has the original style Hotchkis lower A-arms Version 1 (P/N# 1104). If you have 1104 version 2 arms then you are good and only need to enlarge (2) holes. If you have already installed the 1104 version 2 Hotchkis a-arms with pre-cut coilover mount, then A-arm removal is not necessary. However, you will still need to remove the shock, spring, and shock mount adapter to install the coilovers.

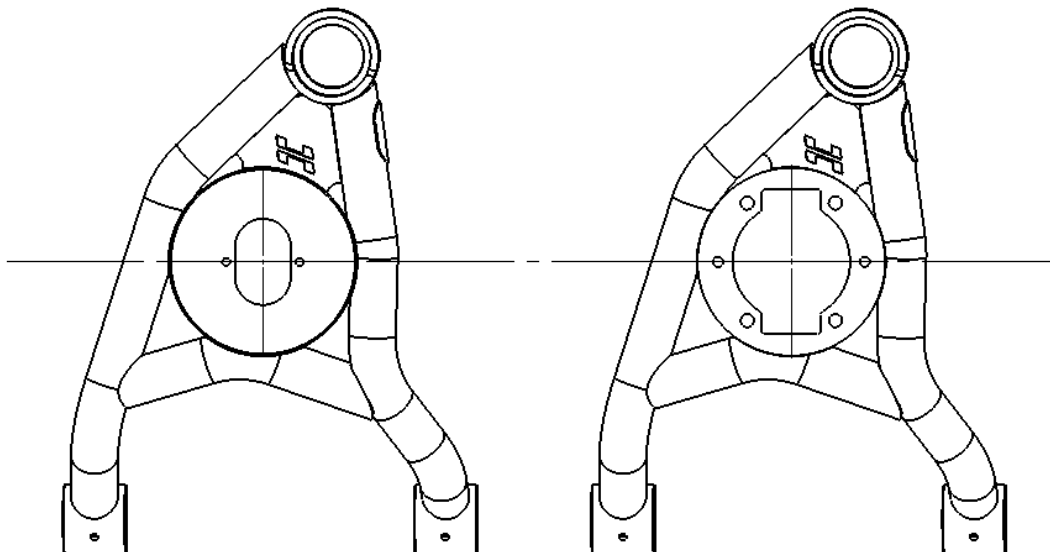

Version 1

Version 2

Raise the front end and remove the wheels. Remove the front shocks.

Remove the lower ball joint cotter pin and loosen (not remove) the castle nut with about an 1/8" of gap. Hit the spindle mount near the ball joint stud carrier with a hammer to break loose the ball joint stud from the spindle. Next, support the lower a-arm with a jack and remove the ball joint castle nut. Lower the jack slowly and relieve the tension in the front spring. Remove the front spring. Unbolt the inner pivot bolts on the A-arm and remove the a-arm from the vehicle.

### 3. Modify Lower A-arm for Coilover Mounting

The coilover access hole is needed to allow the coilover assembly to pass through the lower arm and mount up. The benefit of this type of mounting allows for the user to easily remove the entire coilover assembly from the vehicle without undoing ball joints, etc. Simply unbolt the top and bottom mount and the coilover drops out of the car.

The first step is to cut the center circular hole with a 3-3/4" hole saw.

This kit includes a hole saw guide tool that mounts to the existing shock holes. This guide tool essentially gives you a 1/4" centering hole for your hole saw to spin about.

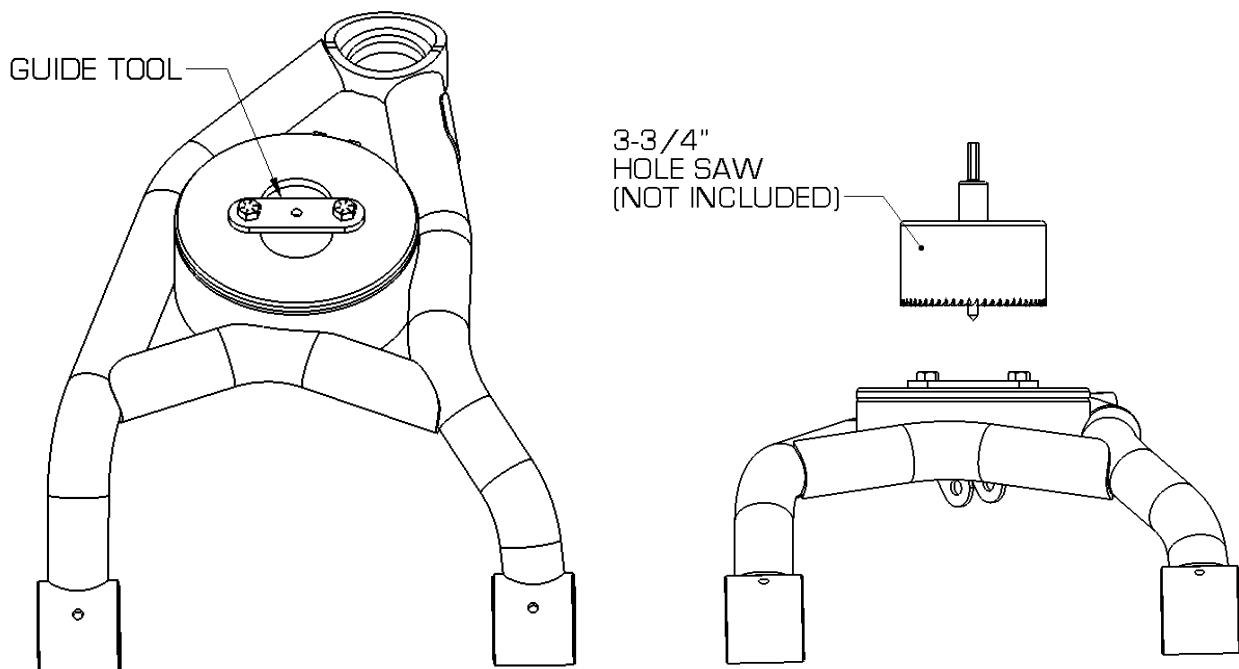

Use the upper retainer plate as a template for the remaining cut out shape. Mark the arm to cut out the square sections. Note the clocking orientation of the cut out shape.

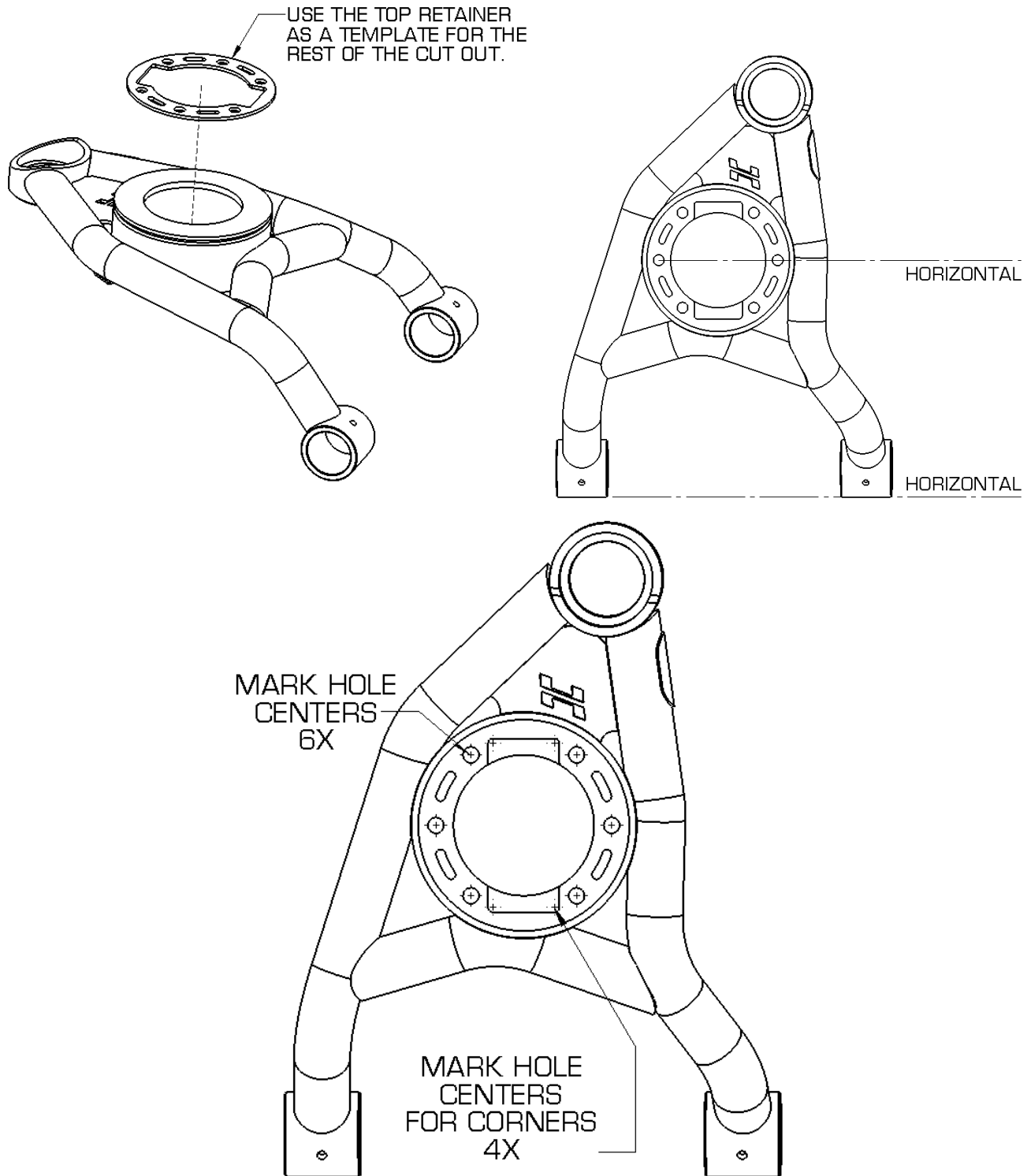

Use a 1/4" drill bit on the corners of the square cut outs.

Use the upper retainer plate again to mark the location of the (6) mounting holes. Use a 13/32" drill bit to drill out the holes.

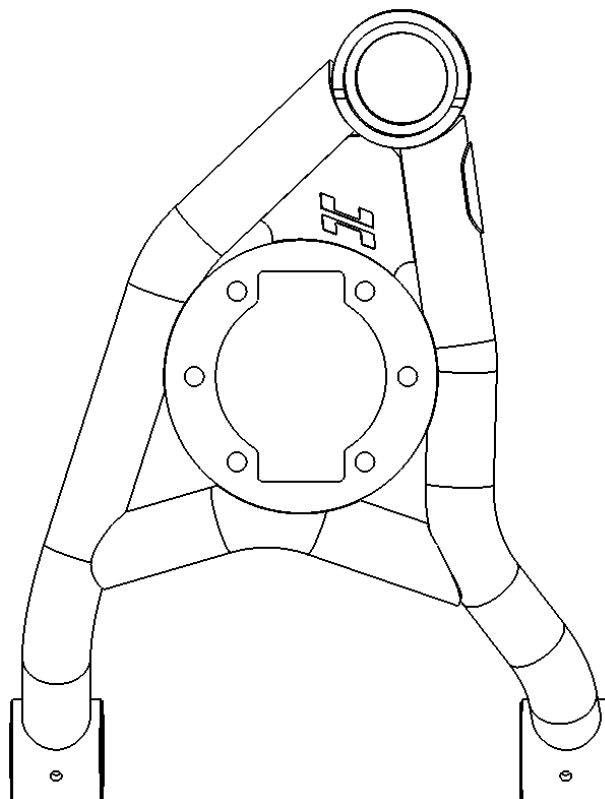
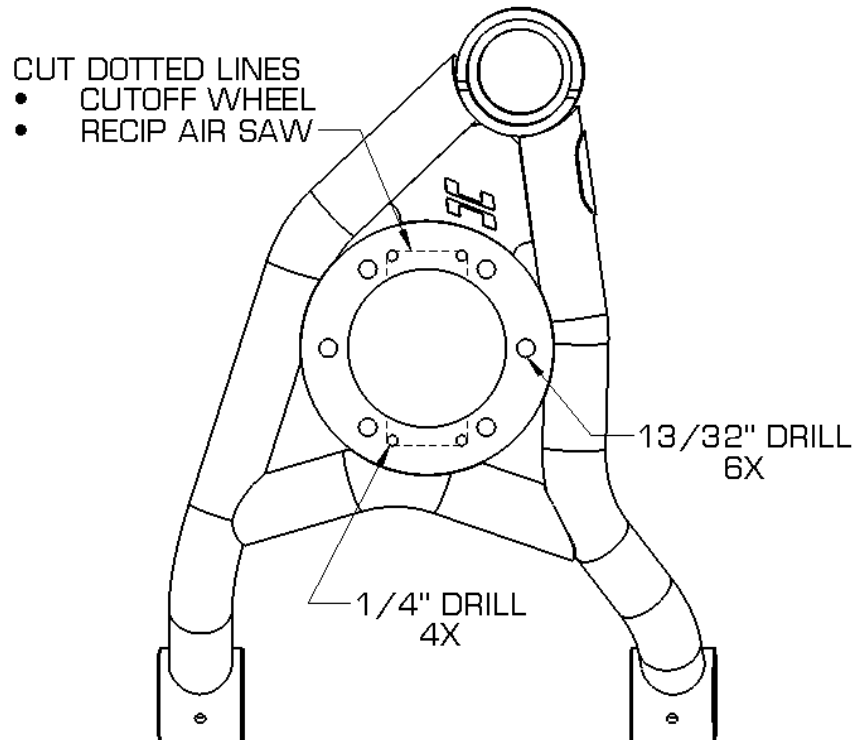

Use a cut off wheel or an air reciprocating saw for the straight cuts.

For customers with the version 2 arms, all you need to do is enlarge the (2) center mounting holes with a 13/32" drill bit.

Sand down any rough edges. Clean and paint the exposed edges with gloss black paint.

#### 4. Clearance the Upper Spring Pocket

Located in the frame, inside the upper spring pocket, you will notice the centering tabs that normally keep the spring in place. These tabs will need to be cut or ground down to allow for clearance for the new coilover assembly. If you leave these tabs, there is a good chance of damaging the coilover top spring hat and the damper itself.

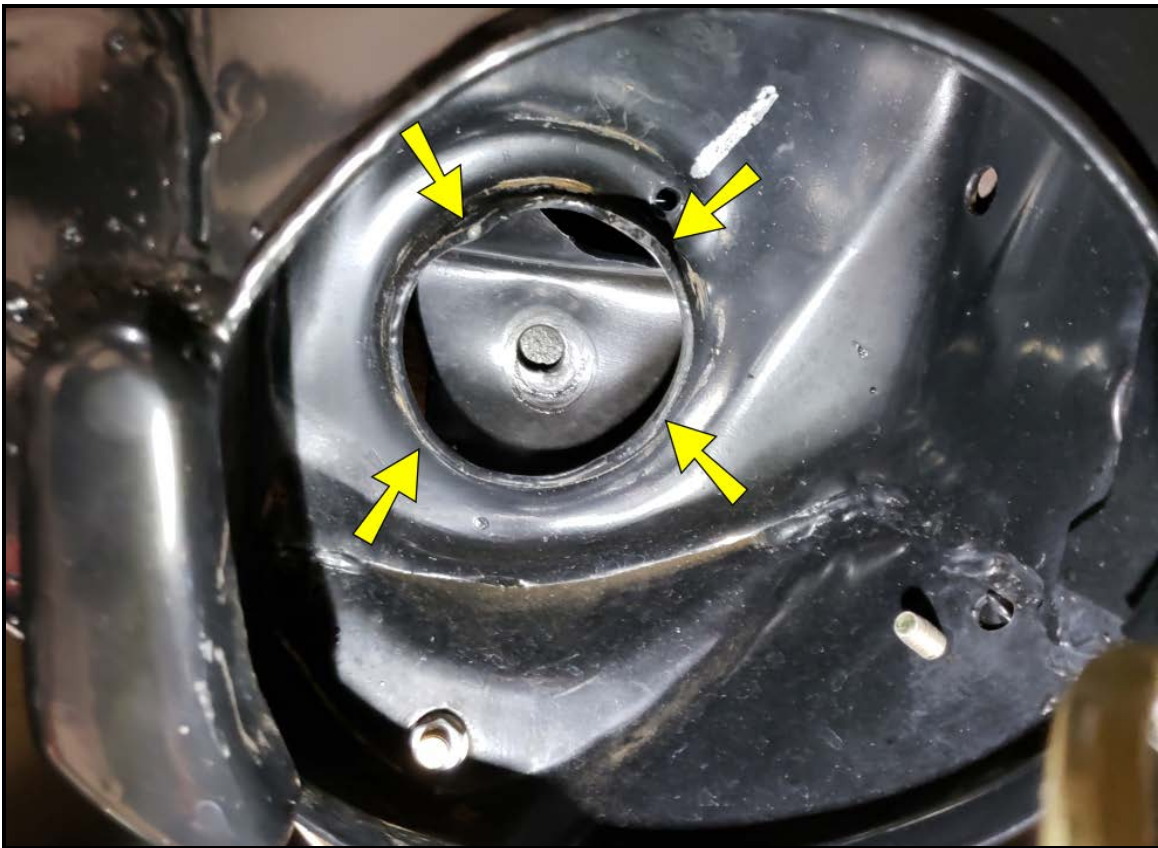

### 5. Drill out Upper Hole Mount

Next we will need to enlarge the upper shock hole to 3/4". Use a 3/4" drill bit and drill out this hole. Make sure to deburr any sharp edges.



### 6. Reinstall Lower A-arm

With the arms & frame modified, reinstall the lower a-arm in the same manner as removal. Don't worry about the coilover assembly yet. It will be installed after the lower arm is back in.

### 7. Install Lower Mount on Coilover

Before we install the coilover on the vehicle, we will install the lower mount onto the shock body. Use the 1/2" fasteners from the hardware pack 17132. When installing the bolt into the mount, it helps to place the washers up against the clevis first. Putting the washer on the bolt might not allow the bolt & washer combo to be installed due to the dropped down nature of the clevis.

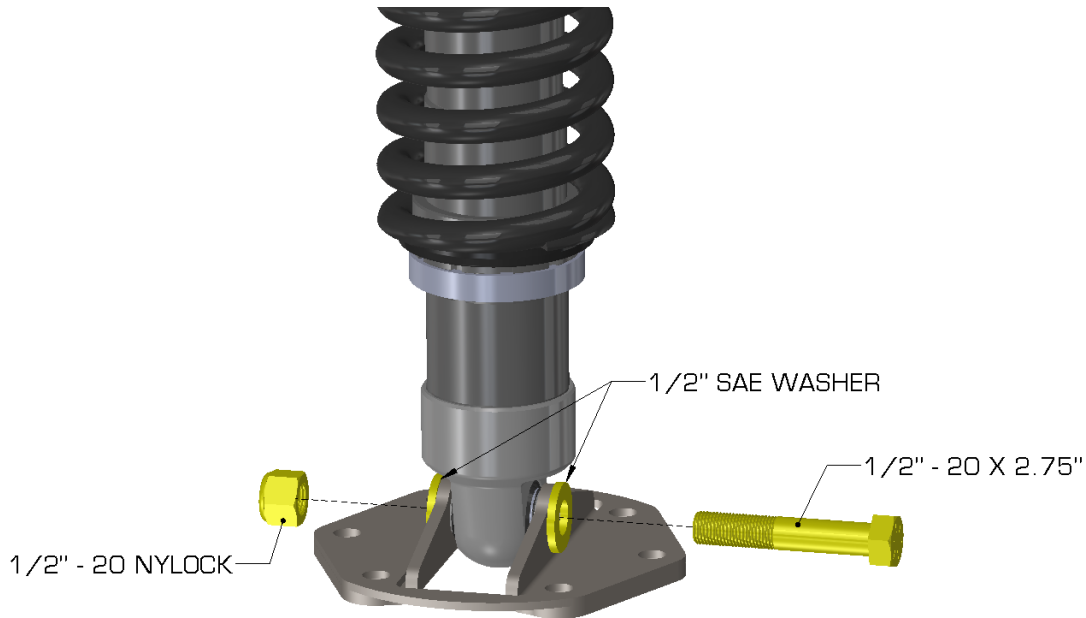

### 8. Install Coilover

First, place the retainer plate on the inside of the a-arm bucket.

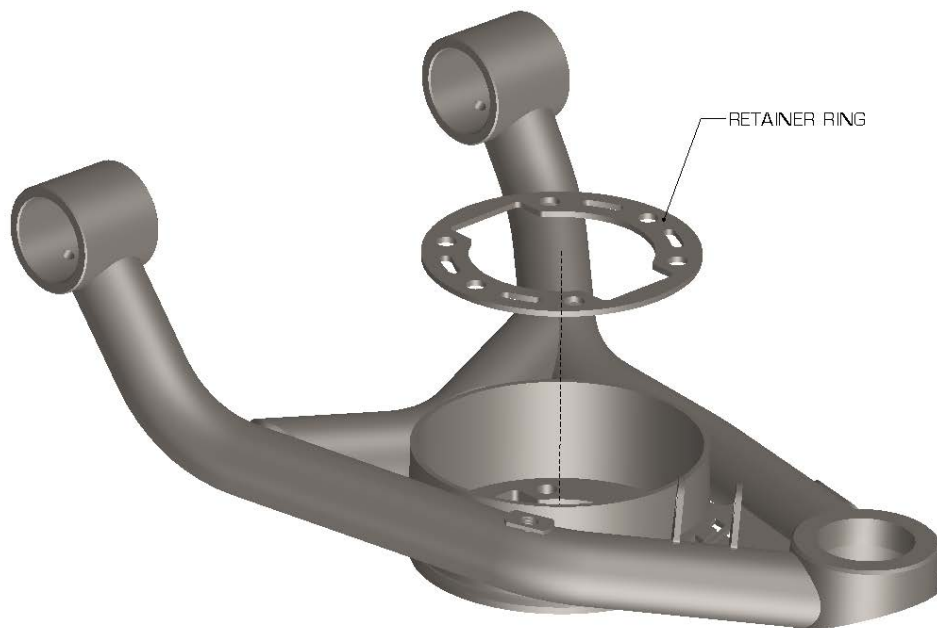



You will need to remove the knob adjuster and indicator base. For easy reinstallation, set the coilover to setting 1 before disassembly. This will allow you to reinstall knowing how to clock the indicator base. The red knob and hex rod should pop out by pulling up. Use a 1/16" allen wrench to loosen the indicator base set screw.

Undo the top shaft lock nut and remove the washer plate and rubber bushing. Leave the harder Delrin bushing on the shaft.

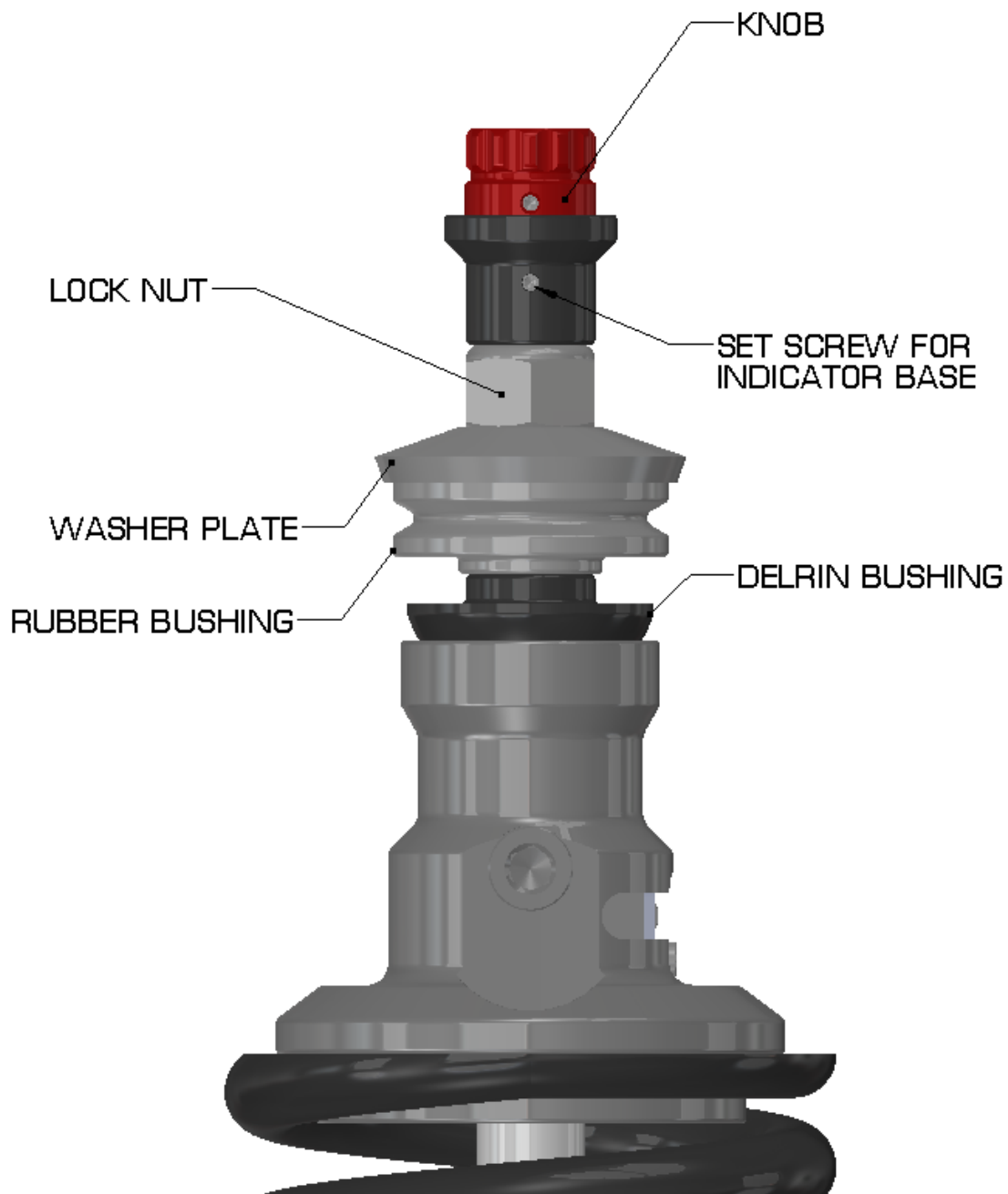

Insert the coilover thru the access hole in the lower a-arm. Guide the upper mount up to the 3/4" shock hole. You may need to adjust the suspension assembly up/down travel to allow this.

If you have the electronic versions, you will need to feed the pigtail connector through the open gaps between the sheet metal mounts on the frame.



**\*SPECIAL NOTE\*** Make sure the Delrin bushing's centering boss is perfectly centered in the 3/4" upper hole. It is very easy to misalign the bushing when fastening the top nut

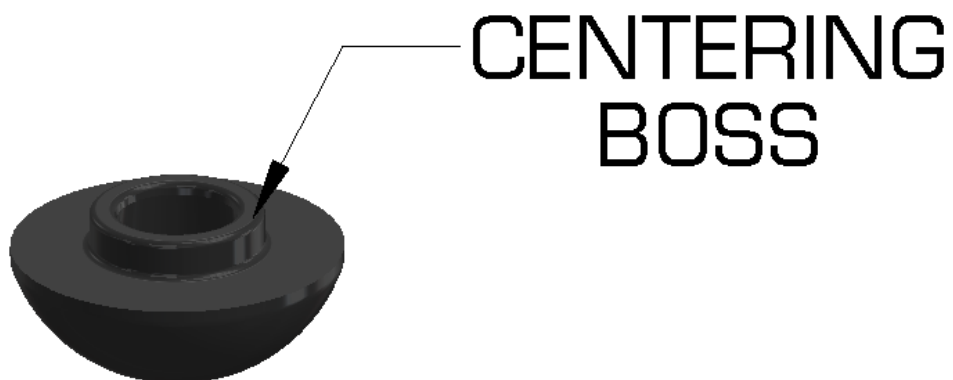



Install the rubber bushing, washer plate, and lock nut onto the shaft thread. Tighten lock nut until the rubber bushing begins to bulge. Do not over tighten.

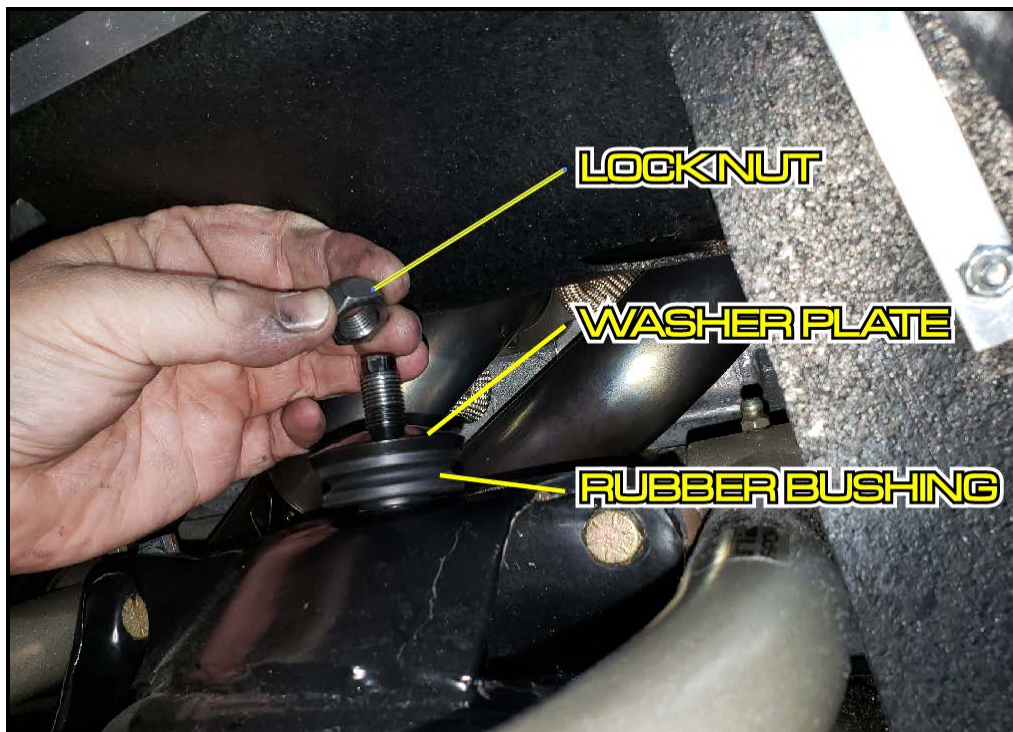

Reinstall the adjuster and indicator base. Clock the indicator base and knob so the setting is set to 1 since it was set to this during removal. If you want to change the clocking of the indicator, you can rotate and set it in 60° increments since it locks onto a hex. Once the indicator is clocked to your liking, recheck the red knob and make sure it is rotated all the way counter clockwise. Loosen the set screw on the red knob and rotate it until the pointer is aimed at "1". Tighten the set screw and your done.

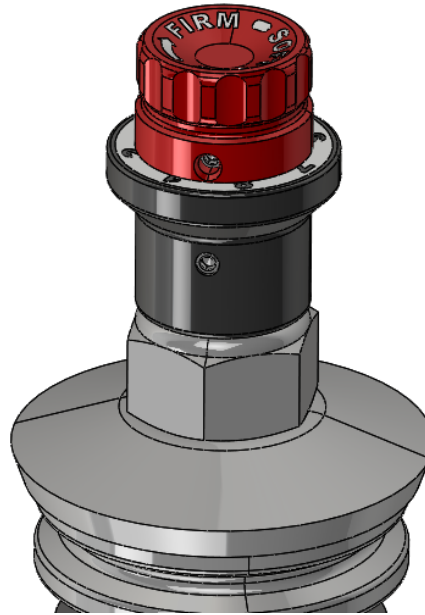

Line up the retainer plate and the lower mount so the (6) mounting bolt holes match. Use the 3/8" fasteners from hardware pack (#17132). Assemble and tighten the 3/8" hardware as shown below.

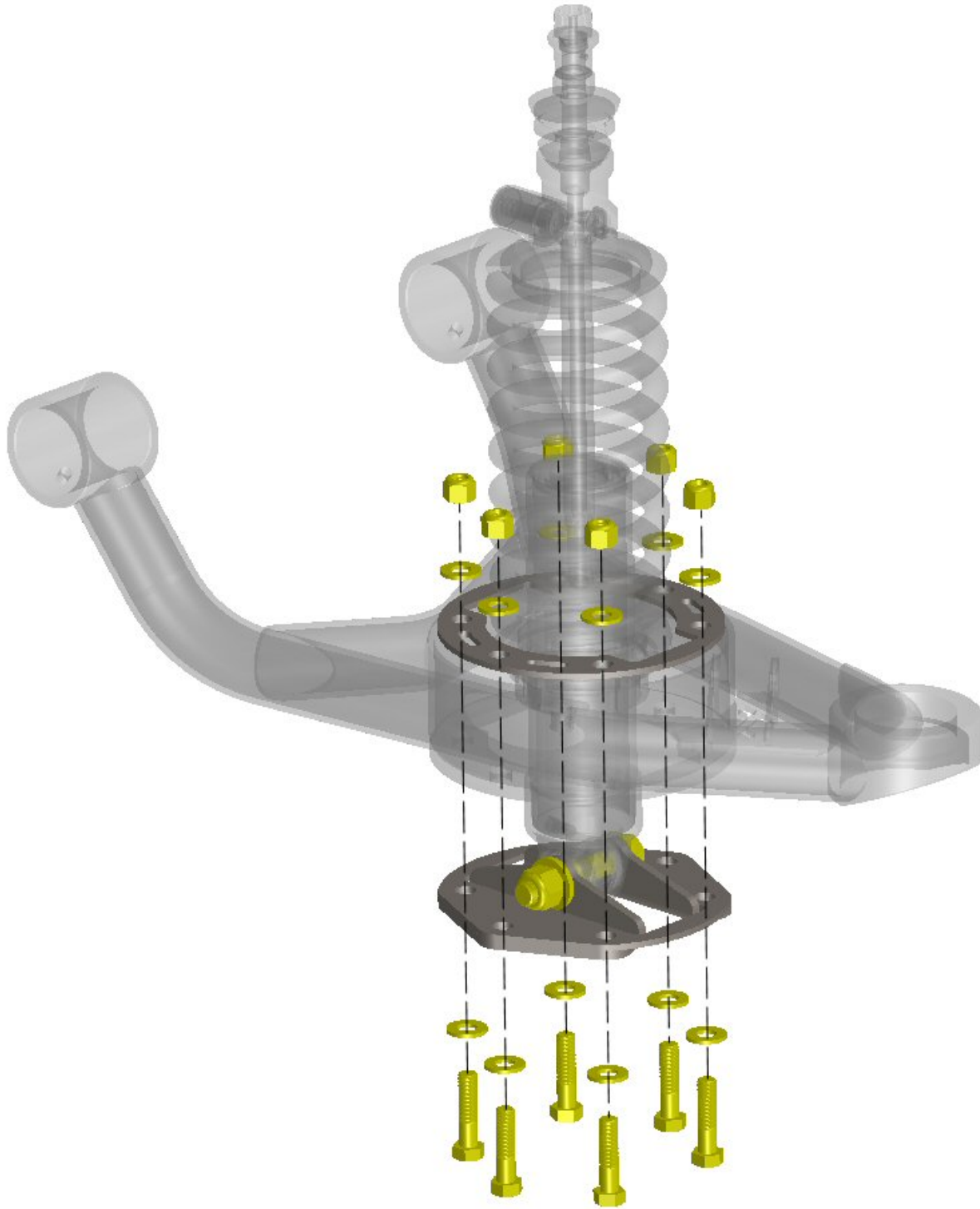

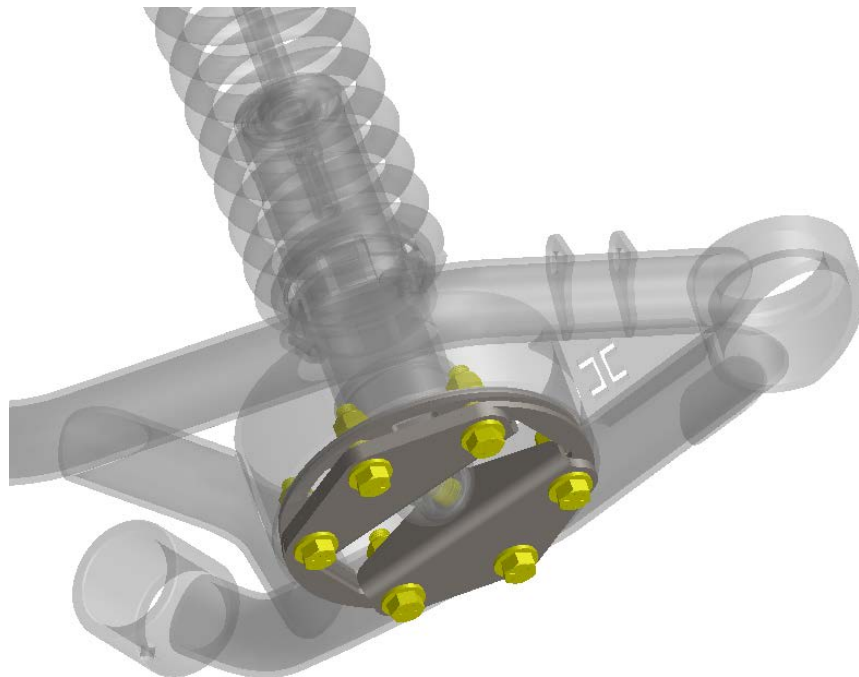
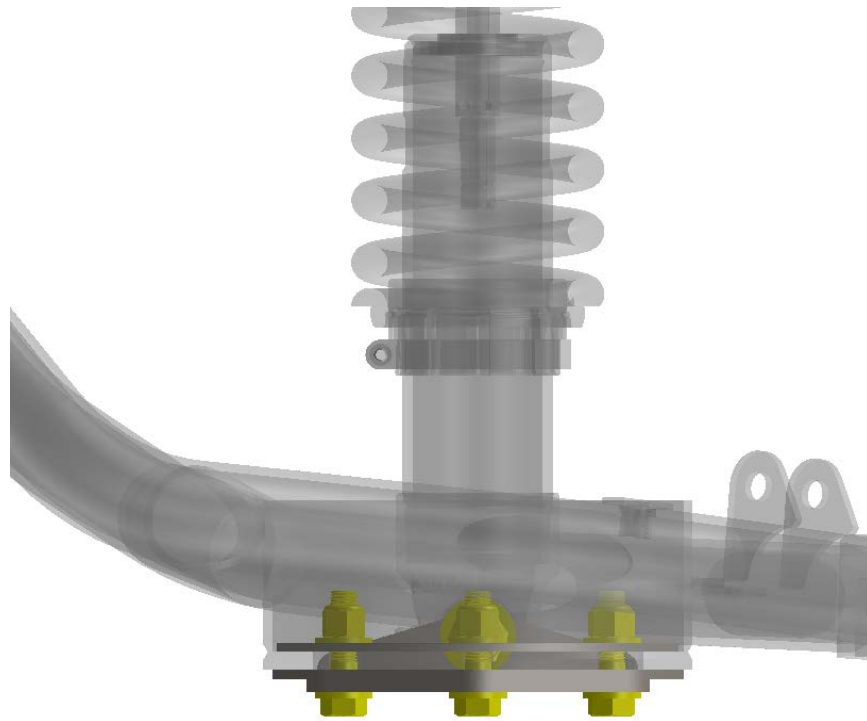



### 9. Adjust Ride Height

If desired, you can adjust the ride height of each coilover by using the provided spanner wrench.

Follow the procedure to adjust height:

- 1) Measure ride height from center of hub to fender. Determine what direction of height adjustment is needed. Follow a typical 2:1 ratio for height change. For every inch of coilover height change, equals to 2 times in wheel to fender height.
- 2) Raise the front end of the vehicle until the weight is off of the coilover.

3) Use an 5/32" Allen wrench on the clamp screw to release the perch adjuster.

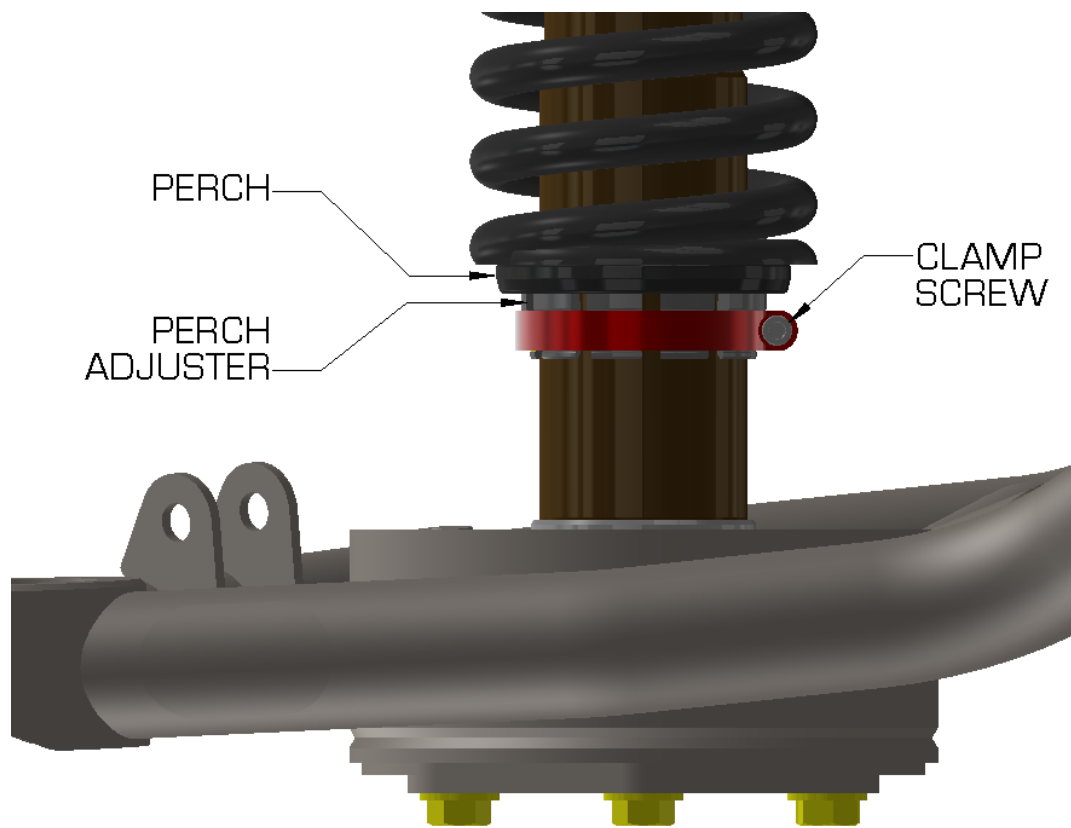

4) If there is no preload on the spring you should be able to spin the perch adjuster by hand. If there is preload, you can use the provided spanner wrench to adjust the height.

5) Repeat steps 1 thru 4 in reverse. Roll the car back and forth to remove any scrub and remeasure the ride height.

Repeat this process until you have reached your desired ride height.



## Rear Installation

### 1. Raise Vehicle

Raise the vehicle a lift, floor jack, etc.

### 2. Remove Rear Shocks

Remove the rear shocks by unbolting the lower stud and (2) upper bolts/nuts per shock.

### 3. Mock Up and Prep Upper Shock Mounts

Chose a side to work on and pick up the corresponding upper shock mount.

For mock up purposes, hold up the upper mount so the bracket holes match the original shock holes. Mark on the frame where the gusset walls meet the frame. This area will need to be sanded to bare metal for welding.

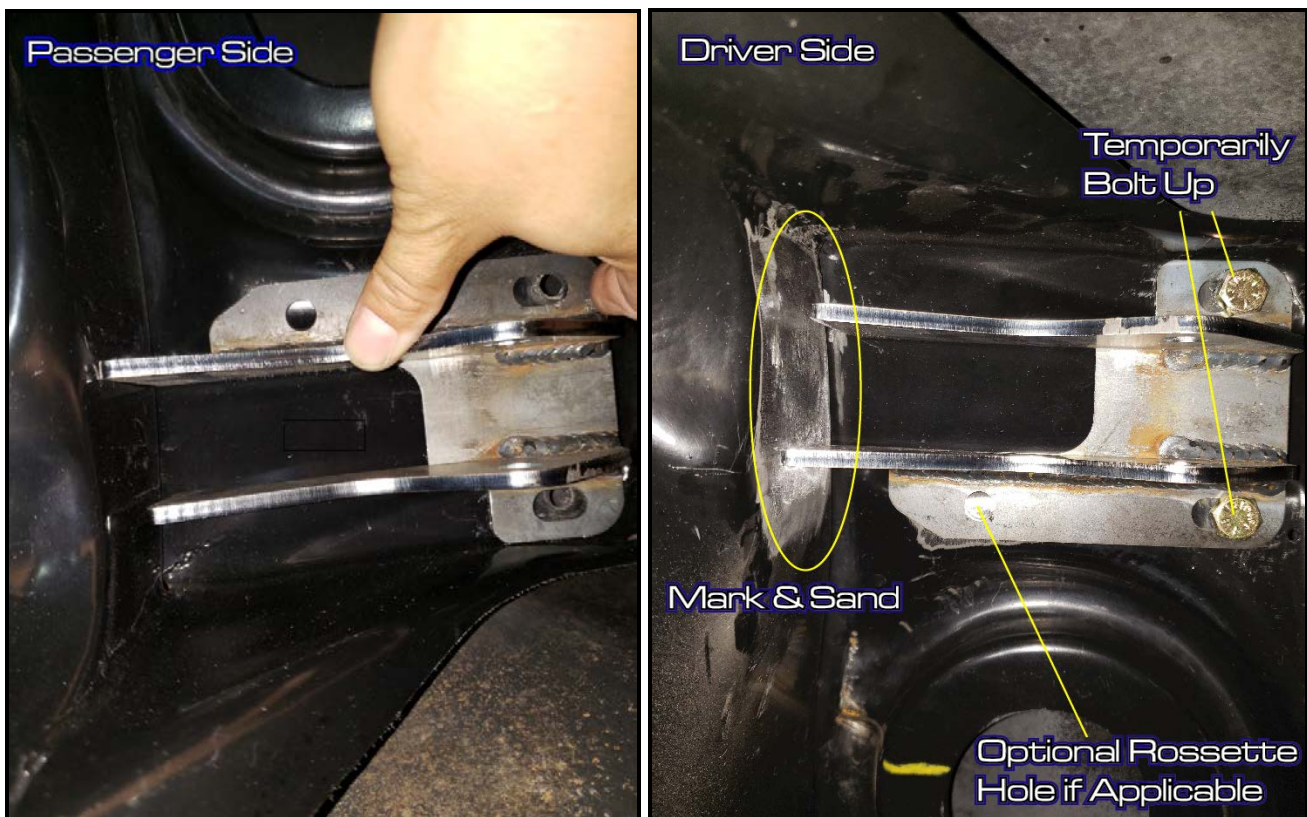

Also sand the gusset wall edges on the Hotchkis brackets. About 3/4" in from the edge should be enough sanding area for the weld. There is an optional rosette hole in the bracket if your frame mates flush with it. If desired, you can sand the powder coat off the hole area for welding as well.

**Sand to bare metal**

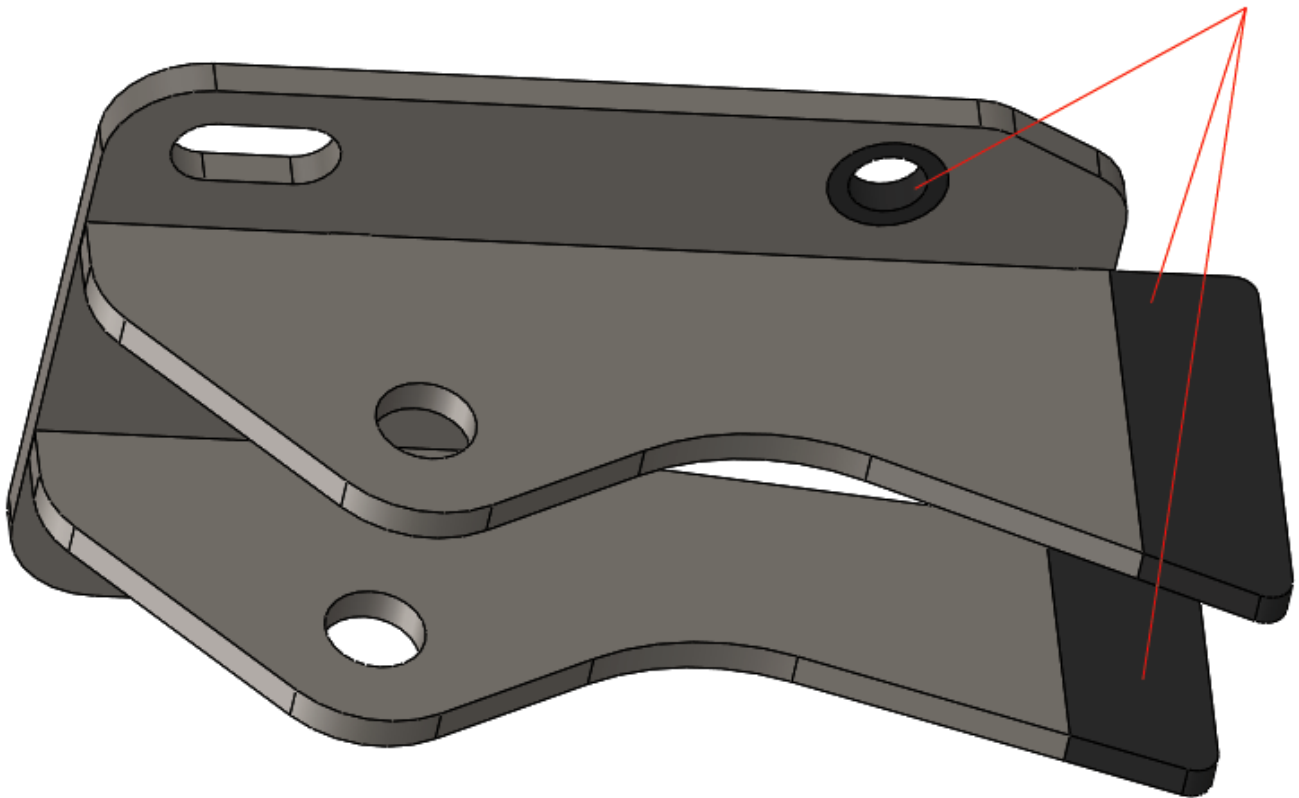

#### 4. Weld Upper Shock Mounts to Frame

Use some spare 3/8" hardware to temporary bolt up the bracket to the frame. Try to position the bracket so the gusset walls are up against or as close to the frame as possible. MIG weld the gusset edges to the frame as shown.

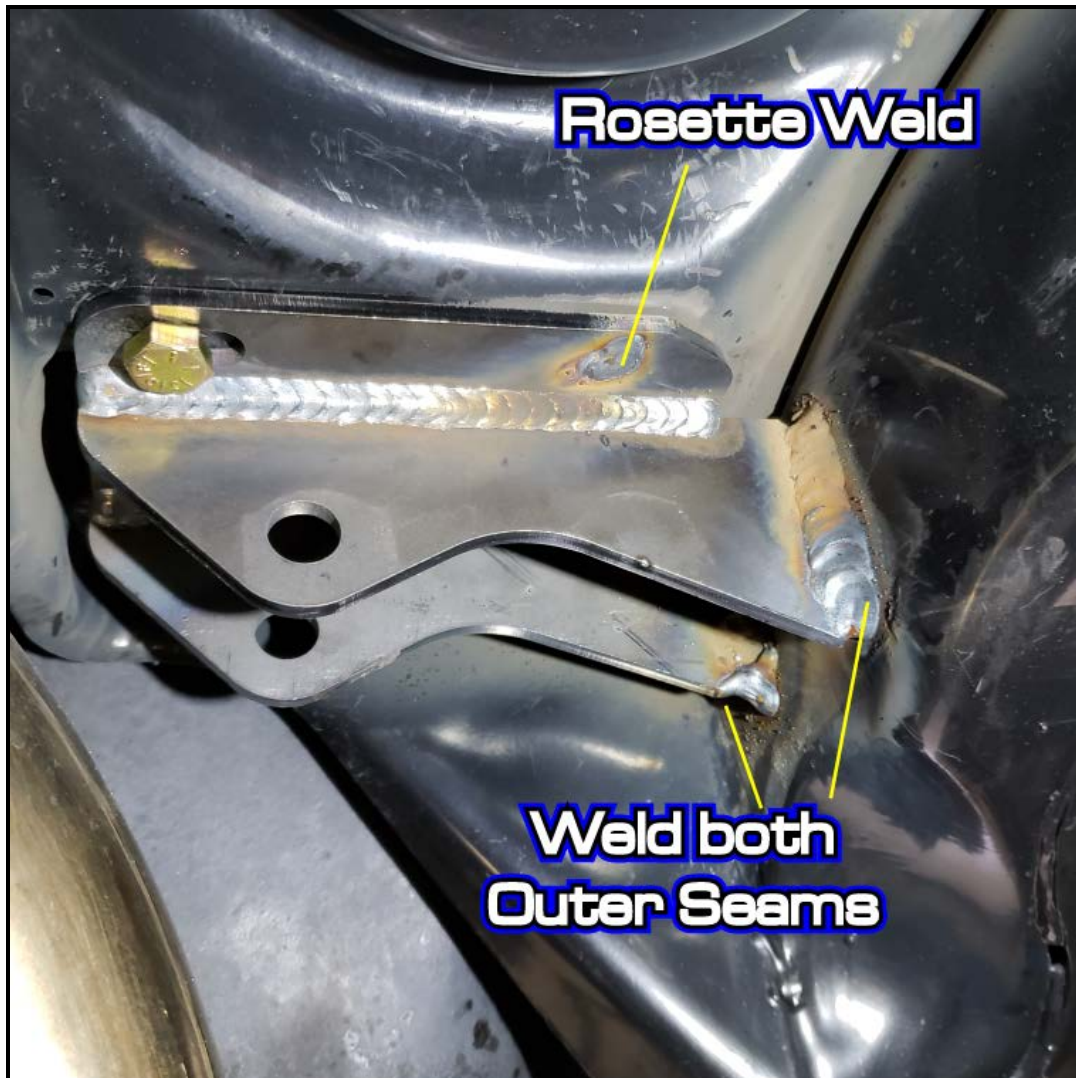

Rosette weld the hole if desired.

Replace the temporary 3/8" hardware with the 3/8" hardware included in bag (#17134).

Spray paint any exposed metal areas.

### 5. Install Hotchkis Lower Mount

The Hotchkis lower coilover mount utilizes the rear lower trailing arm mounting point. Undo the rear lower trailing arm bolt. Slide the lower bracket onto the rear lower trailing arm mount. Install the included 1/2"-20 x 4.25" bolt from hw kit (#17135) to hold the bracket in place. You do not need to install the nut yet.

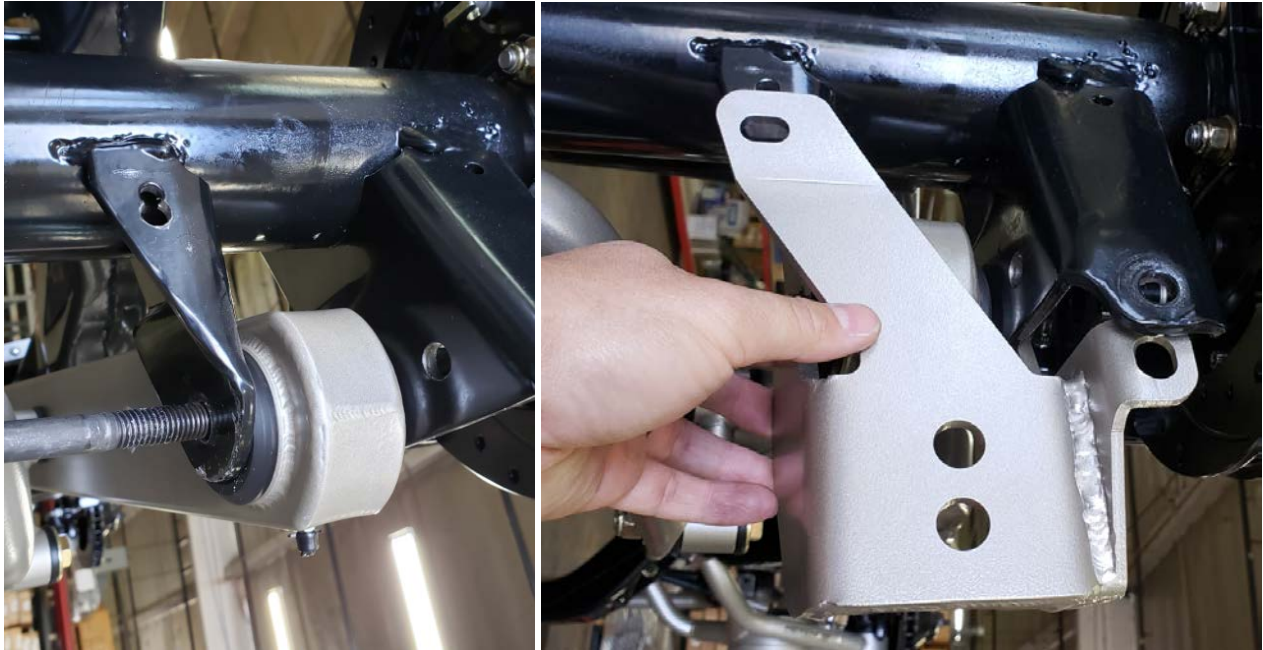

In some cases, you may need to clearance the bracket on the axle to allow the lower mount to fully rotate up.



Mark the center of the slot to drill a 3/8" hole. You can remove the bracket if it gets in the way of drilling.



Reinstall the bracket with the 1/2"-20 x 4.25" hex bolt, washers, and nylock nut. Install the 3/8"-24 x 1.25" button head bolt with no washer on the head side. Use the 5/16 USS washer and 3/8"-24 nylock nut. Keep the nuts loose for now.



The bracket also utilizes the original shock mount hole. In some cases you will need to use spacer(s) in between the axle bracket and the hotchkis bracket. Use the provided spacers to take up the gap. Use the 1/2"-20 x 1.75" bolt to secure this mounting point.

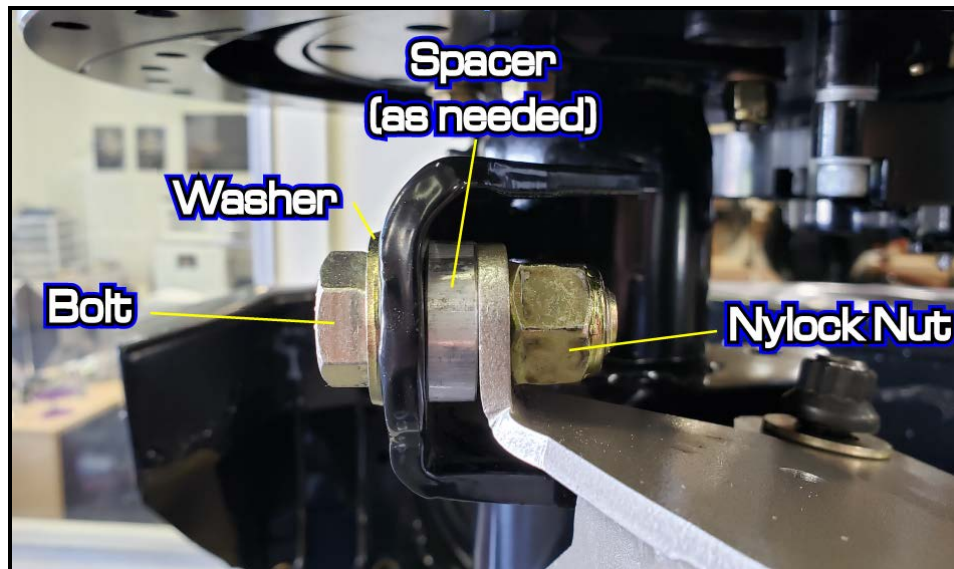

## 6. Install the Coilover

Use the 1/2"-20 x 2.75" bolt, washer and nylock nut to fasten the coilover to the upper mount.

Electronic coilover Note:

If you have electronic coilovers, you will need to mount the body end to the top (red adjuster at the bottom). If your coilover has the tall spacers installed on the body end, you will need to swap them with the short spacers on the shaft end. The top mount only accepts the small short spacers. Non-adjustables can be mounted either way.

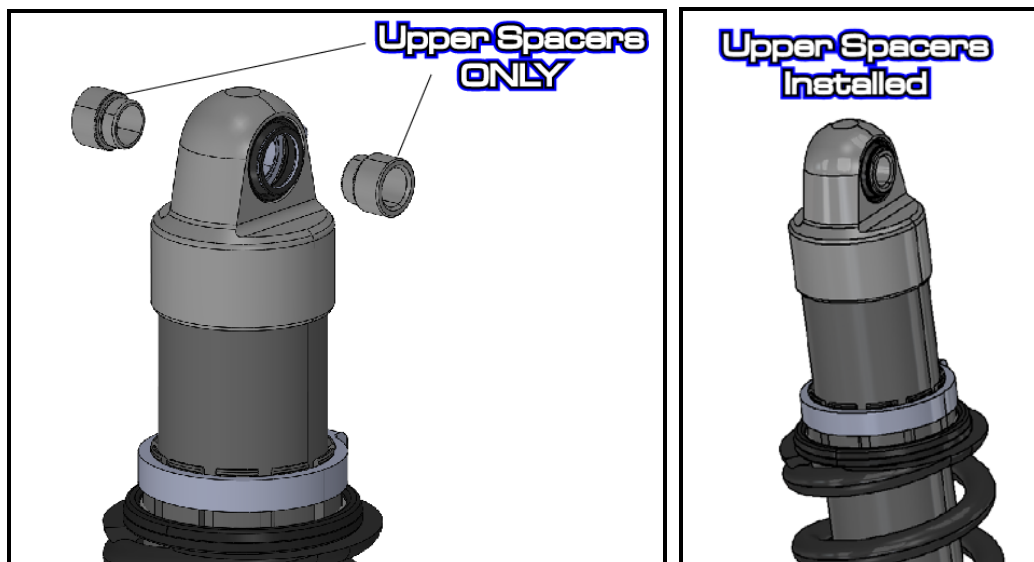

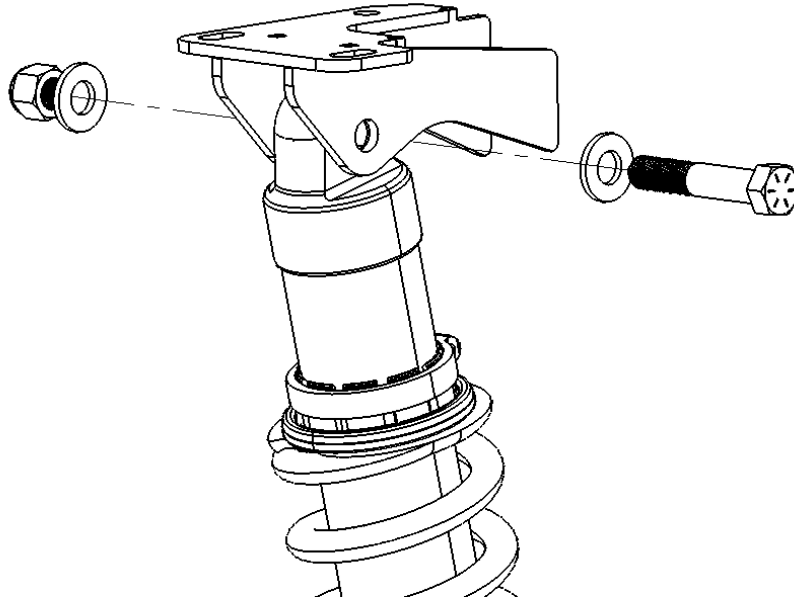

Non-adjustables can be mounted either way.

Grab hw pack (#17137) and install 5/8"-18x5" bolt and the Hotchkis washer plate. Insert the bolt through the bottom hole. From the rear side install the Hotchkis support spacer. Use the 5/8-18x1" socket head bolt and insert it through the top hole of the washer plate. Thread the socket head bolt into the support spacer. Mount the coilover end on the 5/8" bolt. Make sure the tall spacers are installed on the end that is attaching to the 5/8" bolt. The lower mount only accepts the tall spacers. Follow up with the 5/8 SAE washers and 5/8 nylock nut.

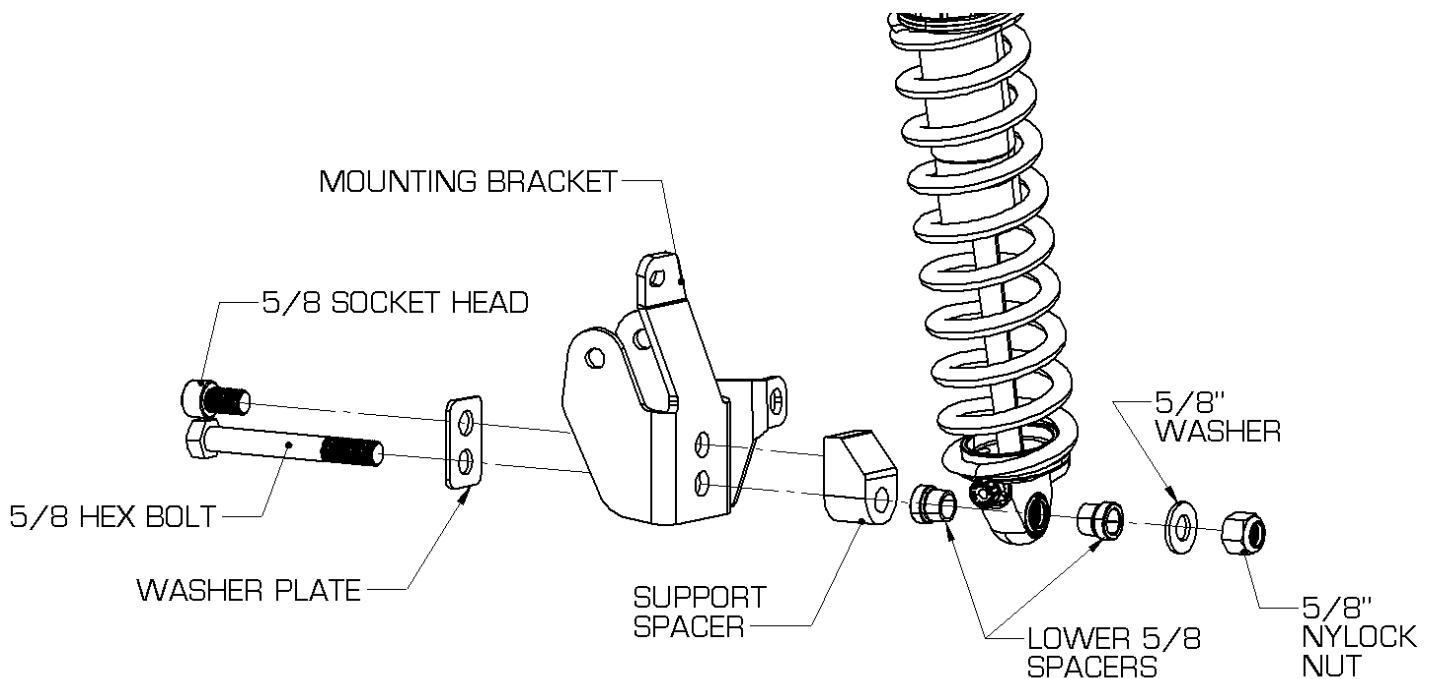





## 7. Install Hotchkis Bumpstop

Replace the rear oem bumpstop with the Hotchkis bumpstops.

## 8. Adjust Ride Height

If desired, you can adjust the ride height of each coilover by using the provided spanner wrench.

Follow the procedure to adjust height:

1) Measure ride height from center of hub to fender. Determine what direction of height adjustment is needed. Follow a 0.875:1 ratio for height change. For every inch of coilover height change, equals to about 0.875" in wheel to fender height.

2) Raise the rear end of the vehicle until the weight is off of the coilover.

3) Use an 5/32" Allen wrench to unlock the body perch.

4) If there is no preload on the spring you should be able to spin the perch by hand. If there is preload, you can use the provided spanner wrench to adjust the height.

5) Repeat steps 1 thru 4 in reverse. Roll the car back and forth to remove any scrub and remeasure the ride height.

Repeat this process until you have reached your desired ride height.



# Terms and Conditions

All information contained herein is subject to change without notice. BUYER'S ACCEPTANCE OF DELIVERY OF THE PRODUCT CONSTITUTES BUYER'S ACCEPTANCE OF THE TERMS HEREIN. ANY ADDITIONAL OR DIFFERENT TERMS PROPOSED BY THE BUYER ARE HEREBY REJECTED IN THEIR ENTIRETY UNLESS EXPRESSLY ASSENTED TO IN WRITING BY SELLER'S AUTHORIZED AGENT.

## TERMS

Prepaid, Visa, MasterCard. Net 30 days from invoice date terms are available after credit approval. Accounts with invoices past due will be placed on "Credit Hold". A finance charge of 1.5% per month will also be applied to all past due invoices, not to exceed the maximum charge permitted by law. Accounts considered paid in full upon Hotchkis Performance Inc.'s receipt of the full invoice amount plus collection fees and expenses incurred, if any. NSF checks, stop payment checks, chargeback's on credit cards, etc. are charged a minimum of \$35 fee. No deduction or credit may be taken for any reason unless a credit memo has been issued by Hotchkis Performance Inc. Any unauthorized deduction will automatically put the account on credit hold. Other product special orders require a 50% down payment and are also non-cancelable and non-returnable.

## DROP SHIPMENTS & REFUSED PACKAGES

Drop shipments are charged a \$30 service charge. A 20% restocking fee and all shipping costs are charged to the ordering party if a package is refused. No international drop shipments.

## RETURNS

Hotchkis Performance Inc. will issue a R.M.A. number for every return. Returns will not be accepted without the R.M.A number. All authorized returns must have the R.M.A number on all cartons and shipping documents. Returned product must be shipped prepaid – collect shipments will be refused. Modified or used products are not eligible for return. Returns can be made within 90 days after invoice date. May be subject to a 20% restocking fee. No returns are accepted after 90 days. Freight charges are not refundable unless the merchandise is defective as determined by Hotchkis Performance Inc. Special orders are not returnable.

## DAMAGED SHIPMENTS / SHORTAGES

All Hotchkis Performance Inc.'s shipments are F.O.B. our factory. Title passes from Hotchkis Performance Inc. to the purchaser at the time of shipment. Carton shortages and damages must be claimed against the carrier at the time of delivery. To expedite processing of claims against the carriers, the customer must note damages on the bill of lading at the time of the delivery, and promptly request and inspection by the carrier or its claims agent. If a shortage is found within the shipment it must be reported to Hotchkis Performance Inc. in writing within five (5) business days of receipt of shipment. Claims should refer to the order number, invoice number, date of invoice, date of shipment, part number, description and carton count.

## PRODUCT SUBSTITUTION / OTHER

Hotchkis Performance Inc. reserves the right to substitute equal or stronger materials of products at its discretion. Hotchkis Performance Inc. reserves the right to change specifications and other information included in this catalog without notice. All information, data and dimension tables in this catalog have been carefully compiled and thoroughly checked. However, no responsibility for errors or omissions can be assumed. Some parts are not legal for sale or use in California on any pollution controlled motor vehicles.

## WARRANTY / DISCLAIMER

Hotchkis Performance Inc. warrants that the products will be free from defect in material and workmanship for three years from date of sale to the original purchaser. Hotchkis Performance Inc. makes no other warranty of any kind, express or implied. Hotchkis Performance Inc. shall have no obligation under the forgoing warranty where the defect is the result of improper or abnormal use, your negligence, vehicle accident, improper or incorrect installation or maintenance, nor when the product has been repaired or altered in any way. Hotchkis Performance Inc.'s liability in the case of defective products subject to the forgoing warranty shall be limited to the repair or replacement, at Hotchkis Performance Inc.'s option, of the defective products. Hotchkis Performance Inc. will be the sole judge of warranty claims.

Consequential or incidental damages are not recoverable under this warranty. Some states do not allow the exclusion or limitation of incidental or consequential damages, so the above limitation or exclusion may not apply to you. This warranty gives you specific legal rights, and you may also have other rights which vary from state to state.

In order to be eligible for service under this warranty, you must return the defective part to Hotchkis Performance Inc. together with R.M.A number issued from Hotchkis Performance Inc. and a copy of your receipt showing purchase within past 3 years. Tag each item with the part number and the specific explanation of defect. We will inspect the part and determine: a) if it is eligible for repair or replacement; and, b) if so, whether to repair or replace it. All returns must be shipped prepaid to:

Hotchkis Performance Inc.  
RMA # \_\_\_\_\_  
8633 Sorensen Ave  
Santa Fe Springs, CA 90670

Hotchkis Performance Inc. will return all products covered under warranty to you by ground freight at Hotchkis Performance Inc.'s expense. Any expedited freight is the responsibility of the customer.

THE BUYER UNDERSTANDS AND EXPRESSLY RECOGNIZES that ALL parts and services sold by Hotchkis Performance Inc. are exposed to many and varied conditions due to the manner in which they are installed and used. BUYER ACKNOWLEDGES that HOTCHKIS PERFORMANCE INC. does not have full knowledge of the intended use of goods, and BUYER WILL DEFEND AND INDEMNIFY HOTCHKIS PERFORMANCE INC. upon demand against all claims, actions, liability, loss and expense (including investigating expense and attorney fees incurred in litigation or because of threatened litigation) for any loss, damage or injury, either to a person or to property, resulting from the direct or indirect use of any Hotchkis Performance Inc. products or inability by the buyer to determine proper use or application of Hotchkis Performance Inc. products. With the exception of the limited liability warranty set forth above. Hotchkis Performance Inc. SHALL NOT BE LIABLE FOR ANY CLAIMS, DEMANDS, INJURIES, DAMAGES, ACTIONS, OR CAUSES OF ACTION WHATSOEVER TO BUYER ARISING OUT OF OR CONNECTED WITH THE USE OF ANY HOTCHKIS PERFORMANCE INC. PRODUCTS

MOTORSPORTS AND SIMILAR ACTIVITIES ARE DANGEROUS; AS SUCH, NO WARRANTY OR REPRESENTATION IS MADE AS TO THE PRODUCT'S ABILITY TO PROTECT THE USER FROM INJURY OR DEATH. THE USER ASSUMES THAT RISK