

Installation Instructions for 10150 Chrome Alternator Case

Tear-Down of Stock Alternator

1. Disconnect the battery negative (-) cable at the battery, then disconnect the positive (+) cable.
2. With the alternator still in position on the engine and the belt in place attempt to loosen the nut that secures the pulley. Do not apply unneeded force to remove the pulley at this time, it can also be removed on the workbench.
3. Scribe a line or mark the sides of the case where the front and rear sections meet in a fashion that will aid you in the reassembly process.
4. Now you can proceed to remove the four #10 fasteners that secure the front and rear case sections together. Carefully pry the sections apart with a screwdriver. **The stator (windings) must stay with the rear section during this step!** With the housings separated remove the brushes.
5. Remove the three #8 nuts that fasten the stator to the rear housing. The stator must be removed by prying evenly from the case. For extra precaution, this is a good time to have friend handy to help secure the housing if you do not have a vise in your garage. **Once the stator is removed, handle it carefully as the wires are delicate to the touch.**
6. Remove the three #8 screws holding the diodes, brush holder and voltage regulator in place. Two of the screws have plastic sleeves for insulating purposes while the third is for a ground. **If the screws are not reassembled in the proper sequence your alternator will not function.**
7. Remove the rectifier bridge assembly by removing the fasteners from the battery and capacitor screw. Remove the terminals and its insulators.
8. If you were not able to remove the pulley on the vehicle, place the rotor in a vise with soft jaws (or use something to protect the rotor from damage). Tighten the vise with minimal force to loosen the nut and remove the pulley. Be careful - this is one of the most delicate components of the alternator.
9. Remove the rotor from the old front section of the case. Install it in the new front section case and reinstall the pulley and nut and secure it in place.

Build-Up of the Chrome Case Alternator

1. Push the springs and brushes back into the holder and fabricate a 1-1/4" long wire (small diameter welding rod is ideal) and insert into the assembly hole. (see Illustration 1)
2. The reassembly of the alternator can begin in the reverse sequence of the tear-down.
3. The new case halves can now be assembled. Use the scribed lines on the old case as your guide. The assembly procedure should need little or no coaxing to go together. The new case bolts can be used to secure the two sections together and torque evenly.
4. Now you can remove the pin from the rear of the housing holding the brushes in place. **One important point is the correct placement of the insulating washers and sleeves - without their use the alternator will not function!**
5. At this point, the alternator should spin freely. If not, loosen the fasteners and tap lightly until it spins easily, then retighten the fasteners.
6. Reinstall the alternator and attach the correct wires to the terminals.
7. Adjust the belt tension so as not to cause bearing failure.
8. The battery cables can now be reinstalled. Double check all your electrical connections before starting the engine. Be sure the alternator is operating properly and correctly charging the battery.

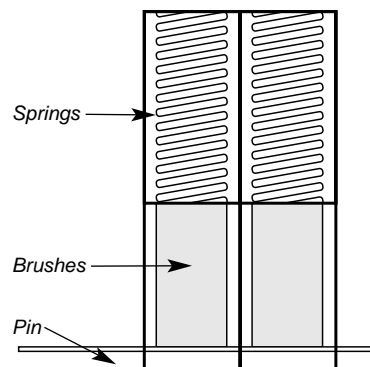

Illustration 1

Installation Instructions for 10151 Chrome Alternator Case

Tear-Down of Stock Alternator

1. Disconnect the battery negative (-) cable at the battery, then disconnect the positive (+) cable.
2. With the alternator still in position on the engine and the belt in place attempt to loosen the nut that secures the pulley. Do not apply unneeded force to remove the pulley at this time, it can also be removed on the workbench.
3. Scribe a line or mark the sides of the case where the front and rear sections meet in a fashion that will aid you in the reassembly process
4. Now you can proceed to remove the four #10 fasteners that secure the front and rear case sections together. Carefully pry the sections apart with a screwdriver. **The stator (windings) must stay with the rear section during this step!** With the housings separated remove the brushes.
5. Remove and clean all components Carefully from the rear case section. It would be helpful to you to make some notes where the parts are located. **Pay close attention to the insulating washers and sleeves - if they are missing or are not in the proper location, the alternator will not function!**
6. If you were not able to remove the pulley on the vehicle, place the rotor in a vise with soft jaws (or use something to protect the rotor from damage). Tighten the vise with minimal force to loosen the nut and remove the pulley. **Be careful - this is one of the most delicate components of the alternator.**
7. Remove the rotor from the old front section of the case. Install it in the new front section case and reinstall the pulley and nut and secure it in place.

Build-Up of the Chrome Case Alternator

1. Push the springs and brushes back into the holder and fabricate a 1-1/4" long wire (small diameter welding rod is ideal) and insert into the assembly hole. (see Illustration 1)
2. The reassembly of the alternator can begin in the reverse sequence of the tear-down. **One important point is the correct placement of the insulating washers and sleeves - without their use the alternator will not function!**
3. The new case halves can now be assembled. Use the scribed lines on the old case as your guide. The assembly procedure should need little or no coaxing to go together. The new case bolts can be used to secure the two sections together and torque evenly.
4. Now you can remove the pin from the rear of the housing holding the brushes in place.
5. At this point, the alternator should spin freely. If not, loosen the fasteners and tap lightly until it spins easily then retighten the fasteners.
6. Reinstall the alternator and attach the correct wires to the terminals.
7. Adjust the belt tension so as not to cause bearing failure.
8. The battery cables can now be reinstalled. Double check all your electrical connections before starting the engine. Be sure the alternator is operating properly and correctly charging the battery

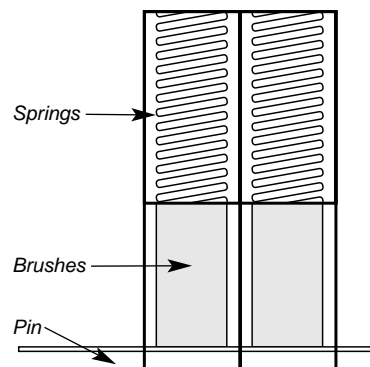

Illustration 1

Installation Instructions for 10152 Chrome Alternator Case

Tear-Down of Stock Alternator

1. Disconnect the battery negative (-) cable at the battery, then disconnect the positive (+) cable.
2. With the alternator still in position on the engine and the belt in place attempt to loosen the nut that secures the pulley. Do not apply unneeded force to remove the pulley at this time, it can also be removed on the workbench.
3. Label each of the wires to aid in the reinstallation of your alternator.
4. Scribe a line or mark the sides of the case where the front and rear sections meet in a fashion that will aid you in the reassembly process
5. Remove the three fasteners that attach the front and rear case halves together. The case halves can now be separated and remove the rotor and stator carefully.
6. Disassemble the nuts holding the insulators to the rear case. Remove the stator and rectifier unit.
7. Disassemble the brush holder mounting screws and remove the brush holder unit. (see Illustration 1)
8. Push the springs and brushes back into the holder and fabricate a 1" long wire (small diameter welding rod is ideal) and insert into the assembly hole. (see Illustration 2)

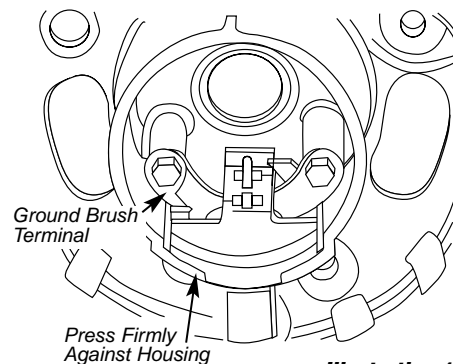

Illustration 1

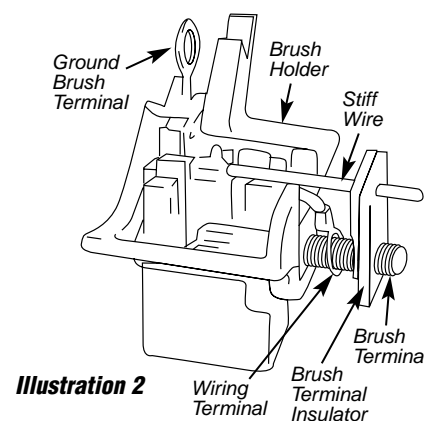

Illustration 2

Build-Up of the Chrome Case Alternator

1. Replace the brush holder unit in the rear case attaching it with the mounting fasteners from step 7 of the tear-down procedure. The retaining wire should be protruding from the back side of the housing. The brush wires must be routed in the same fashion as the original case. **One important point is the correct placement of the insulating washers and sleeves - without their use the alternator will not function!**
2. The stator and rectifier assembly should be repositioned in the rear case. Be sure the battery, stator and field terminals correspond to the correct location and the insulators have been reinstalled with the retaining nuts on the terminals.
3. If you chose to remove the pulley on the bench now is the time to do so. Place hex key wrench into the end of the shaft, to secure it and remove the nut with the proper size wrench.
4. Remove the pulley and fan off of the shaft, then remove the rotor from the bearing and case. Remove the screws holding the bearing retainer to the case.
5. Install the bearing retainer onto the chrome case. Be sure the rotor stop bushing is still on the shaft. Now slide the shaft into the bearing. Install the JEG'S chrome fan and pulley and secure the nut on the shaft.
6. The new case halves can now be assembled using the scribed lines as your guide. The assembly procedure should need little or no coaxing to go together. The new case bolts can be used to secure the two sections together and torque evenly.
7. Reinstall the alternator and attach the correct wires to the terminals.
8. Adjust the belt tension so as not to cause bearing failure.
9. The battery cables can now be reinstalled. Double check all your electrical connections before starting the engine. Be sure the alternator is operating properly and correctly charging the battery.

Installation Instructions for 10153 Chrome Alternator Case

Tear-Down of Stock Alternator

- 1.** Disconnect the battery negative (-) cable at the battery, then disconnect the positive (+) cable.
- 2.** Label each of the wires to aid in the reinstallation of your alternator. Scribe a line or mark the sides of the case where the front and rear sections meet in a fashion that will aid you in the reassembly process.
- 3.** Remove the brush holder unit from the rear of the case. (see Illustration 1)
- 4.** Remove the three bolts securing the case halves together and separate the case sections. The stator will remain with the rear case section.
- 5.** Now remove the nuts that attach the rectifier assembly and remove the stator. The rectifier assembly is detached by removing the remaining screws, condensor and battery terminal.

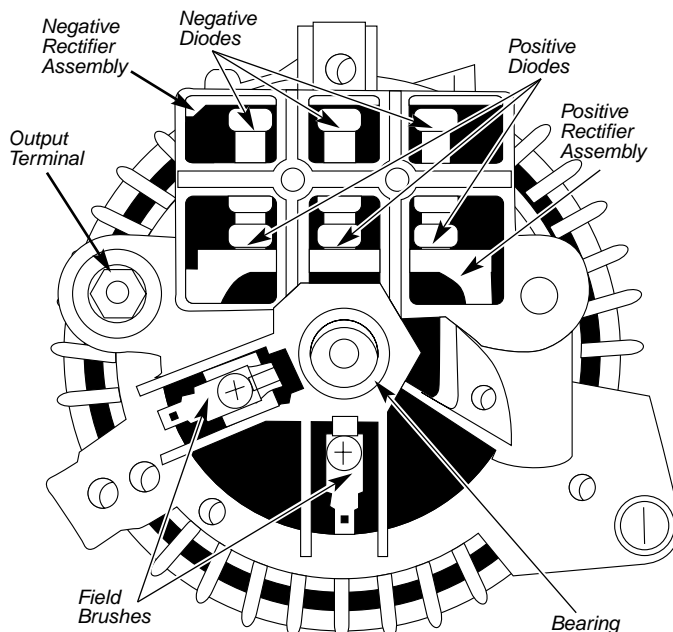

Illustration 1

Build-Up of the Chrome Case Alternator

- 1.** The rectifier assembly can be reinstalled into the new rear JEG'S chrome case half using all of the proper insulating washers. The brush holder unit is not to be replaced in this step, **THEY GO IN LAST.**
- 2.** The pulley will need to be removed from the rotor shaft. This procedure will need to be done in a press. If you do not have access to such equipment, go to your nearest auto parts store or machine shop. Reuse your stock pulley if it is a dual groove style. The JEG'S chrome drive end has a new bearing; you will need to reuse the stock retainer.
- 3.** With the new bearing pressed onto the rotor and the stock retainer fastened in place. Press the pulley onto the shaft using the bearing as the stop for its location.
- 4.** The case reassembly starts with the reuse of the mounting sleeve and the case halves united with the case fasteners.
- 5.** At this point, the alternator should spin freely. If not, loosen the fasteners and tap lightly until it spins easily then retighten the fasteners. If you cannot get the unit to spin freely the front bearing may not be pressed on properly (not far enough).
- 6.** Reinstall the brush unit and replace the alternator on your vehicle.
- 7.** Reinstall the alternator and attach the correct wires to the terminals.
- 8.** Adjust the belt tension so as not to cause bearing failure.
- 9.** The battery cables can now be reinstalled. Double check all your electrical connections before starting the engine. Be sure the alternator is operating properly and correctly charging the battery.