

Installation Instructions for 10230 Polyethylene Battery Box Kit

1. Read All of the Instructions Before Beginning your Installation.
2. Locate a desirable position for the battery and box. Ideally the area behind the right rear tire is the best location for weight transfer. Make sure that the area beneath the selected location is clear of all brake lines, electrical wiring, frame, fuel cell (gas tank), fuel lines and spare tire before drilling.
3. Insert the battery into the box and place the zinc plated hold down over the top of the battery. Center the battery in the box being careful to note (mark) the locations for the battery cables in reference to the terminals.
4. Slide the threaded rod into the hold down and mark the location of the holes to be drilled into the base of the battery box. Remove the box from the mounting location. Drill 13/32" holes into the base of the box.
5. Drill two 5/8" holes in the side of the box for the battery cables which were noted (marked) in step 3 and insert the two small grommets.
6. Using the base of the box as a template, mark the holes to be drilled in the mounting surface once again checking for clearance as described in step 2 prior to drilling the holes in the mounting surface. Use a center punch to dimple the mounting surface. Drill 13/32" holes into the mounting surface for the threaded rod.
7. Determine the location for the vent tube. Make certain that the tubing is routed away from any area that may collect fumes under the vehicle. Mark the box and the mounting surface. Once again check for clearance as described in step 2 prior to drilling the hole in the mounting surface. Use a center punch to dimple the mounting surface. Drill a 3/4" hole in the side of the box and the mounting surface. Insert the two large grommets.
8. Assemble the threaded rods with a nut about 2" from the bottom and insert through the base of the box and the mounting surface. Install a flat washer and a self locking nut from the bottom and snug into place. Do not fully tighten.
9. Insert the plastic vent tubing into the two large grommets to route any gases outside of the compartment.
10. Insert the battery into the box and place the hold down over the top of the battery and onto the threaded rods. Install the lock nuts onto the top of the threaded rods and snug into place. Adjust the threaded rod up or down depending on the height of your battery. Make certain that the lid will clear the top of the threaded rod assembly. Tighten the nuts securely.
11. Select a route for the battery cables avoiding objects that might damage the cable. Once again check for clearance.
12. Install the battery cables.
13. Attach and secure the lid with the countersunk allen head bolt, lock washer and nut assemblies.

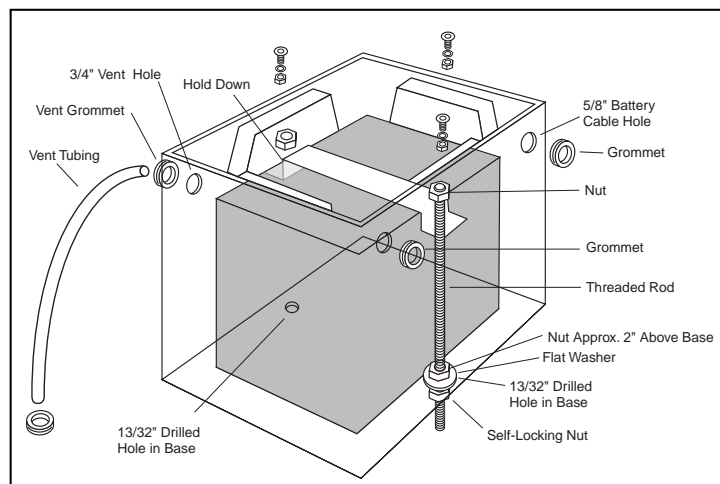

Accessories that may assist you in the installation:

1. Use Jeg's **Battery Cable Kit #555-10303**. Our kit also includes a ground strap to help eliminate charging and starting problems.
2. The Jeg's **Thru-Panel Connector #555-10317** may be used instead of a rubber grommet to run the positive cable to the solenoid or starter. Our connector has a stud and nut on both sides for quick and easy installation.
3. On race-only type vehicles we recommend the Jeg's **Positive and Negative Remote Charging Terminals #555-10315 and 555-10316** in addition to the Jeg's **Master Disconnect Switch and Faceplate #555-10305 and 555-10306**.



1-800-345-4545 jegs.com