

Installation Instructions for 30554 3" Muscle Car Header Dual Kits

**Application: 1967-81 Camaro & Firebird; 1962-79 Nova & Chevy II; 1972-79 Phoenix & Ventura;
1973-79 Omega; 1975 Apollo & 1975-79 Skylark (67-81 GM F-Body & 62-79 GM X-Body)
Not for convertible**

NOTE: This kit fits all listed V-8s with standard headers and with 3" collectors at the headers. The catalytic converters are not supplied with this exhaust system. This system is not legal for on-road use on vehicles that originally were equipped with a catalytic converter. Mufflers and headers are not included in this kit. We recommend offset inlet, center outlet muffler with approx. 14" body. Longer mufflers may fit; but you will need to trim from the extension pipe accordingly.

NOTE: For clearance of the 3" tail pipe at the rear, the lip of the rear quarter panel will need to be bent or trimmed for clearance, or a dent will need to be put in the tail pipe. The installation of this kit is for advanced installers only—cutting and welding may be necessary.

Kit Includes:

- | | | |
|------------------------|---------------------------------------|-------------------------|
| 4) ST4 Hangers | 4) Snapper Grommets | 1) Left Collector Pipe |
| 8) 3" Clamps | 2) F33 Flanges | 1) Right Collector Pipe |
| 6) 3/8" Nuts | 4) 5/16" X 1" Lag Screws | 1) Left Tail Pipe |
| 6) 3/8" Lock Washers | 2) MP48005 3" Collector Gaskets | 1) Right Tail Pipe |
| 6) 3/8" x 1-1/4" Bolts | 2) Left & Right Front Extension Pipes | |

DANGER WARNING:

Should the purchaser decide to install this exhaust product at home, be warned that pleasure car or light duty truck/van "bumper" jacks are intended for emergency use only. The use of frame contact jack stands in conjunction with a floor jack as main support is highly recommended to minimize accidental dropping of a vehicle while the installation proceeds. We recommend the use of a shop hoist if possible. Please use caution!

Limitation of Liability—Disclaimers: The regulation of emissions production, noise levels and safety standards is undertaken by the federal government, each of the fifty state legislatures, and by many local municipalities, towns and counties.

The manufacturer makes no warranties of merchantability, of fitness for a particular purpose, or that its products are approved for general use, or that its products comply with laws, regulations or ordinances in the states where they may be sold to the ultimate purchaser, the consumer.

The entire risk as to the conformity of this product in any such state and as to repair, should the product prove to be defective or non-conforming, is on the retail purchaser, the buyer, the ultimate consumer of such product and it is not upon the seller, distributor, or manufacturer.

In this connection, retail purchaser, the buyer, the ultimate consumer assumes the burden of the entire cost of any and all necessary service, alterations, and or repair.

The foregoing statement limits the liability of the manufacturer.

California vehicle code section 27156 prohibits the advertising, offering for sale, or installation of any device which modifies a vehicle's emission control system. This product is, therefore, not legal for sale or use in California on vehicles equipped with catalytic converters.



1-800-345-4545 **jegs.com**

NOTE: DO NOT TIGHTEN ANY BOLTS OR CLAMPS UNTIL THE LAST STEP!

NOTE: Due to different header designs, you may need to trim the ends of the pipes for proper fit. This kit has a 3" collector on the pipes. For those with 3-1/2" header collectors, you will need to cut this 3" collector off each pipe. We recommend using Jeg's 555-30007 (3-1/2" to 3" header collector kit). You will need to weld the collectors to the front pipes and install as necessary.

1. Remove the old exhaust system after the headers. Remove the old hangers and brackets.
2. Install the left and right collector pipes using the MP48005 gaskets and F33 flanges. Tighten only enough to hold in place, using the 3/8" x 1-1/4" bolts and nuts. NOTE: For vehicles requiring catalytic converters to meet EPA guidelines, catalytic converter #73-7774 or equivalent should be installed on the header collector pipes after the header collectors on the collector pipes.
3. Install the left and right front extension pipes to the collector pipes using 3" clamps. Be sure to leave adequate clearance between the floor boards and the drive shaft. NOTE: The extension pipes may be shortened to fit various header designs or different length mufflers.
4. Install the turbo mufflers (not included in this kit) onto the front extension pipes using 3" clamps. Rotate the front extension pipes to clear the driveshaft, frame, and general clearance.
5. Mount the hanger brackets to the existing holes in the frame behind the rear axle using the lag screws and the snapper grommet (see drawing). The hangers should be installed to the tail pipes where the tail pipes cross under the frame. Two additional hangers have been included to use at your preferred locations.
6. Install the left and right tail pipes to the mufflers using 3" clamps. Use a 3" clamp to connect the pipes and a hanger. You will need to modify the lip of the rear quarter panel for clearance.
7. Make sure that all the parts of the system are clear of frame members, hoses, suspension, and brake and fuel lines. Starting at the collector pipes, tighten all connections and nuts. Make sure all parts are clearing and will not leak or rattle. After several days of driving, retighten all bolts.

30554

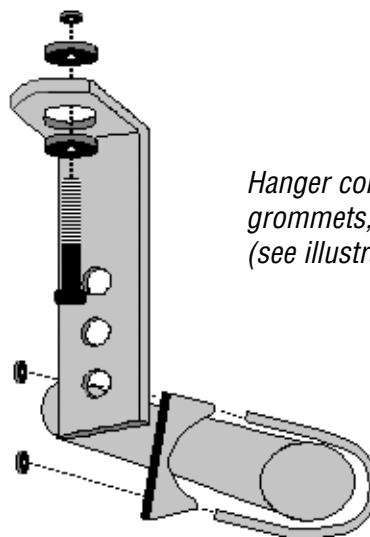
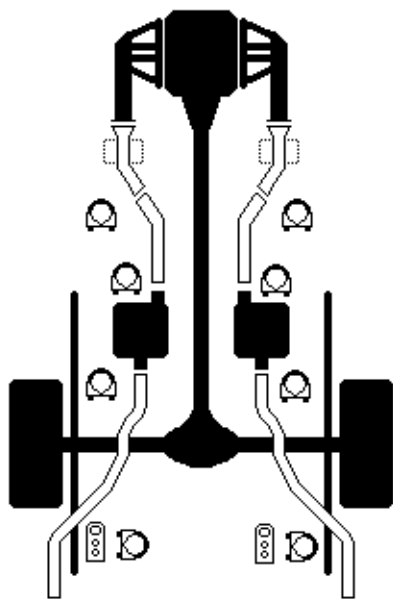

Hanger consists of a strap hanger, grommets, hardware, and clamp (see illustration)

Installation Instructions for 30555 3" Muscle Car Header Dual Kits

Application: 1964-72 Chevelle, Malibu & El Camino; 1965-72 Skylark, GS, Cutlass & 442; 1966-72 Le Mans, Tempest & GTO; 1969-72 Grand Prix & 70-72 Monte Carlo (GM A-Body)

NOTE: This kit fits all listed V-8s with standard headers and with 3" collectors at the headers. The catalytic converters are not supplied with this exhaust system. This system is not legal for on-road use on vehicles that originally were equipped with a catalytic converter. Mufflers and headers are not included in this kit. We recommend offset inlet, offset outlet muffler with approx. 14" body. Longer mufflers may fit; but you will need to trim from the extension pipe accordingly.

NOTE: For clearance of the 3" tail pipe at the rear, the lip of the rear quarter panel will need to be bent or trimmed for clearance, or a dent will need to be put in the tail pipe. The installation of this kit is for advanced installers only—cutting and welding may be necessary.

Kit Includes:

- | | | |
|--------------------------|-------------------------------|---------------------------------|
| 6) 3/8" Nuts | 1) Left Collector Pipe | 2) Snapper Grommets |
| 6) 3/8" x 1-1/4" Bolts | 1) Right Collector Pipe | 2) MP48005 3" Collector Gaskets |
| 6) 3/8" Lock Washers | 1) Left Tail Pipe | 2) F33 Flanges |
| 2) 5/16" Nuts | 1) Right Tail Pipe | 2) LB9 Hangers |
| 2) 5/16" x 1" Bolts | 1) Left Over-The-Axle Pipe | 2) BR1 Hangers (BR755) |
| 4) 5/16" x 1" Lag Screws | 1) Right Over-The-Axle Pipe | 2) THU400 Hangers (BR104) |
| 2) Fender Washers | 1) Left Front Extension Pipe | |
| 10) 3" Clamps | 1) Right Front Extension Pipe | |

DANGER WARNING:

Should the purchaser decide to install this exhaust product at home, be warned that pleasure car or light duty truck/van "bumper" jacks are intended for emergency use only. The use of frame contact jack stands in conjunction with a floor jack as main support is highly recommended to minimize accidental dropping of a vehicle while the installation proceeds. We recommend the use of a shop hoist if possible. Please use caution!

Limitation of Liability—Disclaimers: The regulation of emissions production, noise levels and safety standards is undertaken by the federal government, each of the fifty state legislatures, and by many local municipalities, towns and counties.

The manufacturer makes no warranties of merchantability, of fitness for a particular purpose, or that its products are approved for general use, or that its products comply with laws, regulations or ordinances in the states where they may be sold to the ultimate purchaser, the consumer.

The entire risk as to the conformity of this product in any such state and as to repair, should the product prove to be defective or non-conforming, is on the retail purchaser, the buyer, the ultimate consumer of such product and it is not upon the seller, distributor, or manufacturer.

In this connection, retail purchaser, the buyer, the ultimate consumer assumes the burden of the entire cost of any and all necessary service, alterations, and or repair.

The foregoing statement limits the liability of the manufacturer.

California vehicle code section 27156 prohibits the advertising, offering for sale, or installation of any device which modifies a vehicle's emission control system. This product is, therefore, not legal for sale or use in California on vehicles equipped with catalytic converters.



1-800-345-4545 **jegs.com**

NOTE: DO NOT TIGHTEN ANY BOLTS OR CLAMPS UNTIL THE LAST STEP!

NOTE: Due to different header designs, you may need to trim the ends of the pipes for proper fit. This kit has a 3" collector on the pipes. For those with 3-1/2" header collectors, you will need to cut this 3" collector off each pipe. We recommend using Jeg's 555-30007 (3-1/2" to 3" header collector kit). You will need to weld the collectors to the front pipes and install as necessary.

1. Raise the automobile in a safe and suitable manner—support with jack stands onto the frame.
2. Remove the old exhaust system after the headers. Remove the old hangers and brackets if desired. New universal hangers are included in this kit to replace the original hangers.
3. Install the left and right collector pipes using the MP48005 gaskets and F33 flanges. Tighten only enough to hold in place, using the 3/8" x 1-1/4" bolts and nuts.
4. Install the left and right front extension pipes to the collector pipes using 3" clamps. Be sure to leave adequate clearance between the floor boards and the drive shaft.
5. Install the mufflers (not included in this kit) onto the front extension pipes using 3" clamps. Rotate the front extension pipes to clear the driveshaft, frame, and general clearance.
6. Mount the hanger brackets if necessary to the frame using the LB9 strap with the grommets and lag screw behind the mufflers, and the bracket, lag screw, and THU400 rubber hanger at the end of the tail pipes. Connect the hangers to the pipes using the 3" clamps.
7. Install the left and right over-the-axle pipes to the mufflers using 3" clamps. Install the left and right tail pipes to the over-the-axle pipes using 3" clamps. Use a 3" clamp to connect the pipes and a hanger at the rear. Cut the tail pipes to your desired length and look.
8. Make sure that all the parts of the system are clear of frame members, hoses, suspension, and brake and fuel lines. Starting at the collector pipes, tighten all connections and nuts. Make sure all parts are clearing and will not leak or rattle. After several days of driving, retighten all bolts.

30555

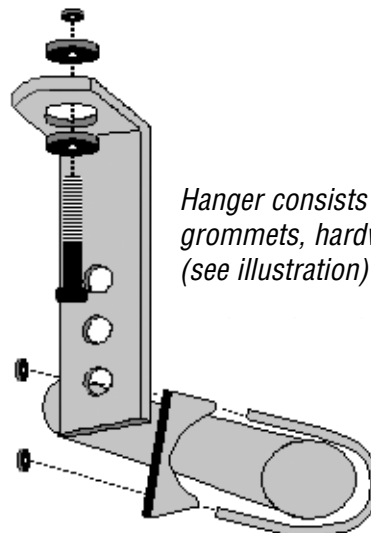
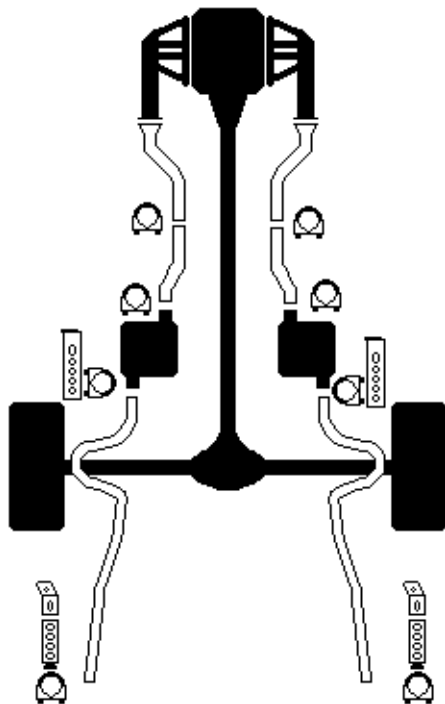

JEG'S
Performance Products

1-800-345-4545

jegs.com