

## **Installation Instructions for 30560 3" Universal Header Dual Kits (3" to 2-1/4" Pipe)**

**Application:** Fits vehicles with standard full-length headers with 3" collectors.

NOTE: Catalytic converters are not included with this exhaust system. Headers are not included in this kit. Mufflers are not included in this kit. This system is not legal for on-road use on vehicles that originally were equipped with a catalytic converter.

### **Kit Includes:**

- |                              |                                     |                            |
|------------------------------|-------------------------------------|----------------------------|
| 4) 5/16" x 1" Bolt           | 4) THU400 (BR104) Hangers           | 2) F33 Flanges (3 Bolt 3") |
| 4) 5/16" x 1-1/4" Lag Screws | 2) ST4 Hangers                      | 4) Fender Washers          |
| 4) 5/16" x 1-1/2" Bolts      | 2) LB7 Hangers                      | 4) BA121 Snapper Grommets  |
| 8) 5/16" Nuts                | 4) BR755 Hanger Brackets            | 4) ID/OD Extensions        |
| 6) 3/8" x 1-1/4" Bolts       | 10) 2-1/4" Clamps                   | 2) MP48005 Gaskets         |
| 6) 3/8" Lock Washers         | 2) 90-Degree Tail Pipes             |                            |
| 6) 3/8" Nuts                 | 2) 3" to 2-1/4" Flex Joint Reducers |                            |

### **DANGER WARNING:**

Should the purchaser decide to install this exhaust product at home, be warned that pleasure car or light duty truck/van "bumper" jacks are intended for emergency use only. The use of frame contact jack stands in conjunction with a floor jack as main support is highly recommended to minimize accidental dropping of a vehicle while the installation proceeds. We recommend the use of a shop hoist if possible. Please use caution!

**Limitation of Liability–Disclaimers:** The regulation of emissions production, noise levels and safety standards is undertaken by the federal government, each of the fifty state legislatures, and by many local municipalities, towns and counties.

The manufacturer makes no warranties of merchantability, of fitness for a particular purpose, or that its products are approved for general use, or that its products comply with laws, regulations or ordinances in the states where they may be sold to the ultimate purchaser, the consumer.

The entire risk as to the conformity of this product in any such state and as to repair, should the product prove to be defective or non-conforming, is on the retail purchaser, the buyer, the ultimate consumer of such product and it is not upon the seller, distributor, or manufacturer.

In this connection, retail purchaser, the buyer, the ultimate consumer assumes the burden of the entire cost of any and all necessary service, alterations, and or repair.

The foregoing statement limits the liability of the manufacturer.

California vehicle code section 27156 prohibits the advertising, offering for sale, or installation of any device which modifies a vehicle's emission control system. This product is, therefore, not legal for sale or use in California on vehicles equipped with catalytic converters.



**1-800-345-4545**    **jegs.com**

**NOTE: DO NOT TIGHTEN ANY BOLTS OR CLAMPS UNTIL THE LAST STEP!**

1. Remove the old exhaust system after the headers. Remove the old hangers and brackets.
2. Install the flex joint reducers to the header collectors using the MP48005 gaskets and F33 flanges. Tighten only enough to hold in place using the 3/8" x 1-1/4" bolts and nuts. NOTE: The flex joint can be cut off ahead of the welded joint should you not need the flexibility. NOTE: For vehicles requiring catalytic converters to meet EPA guidelines, catalytic converter #73-7774 or equivalent should be installed somewhere between the collectors and mufflers.
3. Install the ID/OD extension pipes using 2-1/4" clamps to the flex joint reducers to both sides. Be sure to leave adequate clearance between the floor boards and the drive shaft. The extension pipes may need to be rotated for clearance. NOTE: The extension pipes may be shortened to fit various header designs or different length mufflers.
4. Install the mufflers (not included in this kit) onto the front extension pipes using 2-1/4" clamps. Rotate the front extension pipes to clear the driveshaft, frame, and general clearance. Install the mufflers so as to maximize clearance on the vehicle.
5. At the inlet of the mufflers, mount a universal THU400 hanger to the existing holes in the frame (drill a hole if none present) using a lag screw for both sides of the vehicle. Use a 2-1/4" clamp to attach to the connecting point of the extension pipe and the muffler.
6. Install the left and right tail pipes to the mufflers using 2-1/4" clamps. You may need to trim the tail pipes to length. NOTE: The tail pipes exit in front of the rear wheels.
7. After the tail pipes, mount a universal THU400 hanger to the existing holes in the frame (drill a hole if none present) using a lag screw and 2-1/4" clamp, for both sides of the vehicle. You may do so at the outlet of the mufflers, or the connecting point of the tail pipe and rear extension pipe.
8. Use a 2-1/4" clamp to connect the rear extension pipes to the tail pipes.
9. Two additional clamps, four extra hangers with grommets and hardware, and four extra hanger brackets with hardware are included in this kit. Use as necessary on the system.
10. Make sure that all the parts of the system are clear of frame members, hoses, suspension, and brake and fuel lines. Starting at the collector pipes, tighten all connections and nuts. Make sure all parts are clearing and will not leak or rattle. After several days of driving, retighten all bolts.

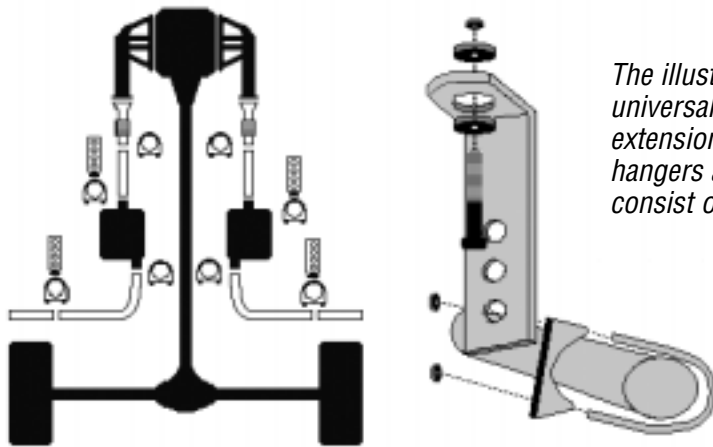

*The illustration shows just one example of how the universal dual kit can run. You may install the 15" extension pipes in other locations. Additional clamps and hangers are included for use as necessary. The hangers consist of a grommet, hanger, hardware and clamp.*

## **Installation Instructions for 30561 3" Universal Header Dual Kits (3" to 2-1/2" Pipe)**

**Application: Fits vehicles with standard full-length headers with 3" collectors.**

NOTE: Catalytic converters are not included with this exhaust system. Headers are not included in this kit. Mufflers are not included in this kit. This system is not legal for on-road use on vehicles that originally were equipped with a catalytic converter.

### **Kit Includes:**

- |                              |                                     |                            |
|------------------------------|-------------------------------------|----------------------------|
| 4) 5/16" x 1" Bolt           | 4) THU400 (BR104) Hangers           | 2) F33 Flanges (3 Bolt 3") |
| 4) 5/16" x 1-1/4" Lag Screws | 2) ST4 Hangers                      | 4) Fender Washers          |
| 4) 5/16" x 1-1/2" Bolts      | 2) LB7 Hangers                      | 4) BA121 Snapper Grommets  |
| 8) 5/16" Nuts                | 4) BR755 Hanger Brackets            | 4) ID/OD Extensions        |
| 6) 3/8" x 1-1/4" Bolts       | 10) 2-1/2" Clamps                   | 2) MP48005 Gaskets         |
| 6) 3/8" Lock Washers         | 2) 90-Degree Tail Pipes             |                            |
| 6) 3/8" Nuts                 | 2) 3" to 2-1/2" Flex Joint Reducers |                            |

### **DANGER WARNING:**

Should the purchaser decide to install this exhaust product at home, be warned that pleasure car or light duty truck/van "bumper" jacks are intended for emergency use only. The use of frame contact jack stands in conjunction with a floor jack as main support is highly recommended to minimize accidental dropping of a vehicle while the installation proceeds. We recommend the use of a shop hoist if possible. Please use caution!

**Limitation of Liability–Disclaimers:** The regulation of emissions production, noise levels and safety standards is undertaken by the federal government, each of the fifty state legislatures, and by many local municipalities, towns and counties.

The manufacturer makes no warranties of merchantability, of fitness for a particular purpose, or that its products are approved for general use, or that its products comply with laws, regulations or ordinances in the states where they may be sold to the ultimate purchaser, the consumer.

The entire risk as to the conformity of this product in any such state and as to repair, should the product prove to be defective or non-conforming, is on the retail purchaser, the buyer, the ultimate consumer of such product and it is not upon the seller, distributor, or manufacturer.

In this connection, retail purchaser, the buyer, the ultimate consumer assumes the burden of the entire cost of any and all necessary service, alterations, and or repair.

The foregoing statement limits the liability of the manufacturer.

California vehicle code section 27156 prohibits the advertising, offering for sale, or installation of any device which modifies a vehicle's emission control system. This product is, therefore, not legal for sale or use in California on vehicles equipped with catalytic converters.



**1-800-345-4545**    **jegs.com**

**NOTE: DO NOT TIGHTEN ANY BOLTS OR CLAMPS UNTIL THE LAST STEP!**

1. Remove the old exhaust system after the headers. Remove the old hangers and brackets.
2. Install the flex joint reducers to the header collectors using the MP48005 gaskets and F33 flanges. Tighten only enough to hold in place using the 3/8" x 1-1/4" bolts and nuts. NOTE: The flex joint can be cut off ahead of the welded joint should you not need the flexibility. NOTE: For vehicles requiring catalytic converters to meet EPA guidelines, catalytic converter #73-7774 or equivalent should be installed somewhere between the collectors and mufflers.
3. Install the ID/OD extension pipes using 2-1/2" clamps to the flex joint reducers to both sides. Be sure to leave adequate clearance between the floor boards and the drive shaft. The extension pipes may need to be rotated for clearance. NOTE: The extension pipes may be shortened to fit various header designs or different length mufflers.
4. Install the mufflers (not included in this kit) onto the front extension pipes using 2-1/2" clamps. Rotate the front extension pipes to clear the driveshaft, frame, and general clearance. Install the mufflers so as to maximize clearance on the vehicle.
5. At the inlet of the mufflers, mount a universal hanger to the existing holes in the frame (drill a hole if none present) using a lag screw for both sides of the vehicle. Use a 2-1/2" clamp to attach to the connecting point of the extension pipe and the mufflers.
6. Install the left and right tail pipes to the mufflers using 2-1/2" clamps. You may need to trim the tail pipes to length. NOTE: The tail pipes exit in front of the rear wheels.
7. After the tail pipes, mount a universal hanger THU400 to the existing holes in the frame (drill a hole if none present) using a lag screw and 2-1/2" clamp, for both sides of the vehicle. You may do so at the outlet of the mufflers, or the connecting point of the tail pipe and rear extension pipe.
8. Use a 2-1/2" clamp to connect the rear extension pipes to the tail pipes.
9. Two additional clamps, four extra hangers with grommets and hardware, and four extra hanger brackets with hardware are included in this kit. Use as necessary on the system.
10. Make sure that all the parts of the system are clear of frame members, hoses, suspension, and brake and fuel lines. Starting at the collector pipes, tighten all connections and nuts. Make sure all parts are clearing and will not leak or rattle. After several days of driving, retighten all bolts.

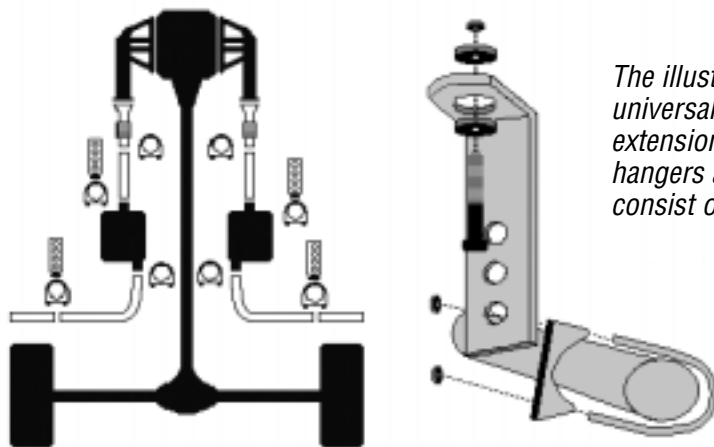

*The illustration shows just one example of how the universal dual kit can run. You may install the 15" extension pipes in other locations. Additional clamps and hangers are included for use as necessary. The hangers consist of a grommet, hanger, hardware and clamp.*

## **Installation Instructions for 30562 3" Universal Header Dual Kits (3" to 3" Pipe)**

**Application:** Fits vehicles with standard full-length headers with 3" collectors.

NOTE: Catalytic converters are not included with this exhaust system. Headers are not included in this kit. Mufflers are not included in this kit. This system is not legal for on-road use on vehicles that originally were equipped with a catalytic converter.

### **Kit Includes:**

- |                              |                                 |                            |
|------------------------------|---------------------------------|----------------------------|
| 4) 5/16" x 1" Bolt           | 4) THU400 (BR104) Hangers       | 2) F33 Flanges (3 Bolt 3") |
| 4) 5/16" x 1-1/4" Lag Screws | 2) ST4 Hangers                  | 4) Fender Washers          |
| 4) 5/16" x 1-1/2" Bolts      | 2) LB7 Hangers                  | 4) BA121 Snapper Grommets  |
| 8) 5/16" Nuts                | 4) Hanger Brackets              | 4) ID/OD Extensions        |
| 6) 3/8" x 1-1/4" Bolts       | 10) 3" Clamps                   | 2) MP48005 Gaskets         |
| 6) 3/8" Lock Washers         | 2) 90-Degree Tail Pipes         |                            |
| 6) 3/8" Nuts                 | 2) 3" to 3" Flex Joint Reducers |                            |

### **DANGER WARNING:**

Should the purchaser decide to install this exhaust product at home, be warned that pleasure car or light duty truck/van "bumper" jacks are intended for emergency use only. The use of frame contact jack stands in conjunction with a floor jack as main support is highly recommended to minimize accidental dropping of a vehicle while the installation proceeds. We recommend the use of a shop hoist if possible. Please use caution!

**Limitation of Liability–Disclaimers:** The regulation of emissions production, noise levels and safety standards is undertaken by the federal government, each of the fifty state legislatures, and by many local municipalities, towns and counties.

The manufacturer makes no warranties of merchantability, of fitness for a particular purpose, or that its products are approved for general use, or that its products comply with laws, regulations or ordinances in the states where they may be sold to the ultimate purchaser, the consumer.

The entire risk as to the conformity of this product in any such state and as to repair, should the product prove to be defective or non-conforming, is on the retail purchaser, the buyer, the ultimate consumer of such product and it is not upon the seller, distributor, or manufacturer.

In this connection, retail purchaser, the buyer, the ultimate consumer assumes the burden of the entire cost of any and all necessary service, alterations, and or repair.

The foregoing statement limits the liability of the manufacturer.

California vehicle code section 27156 prohibits the advertising, offering for sale, or installation of any device which modifies a vehicle's emission control system. This product is, therefore, not legal for sale or use in California on vehicles equipped with catalytic converters.



**1-800-345-4545**    **jegs.com**

**NOTE: DO NOT TIGHTEN ANY BOLTS OR CLAMPS UNTIL THE LAST STEP!**

1. Remove the old exhaust system after the headers. Remove the old hangers and brackets.
2. Install the flex joint reducers to the header collectors using the MP48005 gaskets and F33 flanges (on the flex joints). Tighten only enough to hold in place using the 3/8" x 1-1/4" bolts and nuts. NOTE: The flex joint can be cut off ahead of the welded joint should you not need the flexibility. NOTE: For vehicles requiring catalytic converters to meet EPA guidelines, catalytic converter #73-7774 or equivalent should be installed somewhere between the collectors and mufflers.
3. Install the ID/OD extension pipes using 3" clamps to the flex joint reducers to both sides. Be sure to leave adequate clearance between the floor boards and the drive shaft. The extension pipes may need to be rotated for clearance. NOTE: The extension pipes may be shortened to fit various header designs or different length mufflers.
4. Install the mufflers (not included in this kit) onto the front extension pipes using 3" clamps. Rotate the front extension pipes to clear the driveshaft, frame, and general clearance. Install the mufflers so as to maximize clearance on the vehicle.
5. At the inlet of the mufflers, mount a universal hanger to the existing holes in the frame (drill a hole if none present) using a lag screw for both sides of the vehicle. Use a 3" clamp to attach to the connecting point of the extension pipe and the mufflers.
6. Install the left and right tail pipes to the mufflers using 3" clamps. You may need to trim the tail pipes to length. NOTE: The tail pipes exit in front of the rear wheels.
7. After the tail pipes, mount a universal THU400 hanger to the existing holes in the frame (drill a hole if none present) using a lag screw and 3" clamp, for both sides of the vehicle. You may do so at the outlet of the mufflers, or the connecting point of the tail pipe and rear extension pipe.
8. Use a 3" clamp to connect the rear extension pipes to the tail pipes.
9. Two additional clamps, four extra hangers with grommets and hardware, and four extra hanger brackets with hardware are included in this kit. Use as necessary on the system.
10. Make sure that all the parts of the system are clear of frame members, hoses, suspension, and brake and fuel lines. Starting at the collector pipes, tighten all connections and nuts. Make sure all parts are clearing and will not leak or rattle. After several days of driving, retighten all bolts.

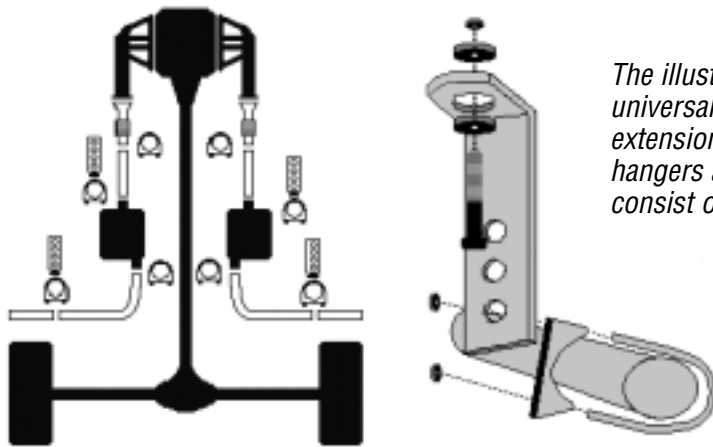

*The illustration shows just one example of how the universal dual kit can run. You may install the 15" extension pipes in other locations. Additional clamps and hangers are included for use as necessary. The hangers consist of a grommet, hanger, hardware and clamp.*

## **Installation Instructions for 30563 3-1/2" Universal Header Dual Kits (3-1/2" to 2-1/2" Pipe)**

**Application: Fits vehicles with standard full-length headers with 3-1/2" collectors.**

NOTE: Catalytic converters are not included with this exhaust system. Headers are not included in this kit. Mufflers are not included in this kit. This system is not legal for on-road use on vehicles that originally were equipped with a catalytic converter.

### **Kit Includes:**

- |                              |   |                                 |
|------------------------------|---|---------------------------------|
| 4) 5/16" x 1" Bolt           | 4) THU400 )BR104) Hangers               | 2) F312 Flanges (3 Bolt 3-1/2") |
| 4) 5/16" x 1-1/4" Lag Screws | 2) ST4 Hangers                          | 4) Fender Washers               |
| 4) 5/16" x 1-1/2" Bolts      | 2) LB7 Hangers                          | 4) BA121 Snapper Grommets       |
| 8) 5/16" Nuts                | 4) BR755 Hanger Brackets                | 4) ID/OD Extensions             |
| 6) 3/8" x 1-1/4" Bolts       | 10) 2-1/2" Clamps                       | 2) MP48006 Gaskets              |
| 6) 3/8" Lock Washers         | 2) 90-Degree Tail Pipes                 |                                 |
| 6) 3/8" Nuts                 | 2) 3-1/2" to 2-1/2" Flex Joint Reducers |                                 |

### **DANGER WARNING:**

Should the purchaser decide to install this exhaust product at home, be warned that pleasure car or light duty truck/van "bumper" jacks are intended for emergency use only. The use of frame contact jack stands in conjunction with a floor jack as main support is highly recommended to minimize accidental dropping of a vehicle while the installation proceeds. We recommend the use of a shop hoist if possible. Please use caution!

**Limitation of Liability–Disclaimers:** The regulation of emissions production, noise levels and safety standards is undertaken by the federal government, each of the fifty state legislatures, and by many local municipalities, towns and counties.

The manufacturer makes no warranties of merchantability, of fitness for a particular purpose, or that its products are approved for general use, or that its products comply with laws, regulations or ordinances in the states where they may be sold to the ultimate purchaser, the consumer.

The entire risk as to the conformity of this product in any such state and as to repair, should the product prove to be defective or non-conforming, is on the retail purchaser, the buyer, the ultimate consumer of such product and it is not upon the seller, distributor, or manufacturer.

In this connection, retail purchaser, the buyer, the ultimate consumer assumes the burden of the entire cost of any and all necessary service, alterations, and or repair.

The foregoing statement limits the liability of the manufacturer.

California vehicle code section 27156 prohibits the advertising, offering for sale, or installation of any device which modifies a vehicle's emission control system. This product is, therefore, not legal for sale or use in California on vehicles equipped with catalytic converters.



**1-800-345-4545**    **jegs.com**

**NOTE: DO NOT TIGHTEN ANY BOLTS OR CLAMPS UNTIL THE LAST STEP!**

1. Remove the old exhaust system after the headers. Remove the old hangers and brackets.
2. Install the flex joint reducers to the header collectors using the MP48006 gaskets and F312 flanges. Tighten only enough to hold in place using the 3/8" x 1-1/4" bolts and nuts. NOTE: The flex joint can be cut off ahead of the welded joint should you not need the flexibility. NOTE: For vehicles requiring catalytic converters to meet EPA guidelines, catalytic converter #73-7774 or equivalent should be installed somewhere between the collectors and mufflers.
3. Install the ID/OD extension pipes using 2-1/2" clamps to the flex joint reducers to both sides. Be sure to leave adequate clearance between the floor boards and the drive shaft. The extension pipes may need to be rotated for clearance. NOTE: The extension pipes may be shortened to fit various header designs or different length mufflers.
4. Install the mufflers (not included in this kit) onto the front extension pipes using 2-1/2" clamps. Rotate the front extension pipes to clear the driveshaft, frame, and general clearance. Install the mufflers so as to maximize clearance on the vehicle.
5. At the inlet of the mufflers, mount a universal THU400 hanger to the existing holes in the frame (drill a hole if none present) using a lag screw for both sides of the vehicle. Use a 2-1/2" clamp to attach to the connecting point of the extension pipe and the mufflers.
6. Install the left and right tail pipes to the mufflers using 2-1/2" clamps. You may need to trim the tail pipes to length. NOTE: The tail pipes exit in front of the rear wheels.
7. After the tail pipes, mount a universal hanger to the existing holes in the frame (drill a hole if none present) using a lag screw and 2-1/2" clamp, for both sides of the vehicle. You may do so at the outlet of the mufflers, or the connecting point of the tail pipe and rear extension pipe.
8. Use a 2-1/2" clamp to connect the rear extension pipes to the tail pipes.
9. Two additional clamps, four extra hangers with grommets and hardware, and four extra hanger brackets with hardware are included in this kit. Use as necessary on the system.
10. Make sure that all the parts of the system are clear of frame members, hoses, suspension, and brake and fuel lines. Starting at the collector pipes, tighten all connections and nuts. Make sure all parts are clearing and will not leak or rattle. After several days of driving, retighten all bolts.

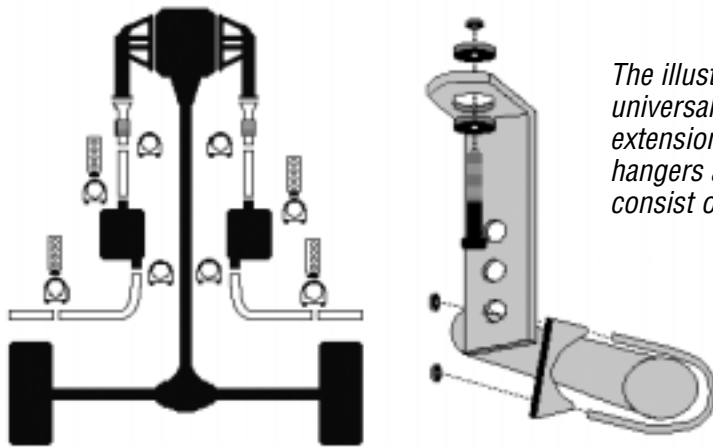

*The illustration shows just one example of how the universal dual kit can run. You may install the 15" extension pipes in other locations. Additional clamps and hangers are included for use as necessary. The hangers consist of a grommet, hanger, hardware and clamp.*



## **Installation Instructions for 30564 3-1/2" Universal Header Dual Kits (3-1/2" to 3" Pipe)**

**Application: Fits vehicles with standard full-length headers with 3-1/2" collectors.**

NOTE: Catalytic converters are not included with this exhaust system. Headers are not included in this kit. Mufflers are not included in this kit. This system is not legal for on-road use on vehicles that originally were equipped with a catalytic converter.

### **Kit Includes:**

- |                              |                                     |                                 |
|------------------------------|-------------------------------------|---------------------------------|
| 4) 5/16" x 1" Bolt           | 4) THU400 (BR104) Hangers           | 2) F312 Flanges (3 Bolt 3-1/2") |
| 4) 5/16" x 1-1/4" Lag Screws | 2) ST4 Hangers                      | 4) Fender Washers               |
| 4) 5/16" x 1-1/2" Bolts      | 2) LB7 Hangers                      | 4) BA121 Snapper Grommets       |
| 8) 5/16" Nuts                | 4) BR755 Hanger Brackets            | 4) ID/OD Extensions             |
| 6) 3/8" x 1-1/4" Bolts       | 10) 3" Clamps                       | 2) MP48006 Gaskets              |
| 6) 3/8" Lock Washers         | 2) 90-Degree Tail Pipes             |                                 |
| 6) 3/8" Nuts                 | 2) 3-1/2" to 3" Flex Joint Reducers |                                 |

### **DANGER WARNING:**

Should the purchaser decide to install this exhaust product at home, be warned that pleasure car or light duty truck/van "bumper" jacks are intended for emergency use only. The use of frame contact jack stands in conjunction with a floor jack as main support is highly recommended to minimize accidental dropping of a vehicle while the installation proceeds. We recommend the use of a shop hoist if possible. Please use caution!

**Limitation of Liability–Disclaimers:** The regulation of emissions production, noise levels and safety standards is undertaken by the federal government, each of the fifty state legislatures, and by many local municipalities, towns and counties.

The manufacturer makes no warranties of merchantability, of fitness for a particular purpose, or that its products are approved for general use, or that its products comply with laws, regulations or ordinances in the states where they may be sold to the ultimate purchaser, the consumer.

The entire risk as to the conformity of this product in any such state and as to repair, should the product prove to be defective or non-conforming, is on the retail purchaser, the buyer, the ultimate consumer of such product and it is not upon the seller, distributor, or manufacturer.

In this connection, retail purchaser, the buyer, the ultimate consumer assumes the burden of the entire cost of any and all necessary service, alterations, and or repair.

The foregoing statement limits the liability of the manufacturer.

California vehicle code section 27156 prohibits the advertising, offering for sale, or installation of any device which modifies a vehicle's emission control system. This product is, therefore, not legal for sale or use in California on vehicles equipped with catalytic converters.



**1-800-345-4545**    **jegs.com**

**NOTE: DO NOT TIGHTEN ANY BOLTS OR CLAMPS UNTIL THE LAST STEP!**

1. Remove the old exhaust system after the headers. Remove the old hangers and brackets.
2. Install the flex joint reducers to the header collectors using the MP48006gaskets and F312 flanges. Tighten only enough to hold in place using the 3/8" x 1-1/4" bolts and nuts. NOTE: The flex joint can be cut off ahead of the welded joint should you not need the flexibility. NOTE: For vehicles requiring catalytic converters to meet EPA guidelines, catalytic converter #73-7774 or equivalent should be installed somewhere between the collectors and mufflers.
3. Install the ID/OD extension pipes using 3" clamps to the flex joint reducers to both sides. Be sure to leave adequate clearance between the floor boards and the drive shaft. The extension pipes may need to be rotated for clearance. NOTE: The extension pipes may be shortened to fit various header designs or different length mufflers.
4. Install the mufflers (not included in this kit) onto the front extension pipes using 3" clamps. Rotate the front extension pipes to clear the driveshaft, frame, and general clearance. Install the mufflers so as to maximize clearance on the vehicle.
5. At the inlet of the mufflers, mount a universal THU400 hanger to the existing holes in the frame (drill a hole if none present) using a lag screw for both sides of the vehicle. Use a 3" clamp to attach to the connecting point of the extension pipe and the muffler.
6. Install the left and right tail pipes to the mufflers using 3" clamps. You may need to trim the tail pipes to length. NOTE: The tail pipes exit in front of the rear wheels.
7. After the tail pipes, mount a universal THU400 hanger to the existing holes in the frame (drill a hole if none present) using a lag screw and 3" clamp, for both sides of the vehicle. You may do so at the outlet of the mufflers, or the connecting point of the tail pipe and rear extension pipe.
8. Use a 3" clamp to connect the rear extension pipes to the tail pipes.
9. Two additional clamps, four extra hangers with grommets and hardware, and four extra hanger brackets with hardware are included in this kit. Use as necessary on the system.
10. Make sure that all the parts of the system are clear of frame members, hoses, suspension, and brake and fuel lines. Starting at the collector pipes, tighten all connections and nuts. Make sure all parts are clearing and will not leak or rattle. After several days of driving, retighten all bolts.

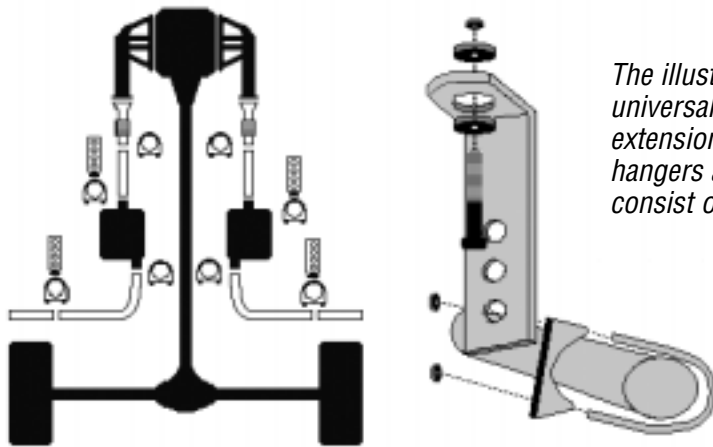

*The illustration shows just one example of how the universal dual kit can run. You may install the 15" extension pipes in other locations. Additional clamps and hangers are included for use as necessary. The hangers consist of a grommet, hanger, hardware and clamp.*