

Installation Instructions for 2-1/16" Volts, Temp, Pressure & Fuel Level Gauge

Before You Start

This gauge features peak recall, programmable high and low full dial warning and external warning output. Please read instructions completely before installing.

- **ALWAYS WEAR SAFETY GLASSES.**
- Install gauge only when engine is cool and ignition is off.
- Make sure all necessary tools, materials, and parts are on hand.
- Disconnect negative (-) battery cable before installing gauge.
- 2-1/16" gauge mounts in a 2-1/16" diameter hole.
- Make sure mounting location does not impair visibility or interfere with driving. Also check behind the mounting location for any wiring or components before drilling.

Fig 1. Wiring Diagram

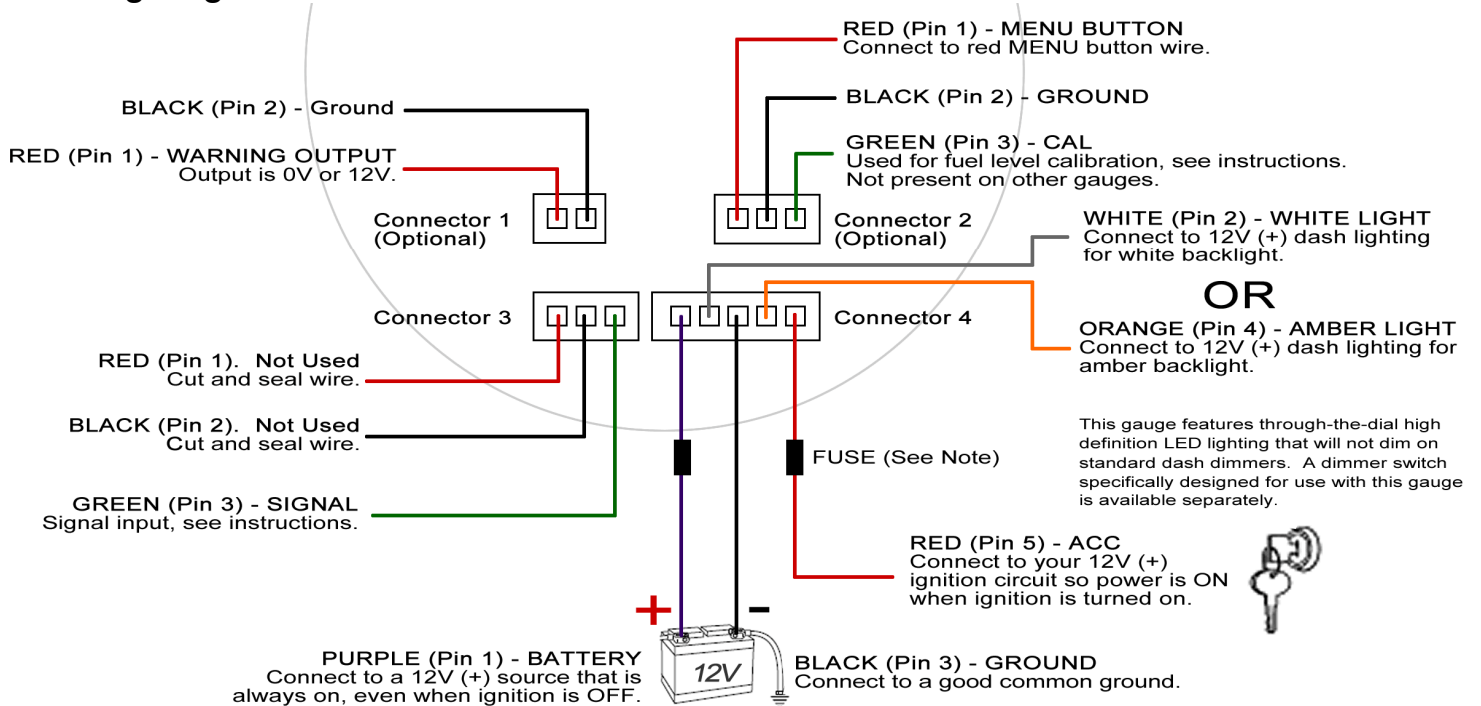

Wiring

Use 20 AWG stranded or heavier wire for installation. Route wires away from any moving parts and hot engine components. Secure wires firmly along their route. **Cut and seal all unused wire connections.**

Note: As a safety precaution, the RED (Pin 5) and PURPLE (Pin 1) 12V+ connections should be fused. We recommend using a 1 Amp, fast-acting type cartridge fuse.

Temperature Signal Input

Connect one sender terminal to common ground. Connect the second sender terminal to gauge signal input (Pin 3, Connector 3).

Make sure that the gauge and sending unit have a good common ground, i.e. ground the gauge and sending unit at the same location.

Volts Signal Input

Connect a switched 12V+ source (i.e. ignition) to gauge signal input (Pin 3, Connector 3).

Fuel Level Signal Input

Connect the gauge signal input wire (GREEN wire on Connector 3, Pin 3) to the fuel level sender terminal.

Make sure that the gauge and sending unit have a good common ground, i.e. ground the gauge and sending unit at the same location.

MENU Button Installation

Installation of the remote MENU button is only necessary if you want to use the RECALL and WARNING features of the gauge

Mount the included MENU button in a location that is convenient. Connect the red wire from the button to Connector 2, Pin 1 (Red) and the black wire on the button to Connector 2, Pin 2 (Black). See Fig 1.

Pressure Signal Input

Connect the "S" sender terminal to gauge signal input (Pin 3, Connector 3). Connect the "-" sender terminal to a common ground.

Make sure that the gauge and sending unit have a good common ground, i.e. ground the gauge and sending unit at the same location.

Use Teflon sealing compound on temperature and pressure sender threads as noted (*).

Test temperature and pressure sender connections for leaks. If a leak is detected, determine the cause of the leak and repair. DO NOT operate the vehicle if a leak is detected.

Fuel Level Gauge Calibration

Before installing the 5-in-1 fuel level gauge you may need to calibrate it to match your fuel level sending unit. The gauge factory default calibration setting is 0-90 Ohms (Empty-Full). The 5 available programmable input ranges are shown in Table 1 below.

To change the calibration setting:

1. To access calibration mode, turn the power to the gauge on with the CAL wire grounded. **The CAL wire is the GREEN wire on Pin 3 of Connector 2 (see Fig 1).**
2. The pointer will stop at 50% scale (2/4) to indicate you have successfully accessed calibration mode.

Table 1. Fuel Level Gauge Calibration Settings

Typical Application	Sender Output , Ohms (Empty-Full)	CAL Pointer Position
Most GM Vehicles After 1965	0-90	1/8
Universal	240-33	1/4
Most Ford & Chrysler Vehicles	73-10	3/8
Most GM Vehicles Before 1965	0-30	5/8
Most Ford Vehicles After 1986	20-150	3/4

Programming Full Dial Low Warning (WARN LO)

This gauge can be configured to show a full dial low warning (flashing amber backlight) when the gauge goes BELOW a specific value (i.e. volts goes below 10V).

1. To access WARN LO programming mode, press and hold the MENU button until the pointer moves to 25% scale (approx 1 second). Release the MENU button after the pointer has reached 25% scale.
2. After releasing the MENU button the pointer will move to the current low warning set point. Factory default is 0% scale (WARN LO deactivated).
3. To change the set point, press the MENU button repeatedly to move the pointer by 2% increments. Once the pointer reaches 100% scale, pressing the MENU button will decrease the pointer position by 2% increments.
4. Once the pointer indicates your desired low warning set point leave the MENU button untouched for 5 seconds. The low warning set point will be saved and the gauge will return to normal operating mode.

To turn the low warning OFF, repeat steps 1-4 above and change the low warning set point to 0% or 2% scale. Setting the low warning set point to 0% or 2% deactivates the low warning feature.

Viewing and Clearing Peak Value (RECALL)

1. To view the peak value, press the MENU button one time.
2. To exit RECALL mode press the MENU button one time.
3. To clear the stored peak value press and hold the MENU button for 3 seconds while in RECALL mode.

External Warning Output

This gauge features an external output that can be used to activate and deactivate warning lights or other vehicle systems such as fans, heaters, and pumps.

When a high or low warning condition exists the gauge outputs a 12V+ DC signal (500mA) on Pin 1 of Connector #1 (See Fig 1). The output is 0V when a high or low warning condition does not exist.

Do not install Connector 1 if external warning output is not required.

Fuel Level Gauge Calibration (Cont.)

3. Once the pointer stops at 50% scale (2/4) remove the CAL wire from the ground source. The pointer will move to indicate the current calibration setting per Table 1 below.
4. To change the calibration setting, momentarily ground the CAL wire. Each time you momentarily ground the CAL wire the calibration setting will change.
5. When the desired calibration setting is obtained (i.e. 73-10), leave the CAL wire ungrounded for 5 seconds. The gauge will save the new calibration setting, exit calibration mode and return to normal operating mode.

Programming Full Dial High Warning (WARN HI)

This gauge can be configured to show a full dial high warning (flashing amber backlight) when the gauge goes ABOVE a specific value (i.e. volts goes above 15V).

1. To access WARN HI programming mode, press and hold the remote button until the pointer moves to 75% scale (approx 3 seconds). Note: the pointer will stop at 25% scale for approx 1 second (for WARN LO programming mode), continue holding the button until the pointer has reached 75% scale. Release the button after pointer has reached 75% scale.
2. After releasing the button the pointer will move to the current high warning set point. Factory default is 100% scale (WARN HI deactivated).
3. To change the set point, press the MENU button repeatedly to move the pointer by 2% increments. Once the pointer reaches 0% scale, pressing the MENU button will increase the pointer position by 2% increments.
4. Once the pointer indicates your desired high warning set point leave the MENU button untouched for 5 seconds. The high warning set point will be saved and the gauge will return to normal operating mode.

To turn the high warning OFF, repeat steps 1-4 above and change the high warning set point to 98% or 100% scale. Setting the high warning set point to 98% or 100% deactivates the high warning feature.

Full Dial Warning (ON/OFF)

If desired, the full dial warning can be turned OFF so that only the External Warning Output activates when a high or low warning condition exists. To turn Full Dial Warning OFF (or ON):

1. Press and hold the MENU button until the pointer moves to 100% scale (approx 4 seconds). Note: the pointer will stop at 25% scale for approx 1 second, then 75% for approx. 1 second. Do not release the MENU button until the pointer has reached 100% scale. Release the button after the pointer reaches 100% scale.
2. After releasing the button the gauge backlighting will indicate whether Full Dial Warning is currently ON or OFF. Gauge backlighting will flash amber to indicate Full Dial Warning Mode is ON. Gauge will remain unlit to indicate Full Dial Warning Mode is OFF.
3. Press the remote button to switch between Full Dial Warning ON (flashing amber backlight) and OFF (no backlighting).
4. To save your changes, leave the MENU button untouched for 5 seconds. Full Dial Warning Mode (ON or OFF) will be saved and the gauge will return to normal operating mode.