

## FULL SIZE CHEVY STOCK HEIGHT DISC BRAKE KIT INSTRUCTIONS



\* High performance kit shown. Regular kit has plain rotors & hoses.

### **WARNING**

Proper operation of your brakes is essential for your safety and the safety of others. Any brake service should be performed **ONLY** by persons experienced in the installation and proper operation of brake systems. It is the responsibility of the person installing any brake component or kit to determine the suitability of the component or kit for the particular application. After installation and before operating your vehicle, be sure to test the function of the brakes under controlled conditions. **DO NOT DRIVE WITH UNTESTED BRAKES!**

### **IMPORTANT**

Take time to read all the literature that came with this kit. Check the provided list of parts against what you received to ensure all parts are present. While this kit was designed to make the process of changing brake parts as simple as possible. **NOTE: WITH SOME KITS IT MAY BE NECESSARY TO MAKE MINOR CHANGES TO YOUR CAR! READ ALL WARRANTY DISCLAIMERS AND RETURN POLICIES INCLUDED IN THIS KIT PRIOR TO INSTALLATION!**

### **NOTE:**

Before operating the vehicle after installation, test the function of the brakes under controlled conditions. Make several stops in a safe area from low speed and gradually work up to normal speeds. **DO NOT DRIVE WITH UNTESTED BRAKES!** Always utilize safety restraints when operating the vehicle. The installation of disc brakes will require the use of 15" wheels. Any attempt to install disc brake with a 14" wheel will be the customer's responsibility.

## Disc Brake Kit Identification Sheet



Part #: PB8531  
8" Dual Booster



Part #:  
CB5558  
CBS5558  
1955-58  
Caliper Brackets



Part #: MC1321H  
1' Bore MC



Part #:  
CB5964  
CBS5964  
1959-64  
Caliper Brackets



Part #: APV1  
Adjustable  
Proportioning  
Valve



Part #: 651A  
Booster Brackets



Part #: VH (2ft.)  
Check Valve Hose



Part #: HWK5558  
Hardware kit



Part #: 5514  
Stock Rotors



Part #: PRE5564  
Pedal Rod Ext.  
Part #: 6772-18  
Clevis  
Part #: 3717  
Dust Boot

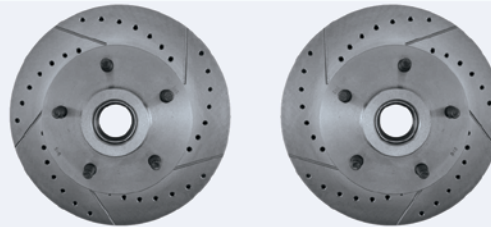

Part #: 5514LX/RX  
Stock HP Rotors



Part #: A6 Inner  
Bearings  
Part #: A2 Outer  
Bearings  
Part #: 7934  
Seals



Part #:  
HSDBK-SS-7/16  
Stainless Hoses



Part #:  
HSDBK-7/16  
Caliper Hoses



Part #: 20618101  
Dust Caps



Part #: 2-5557  
Castle Nut



Part #: 3966151-Bolt  
Spindle Nuts



Part #:  
4039 (right)  
4040 (left)  
Calipers  
Uses D52 pads

**PREPARING YOUR VEHICLE TO INSTALL YOUR BRAKE SYSTEM UPGRADE**

1. Rack the vehicle.
2. If you don't have a rack, then you must take extra safety precautions.
3. Choose a firmly packed and level ground to jack up the vehicle.
4. Chock the rear wheels.
5. Jack the vehicle up and support it with jack stands and secure the pins.
6. Set the parking brake and put the transmission in park if automatic, reverse if manual transmission.
7. The front wheels should be allowed to free hang to relieve tension on the coil springs.

**Remember: NEVER rely on jacks to support a vehicle! Always test the steadiness of your stands that are supporting the vehicle before attempting to work on a raised vehicle!**

**PREPARING YOUR PARTS**

1. Locate the spindles and the inner wheel bearings. In order to install the inner bearings on new spindles, often you must remove .0004" from the inner bearing seating diameter. This can be accomplished with 240 grit emery paper and a rotary sanding motion on the spindle. Be sure to sand around the radius of the spindle which avoids flat spots. Continue this operation until the inner bearings can be slid onto the spindle without binding. Remember to use brake parts cleaner to keep all surfaces free of debris. Also use a lubricant such as bearing grease to ease them on. Do not grind or file on the spindle!
2. Pack all bearings with hi-temp wheel bearing grease. A bearing packing tool is ideal for the job. (See Figure 1)
3. Adhere the brake pads into place using disc brake quiet and bend outer brake tabs over calipers accordingly. Let them cure!
4. Mate up each threaded nut with its' designated bolt or threaded surface.
5. Group your kit parts to speed up the installation.
6. Check your quantity of components versus the items list.



**COMPONENTS TO INSPECT, REPLACE OR UPGRADE PRIOR TO AND / OR DURING INSTALLATION OF DISC CONVERSION KITS**

Tie rod ends and nuts	Adjustment sleeves	Control arm shafts, mounting bolts, & nuts
Control Arms	Idler arm and nut	Pitman Arm and nut
Upper Ball Joints and nuts	Lower Ball Joints and nuts	Shocks and hardware
Residual valves	Metering valves	Proportioning valves
Brake lines	Stainless steel brake lines	Stainless steel hardware

# Installation Instructions for PART # 630080; 630085; 630095; 630096

## **SUGGESTIONS:**

- » Take the time to identify any suspect parts that are not included in this kit.
- » Consider making upgrades such as converting to polyurethane bushings, performance shocks, tubular a-arms, etc.
- » Plan any Installation (s) of replacement parts during the various stages of the drum to disc conversion process.

## **INSTALLATION OF THE DISC BRAKE KIT WILL REQUIRE THE USE OF THE FOLLOWING TOOLS & CHEMICALS:**

Most Tools Available at <a href="http://www.Jegs.com">www.Jegs.com</a> part numbers referenced below.			
Wheel bearing seal driver	Drum brake tool	Flare wrench set	Wheel chocks
3/8" ratchet drive set 555-W38911	3/8" Allen wrench or socket 555-80710	Jack stands 555-80036	Brake spring pliers 555-W175
Box end wrench set 555-W30630	Ball joint fork 555-80622	Tire iron 555-80581 / 555-80582	Brake bleeder wrench 555-80660 / 555-80661
Pliers 555-W30715	Screwdriver 555-W80007	Snips 555-80577	Grease gun 555-W54204
Universal Bearing Packer 555-W1218	Line bending tool 555-80086	Disc brake quiet	Wheel bearing grease
Ball pein hammer	Disc brake pad spreader tool	Brake Fluid	Brake cleaner
Caliper slide grease	Hand cleaner		

## **INSTRUCTIONS**

1. Remove the stock Chevy front drums, brakes and backing plates. Clean and inspect the spindles for cracks or damage. Be sure to thoroughly clean out the 5/8" threaded hole at the top of the spindle. This is extremely important. Use a non oil based cleaner such as Brake Clean. Clean the threads out with a bottoming tap if necessary.
2. In order to install the inner bearing on some spindles, you must remove .0004" from the inner bearing seating diameter. This can be accomplished with 240 grit emery paper and a rotary sanding motion on the spindle. This operation must be continued until the inner bearing can be slid onto the spindle without binding. Do not try grinding or filing the spindle. It only takes a few minutes with emery paper.
3. Once the bearings have been fitted to the-spindle, take the small support bracket (See Figure 2) and install it on the outer surface of the spindle in the two lower holes. Install the shorter 7/16-20 bolt (2 1/4") in a similar manner through the front hole. Install the locknuts supplied in the kit and tighten.
4. Take the appropriate caliper bracket (LH or RH as marked on the inside of the bracket) and install it as per figure 2. Install the 1/2" x 2 1/2" bolt and support bracket as shown. Install the 1/2" locknut but do not tighten it yet, just snug it up.
5. Take the 5/8 x 1" bolt and install it through the bracket into the spindle. Do not tighten it yet, just snug it up.
6. Take the rotor, clean it and inspect as necessary. Install the inner bearing with grease followed by the 7934 S seal.
7. Install the rotor on the spindle followed by the outer bearing. Put the bearing retaining washer and nut-on the spindle to hold everything in place temporarily.



FIGURE 2

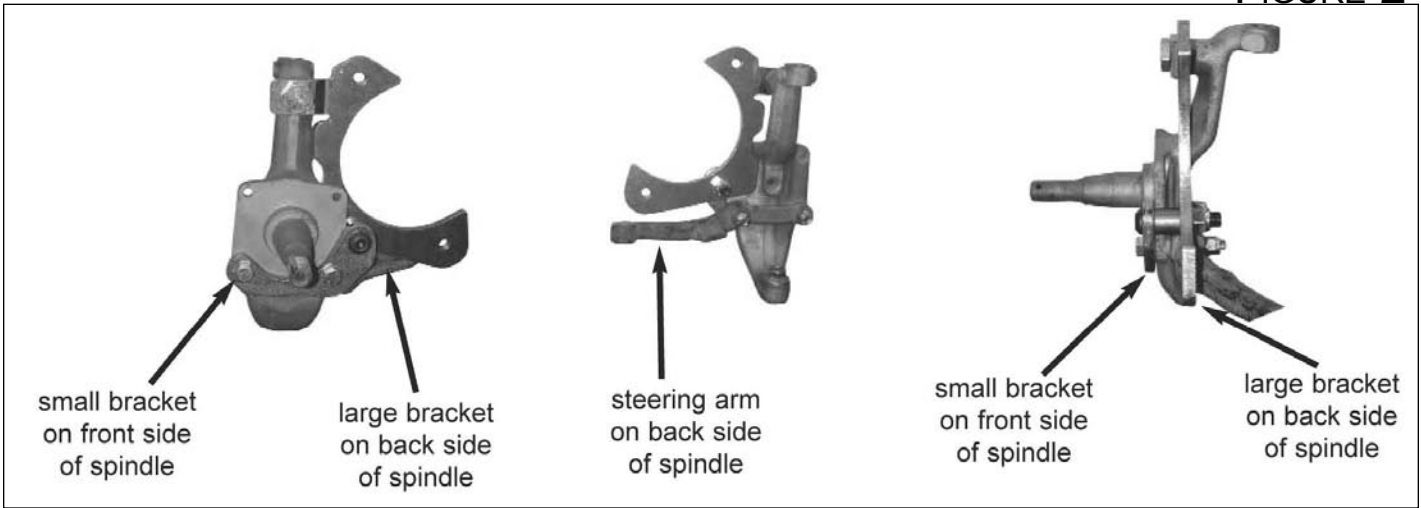

- 8. Turn the rotor on the spindle and check for any interference or minimal clearance between the inside surface of the rotor and the attaching hardware.
- 9. When you have adequate clearance, make sure the threads in the spindle are clean. Install the bolt, tighten it and the 1/2" bolt previously installed.

FIGURE 3

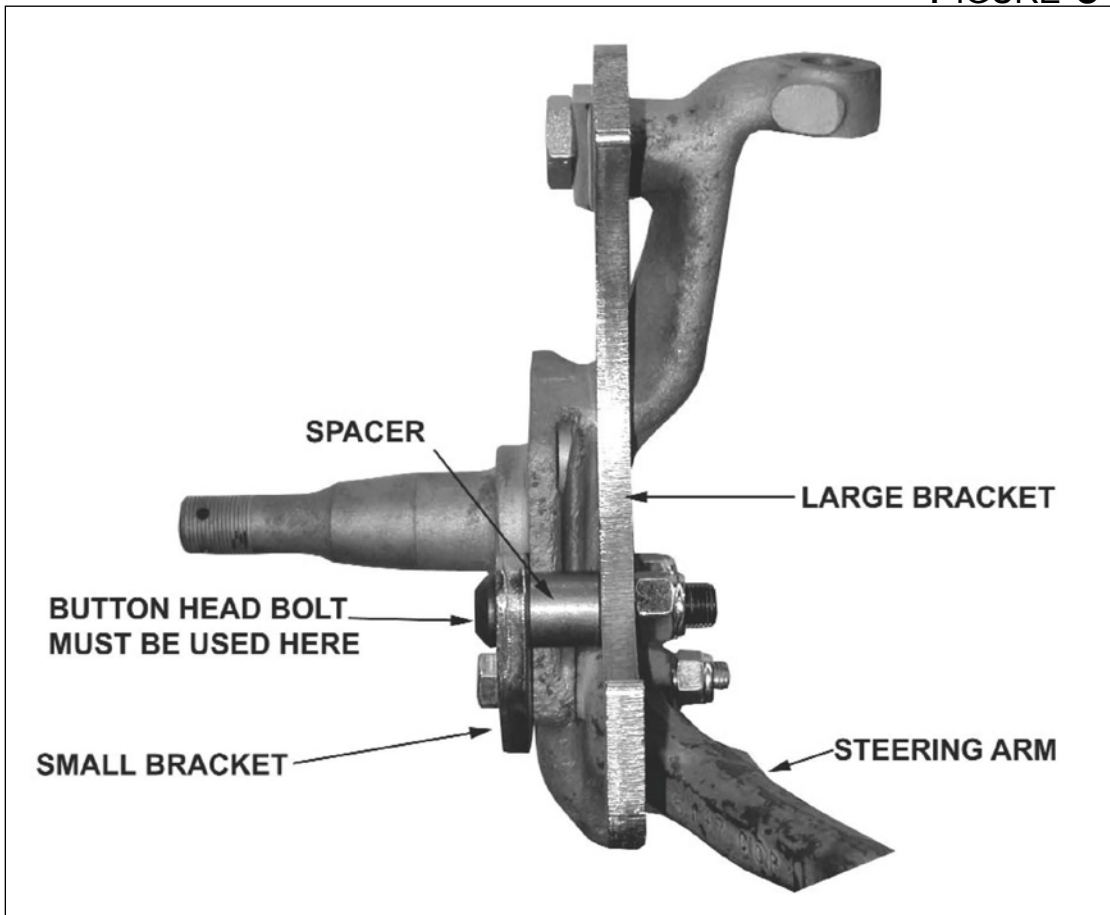
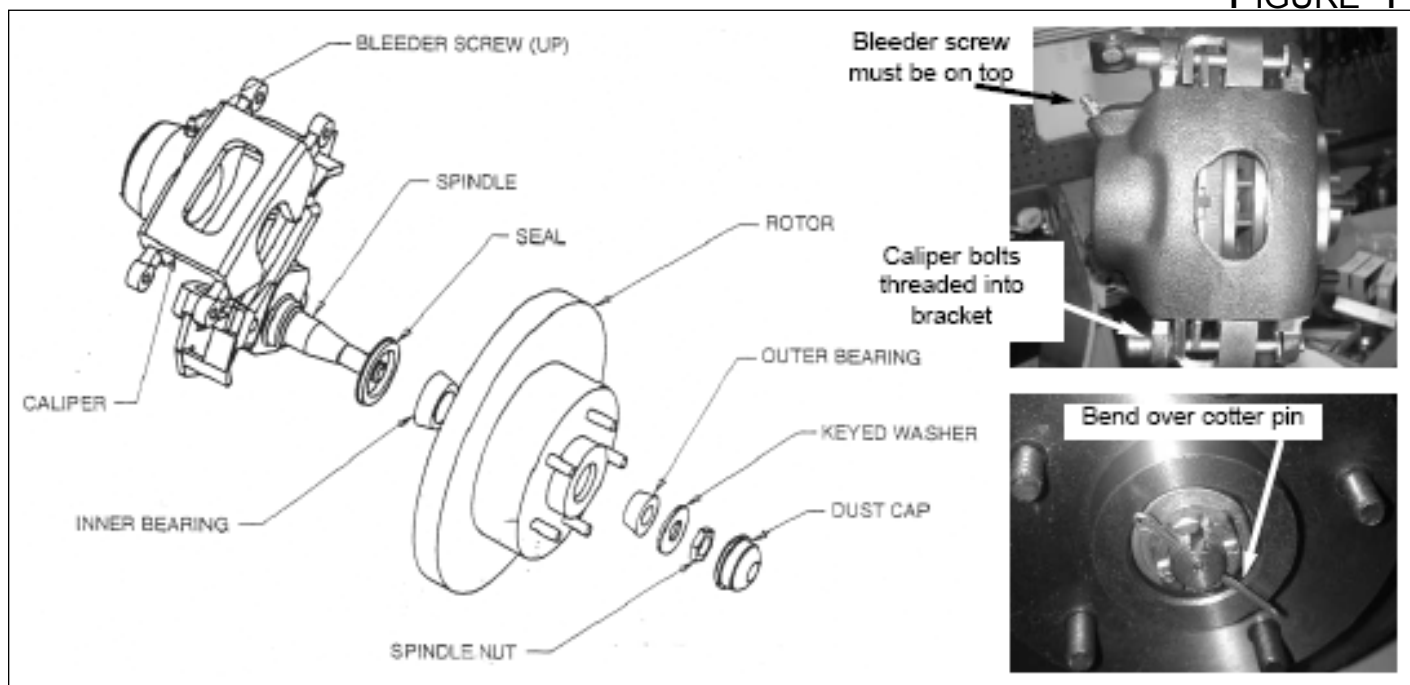

FIGURE 4



10. Re-check all the bolts for tightness and re-install the rotor and outer bearing. Install the new bearing retainer washer followed by the special wheel bearing retaining nut supplied in the kit. Do not attempt to use the stock bearing- nut, the cotter pin hole will not line up. Adjust the wheel bearings and install the cotter pin. Check for clearance and freedom of movement once more.
11. Install the caliper on the bracket (remember there is a left hand and right hand caliper) using the standard GM caliper mounting belts. Tighten bolts to recommended GM torque specifications. **BLEEDER SCREWS MUST FACE UP ON THE CALIPERS** (See Figure 4).
12. Repeat the procedure for the opposite side.
13. Connect the calipers to the brake lines using the supplied hoses.

## **MASTER CYLINDER / POWER BOOSTER INSTALLATION**

1. Disconnect the old master cylinder lines (Remember, if operating around painted surfaces, avoid brake fluid to paint contact). Remove any valves that are installed in the drum system and discard. If the vehicle has a pressure differential switch, it must also be removed. Remove the old master cylinder.
2. When changing from a manual brake system to a power system, the clevis assembly that attaches the push rod to the brake pedal must be removed and lowered one inch. If two holes are in the pedal use the lower hole for the power booster rod attachment. If only one hole exists from the manual system a second hole must be drilled one inch lower. Remove the clip and pin that attaches the clevis to the brake pedal and retain them. If the lower hole does not already exist, one must be drilled. Screw the clevis assembly onto the new push rod on the booster about 1/2".

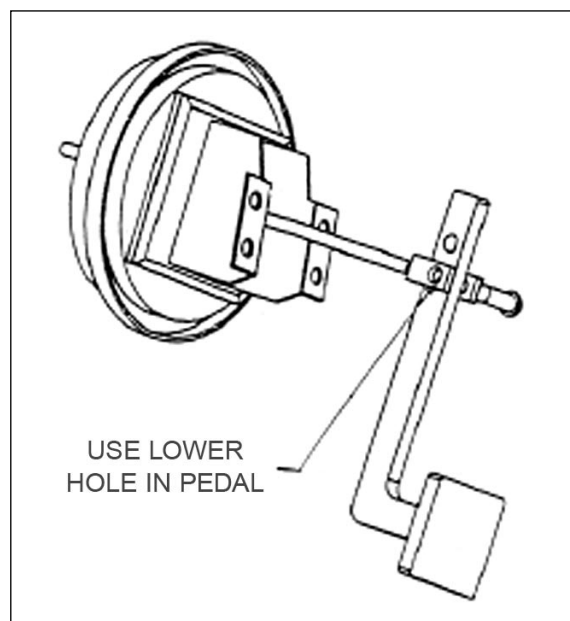

## Installation Instructions for PART # 630080; 630085; 630095; 630096

3. Mount the booster to the fire-wall with the existing studs or bolts. Place the clevis assembly into the lower hole in the pedal and install the pin and clip.
4. Install the proper fitting into the intake manifold for vacuum. Connect the vacuum hose from the engine to the power booster. YOU WILL NEED AT LEAST 18" VACUUM TO OPERATE A BOOSTER.
5. Bench bleed the master cylinder with the supplied bleeder kit.
6. Install the master cylinder onto the booster.
7. Flush out the old brake fluid and replace with DOT 4.
8. Bleed the entire system starting at the wheel farthest from the master cylinder. Check the pedal feel for firmness. Adjust the clevis so there is 1/4" free play at the pedal stop. If pedal is spongy, bleed again.

NOTE: If you are installing disc brakes without a power booster just mount the manual master to the fire-wall on the two studs that line up with the large hole. Attach the manual brake push rod to the pedal in the upper hole and adjust it so that it seats into the piston hole without applying pressure to the piston while at rest.

### **ADJUSTABLE PROPORTIONING VALVE**

Adjustable proportioning valves are essentially pressure reducing valves and are often utilized in disc/drum, disc / disc and drum / drum braking systems. The valve is used to control front-to-rear brake pressure bias and will work for all types of vehicles. Install this valve between the distribution block and the rear flex hose in the front-to rear rigid brake line. Always use tube wrenches to tighten fittings properly. Final settings of this valve will depend on your particular vehicle, and individual preference.

### **SPECIFICATIONS**

- "IN" (Stamped on valve) - Rigid brake line from the distribution block to this port. On early cars: the master cylinder rear port to this port.
- "OUT" (Stamped on valve) - Rigid brake line to the rear flex hose.
- "DECREASE" - Reduces the brake line pressure to the rear brakes.
- "INCREASE" - Increases the pressure to the rear brakes.

Maximum pressure regulation: 300 psi. Inlet port of valve: 1/8 - 27 NPT  
Standard adaptors: 3/8" - 24 for 3/16" line.  
Mounting hole diameter: .250" (two).



## **WHAT TO DO IF YOU SUSPECT YOUR BOOSTER IS NOT WORKING**

It is rare that one of our kits will contain a defective power booster but if you suspect that your booster is not functioning correctly perform the following tests:

### **BASIC TEST**

1. With the engine off depress and release the brake pedal several times to eliminate vacuum from the power section.
2. Depress the pedal and hold down with light pressure, 15 to 25 pounds.
3. Start engine.
4. If the power unit is operating the pedal will drop slightly. Less pressure will be needed to hold the pedal down.

## **IF BOOSTER IS NOT OPERATING (GIVING A VERY HARD PEDAL)**

1. Disconnect the vacuum hose from the booster check valve and check the vacuum level at this point with the engine running with a vacuum gauge. You should have at least 18" vacuum to the booster. Anything lower will begin to give a hard pedal. If the vacuum level is below 18" you may be able to tune the engine and bring the vacuum level up to that level. If the vacuum level is around 16" the addition of a vacuum reserve canister will improve the braking. If the vacuum level is below 16" you will need to add an electric vacuum assist pump to supplement the engine vacuum.
2. If the vacuum level at the check valve is 18" check that the booster check valve is working. Disconnect the vacuum hose at the check valve and attach a piece of tubing. Blow into the valve. If air passes through the valve is defective and must be replaced. Also look into the hose attachment neck on the check valve and be sure there is no obstruction inside the valve.
3. Check your booster for a vacuum leak. With everything hooked up run the engine at moderate speed. Release the accelerator and turn the engine off. Wait 90 seconds and apply the brakes. If the brake applications are power assisted there is no leak. If there is no power assist the booster is defective and must be replaced.

## **IF THE BOOSTER IS OPERATING BUT YOU STILL HAVE A HARD PEDAL**

1. Your combination valve may have tripped shutting off fluid flow to the front or rear brakes. This condition will produce a very hard pedal. Check that fluid passes through the valve to both the front and rear by cracking a bleeder screw and observing a good flow of fluid. If one half of the system does not have flow, re-center the valve.
2. You may have frozen rear wheel cylinders or frozen caliper pistons. If these components freeze you can get a very hard pedal.
3. Your pedal ratio may be too low. Check your pedal ratio. The pedal ratio must be in between 4:1 to 5:1. Some of the older cars that had power brakes used a ratio of almost 1:1. If you add a vacuum booster to this type of car you will have a very hard pedal. Typically we are talking about late 50's cars. Adjust ratio as necessary.
4. Your booster may be undersized for the weight of the vehicle or the bore size of the master. If you try to use a small diameter booster such as a 7" street rod booster for a heavy car you will get a very hard pedal. Compounding the problem is an attempt to use a large bore master (1-1/4" or larger) on a small booster.

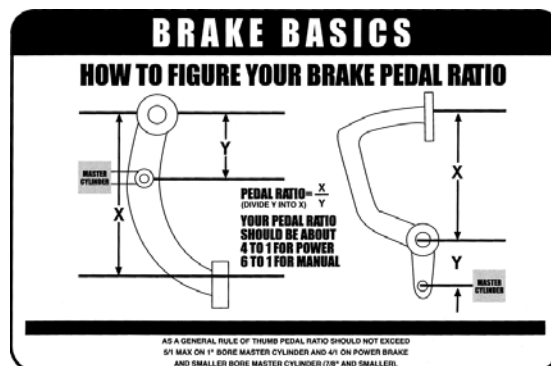

## **IF YOUR BRAKE PEDAL IS VERY SENSITIVE AND THE BRAKES GRAB**

1. Your pedal ratio may be too high. Power brakes will require a 4:1 to 5:1 ratio. If your ratio is around 6:1 you are getting too much mechanical advantage making the brakes extremely sensitive. Adjust the ratio to correct level.
2. The booster may be too large for the weight of the vehicle. Lightweight vehicles with large boosters give you "touchy brakes". This effect may be dampened somewhat by going to a larger bore master.
3. Too large a booster for front drum brakes. Drum brakes do not require as much pressure as disc brakes (500 psi vs. 1,000 psi). If your booster is very large (11") and you have drum brakes you are over-boosted. Do a pressure test to determine what you have.
4. The booster has a cracked internal hub. When there is a crack in the phenolic hub inside the booster it will be either totally on or totally off. Any slight pressure to the pedal will cause the brakes to lock up. The booster must be replaced.

## TEN REASONS FOR A POOR BRAKE PEDAL

CAUSE	REASON
Bleeder screws on calipers not on top.	The bleeder screws on calipers must be at the 12:00 position on the caliper to allow all the air to escape during bleeding. A very common mistake installers will make is to reverse the side the caliper goes on giving you a situation where the caliper bleeder screw is facing down. It's also common to use the wrong caliper on a bolt on disc kit giving a situation where the bleeder hole is shifted from the 12:00 position producing a pocket of air at the top of the caliper bore which can not be dislodged. Check your bleeder hole orientation.
A defective master cylinder which does not hold pressure.	If brake fluid bypasses a pressure seal on a master cylinder you will get a pedal that fades. To test for this obtain two inverted flare plugs at an auto parts store and plug both master cylinder outlets. Try your pedal. If the pedal is high and firm the master is good. If the pedal fades the master is bad. Replace master as necessary.
No residual pressure valve to rear drums.	Drum brakes require the use of a 10 lb residual pressure valve in the line. This residual pressure counter balances the drum brake spring tension keeping the shoes close to the drums. This results in a higher firmer pedal. You can test this by clamping off the rear hose removing the rear drums from the system. Now test your pedal. If the pedal gets better you will need to splice a 10 lb residual pressure valve into the rear line.
Hard line that loops up.	Hard brake line that loops up and then back down will tend to trap air. It doesn't take much air to cause problems so check your lines carefully.
Incorrect master cylinder.	If the bore size of the master cylinder is too small for the fluid requirements of the system you will get a very poor pedal. This will happen most frequently with four piston calipers and with four wheel disc brakes. The only solution for this is to install a larger bore master cylinder or a true four wheel disc master.
Incorrectly bled or adjusted rear calipers.	Rear calipers that have an internal parking brake with a lever can be troublesome. These calipers must be adjusted so that the piston is moved out and the pads are close to the rotor. If this initial adjustment is not made the pistons will travel outward during activation but no squeezing of the rotor will occur. This can be checked by clamping off the rear hoses and checking if the pedal gets better. Adjust as necessary.
Incorrect booster pin length.	The booster pin that pushes on the master cylinder must almost be touching the master cylinder piston face. A gap larger than 1/32" will begin to introduce a spongy pedal. Adjust as necessary.
Silicone brake fluid.	While silicone fluid is great because it does not attack paint it also aerates very easily and can give a spongy pedal.
Rear wheel cylinders too large.	Rear drum wheel cylinders that are too large will give a poor pedal. Check as in step six above.
Loose front wheel bearings.	Loose front wheel bearings will cause rotor wobble. This will cause the caliper pistons to retract too far into the caliper giving a spongy pedal every time you hit the brakes. Check and adjust as necessary.

### **UNIVERSAL FRONT DISC BRAKE CHECKLIST**

- [ ] 1. Spindle properly secured to ball joints and tie rods with castle nut and cotter pin.
- [ ] 2. All mounting bolts properly tightened.
- [ ] 3. Wheel bearings properly packed with grease.
- [ ] 4. Inner bearing must be installed before grease seal.
- [ ] 5. Rotor I bearings slide onto spindle with ease.
- [ ] 6. Washer, castle nut properly torqued and cotter pin installed.
- [ ] 7. Calipers installed and properly torqued.
- [ ] 8. Spin rotor and check for any interference. (If any interference is found, resolve problem before driving vehicle.)
- [ ] 9. Flex lines are properly installed with no interference.
- [ ] 10. Power booster (if applicable) installed properly.
- [ ] 11. Master cylinder bench bled according to the instructions.
- [ ] 12. All brake lines are properly tightened and free of leaks.
- [ ] 13. Turn wheels lock to lock and check for any interference.
- [ ] 14. Place wheel onto vehicle and spin the wheel to make sure there is no interference between the brakes and wheel.

### **UNIVERSAL REAR DISC BRAKE CHECKLIST**

- [ ] 1. All bolts on base bracket properly tightened.
- [ ] 2. All caliper mounting bolts properly tightened.
- [ ] 3. Rotor slides onto axle with ease.
- [ ] 4. No interference with rotor and any other parts (splash shield, brackets, etc.).
- [ ] 5. Caliper is centered over the rotor (because of difference in axle lengths, you may have to shim caliper in or out).
- [ ] 6. No interference with caliper and rotor.
- [ ] 7. All brake lines are tight with no leaks.
- [ ] 8. Parking brake is properly adjusted and not dragging, with vehicle on ground.
- [ ] 9. Adjustable proportioning valve installed (if applicable).
- [ ] 10. Distribution block modification made (if applicable).
- [ ] 11. Brake system properly bled.

WITH EVERY NEW SET OF ROTORS AND PADS, YOU SHOULD GIVE YOUR VEHICLE 200 - 250 MILES OF EASY DRIVING TO PROPERLY SEAT THE PADS TO THE ROTORS. DO NOT TAKE THE VEHICLE UP TO 60 MPH AND JAM ON THE BRAKES BEFORE THE FIRST 200 - 250 MILE BREAK IN PERIOD IS OVER, OR YOU WILL GLAZE THE PADS AND ROTORS.