

Installation Instructions for JEGS 2-Point Non-Retractable Seat Belts

WARNING! Proper installation of your seat belts is essential for your safety and the safety of others. Seatbelt installation should be performed **ONLY** by persons experienced in the installation and proper operation of these systems. It is the responsibility of the person installing any safety component or kit to determine the suitability of the component or kit for the particular application.

DO NOT attach this seat belt to a seat assembly, attach only to metal areas of the vehicles body.

WARNING! Check for any kind of interference from brake lines, wiring, exhaust or any other obstructions before drilling. Examine the body/floor pan for rust and corrosion; reinforce area around holes before installing the hardware.

Mounting Instructions:

- If the vehicle is equipped with pre-threaded seatbelt fastening holes and the seat is mounted in the original location. Attach the angle brackets to these holes as shown in Figure 1 below.
- If the vehicle is not equipped with any holes, slide the seat back as far as possible, position the holes about 2" rearward of the back edge of the seat and about 14" to 20" apart (see Figure 2). Drill holes through the floor pan; attach the angle brackets to the floor as shown in Figure 3. Be sure to mount the reinforce washer and lock washer on the underside of the floor, tighten the mounting bolt and nut while aligning the angle bracket to it's desired direction.

Check seat belt webbing, mounting and buckles periodically to insure safety.

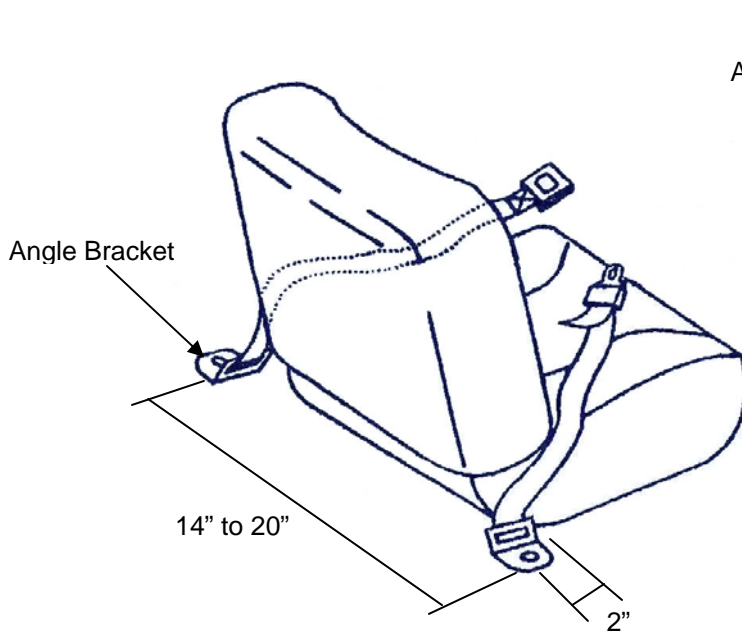

Figure 2

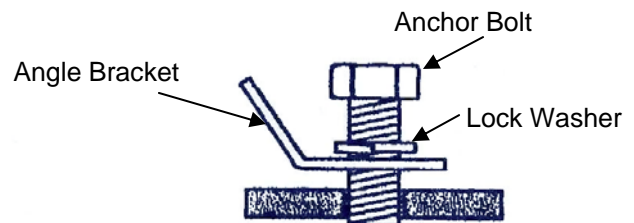

Figure 1

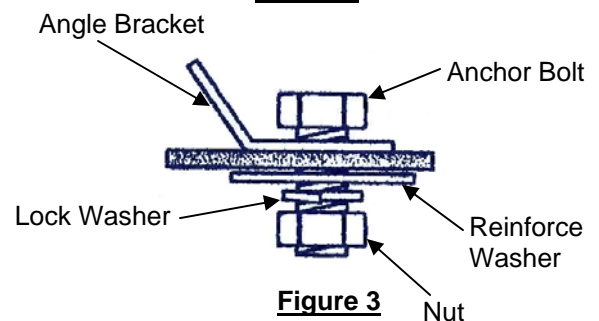

Figure 3