

## ***Installation Instructions for 70220 Sliding Seat Mount Instructions***

Note: Requires use of 70225 Stationary Pedestal Mount

### ***Kit Includes:***

- |                              |                         |
|------------------------------|-------------------------|
| 1) Slide Rail with Handle    | 12) 5/16" Lock Washers  |
| 1) Slide Rail without Handle | 8) 5/16" Threaded Nuts  |
| 1) Cross Wire                | 4) 5/16" x 1-1/2" Bolts |
| 4) Cone Washers              | 4) 3/8" x 1" Bolts      |
|                              | 4) 3/8" Lock Washers    |

***NOTE: DO NOT TIGHTEN ANY BOLTS UNTIL THE LAST STEP!***

1. Place slider brackets parallel to each other and position cross wire as shown in diagram.
2. With cross wire installed, place slider brackets on bottom of seat and align mounting holes.
3. Place cone washers between the slider brackets and seat. Thread the 5/16" x 1-1/2" bolts through the slider brackets and cone washers into the mounting inserts in the seat bottom.
4. Place the seat in the desired location in the vehicle and mark the location of the two front mounting studs.
5. Measure back 11" from the marks made for the front mounting studs and mark locations for the rear mounting studs.
6. Drill four 11/32" holes in the locations determined in steps 4 and 5.
7. Place the seat in the vehicle and position the 4 mounting studs on the slider bracket through the 4 holes drilled in step 6.
8. Thread the 5/16" nuts and lock washers to the mounting studs and secure the seat to the vehicle.

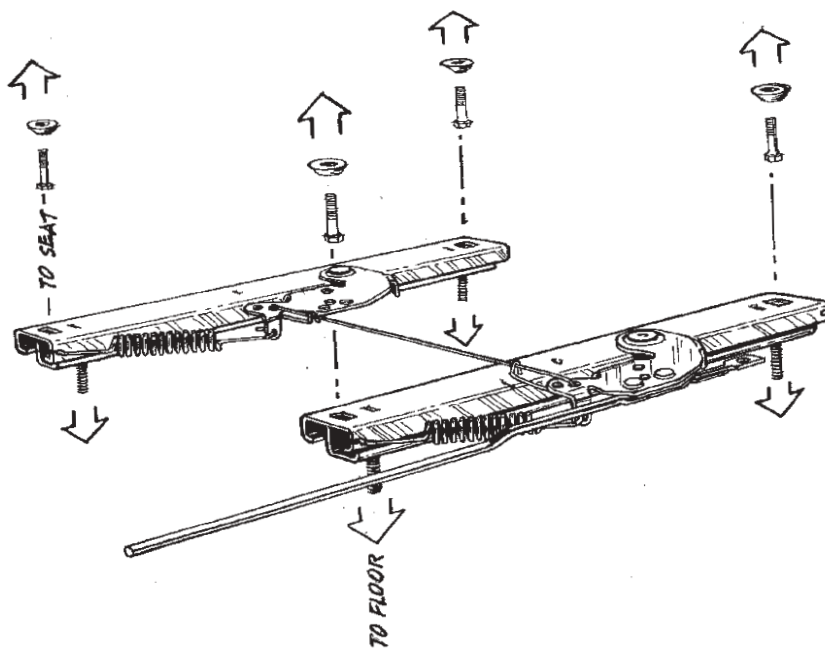

1-800-345-4545 [jegs.com](http://jegs.com)