

Installation Instructions for 81556 Tube & Pipe Notching Tool

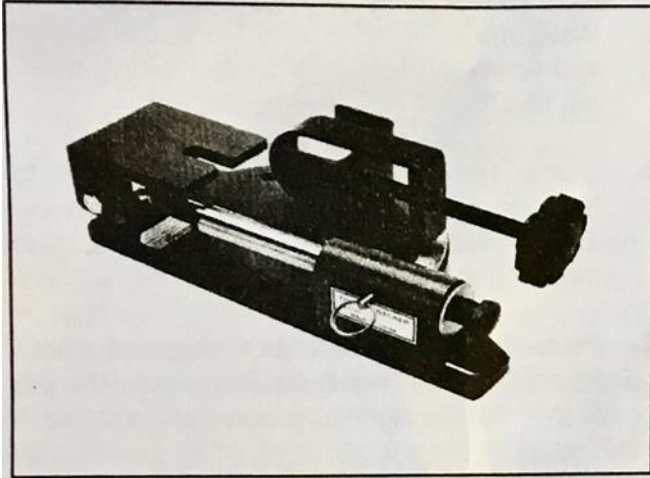

The Pipe/Tube Notching Tool is designed to notch pipe and tubing at angles ranging from 45° to 90°, and handle a round workpiece from 3/4" to 2 1/8" outside diameter (O.D.) using your drill press, mill or hand drill. The stroke of the spindle is 3 3/4" and accepts hole saws that are threaded for 1/2" and 5/8" mounting holes. A degree scale, workpiece clamp and adjustable mounting base round out the items that come with your new notching tool. The notching tool comes from the factory packed in the box with the spindle inverted. Before use, the spindle will need to be removed and turned around, as described below.

1. Pull the pin as shown in **Figure 1** and extract the spindle.
2. Remove the 5/8" adapter and washer from the spindle.
3. Insert the threaded end into the bracket.
4. Align the holes in the side of the spindle and bracket and insert the pin.

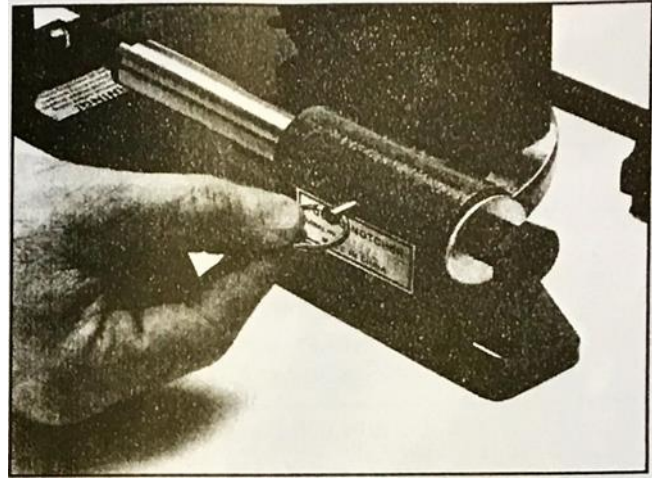

Figure 1. Pulling the pin

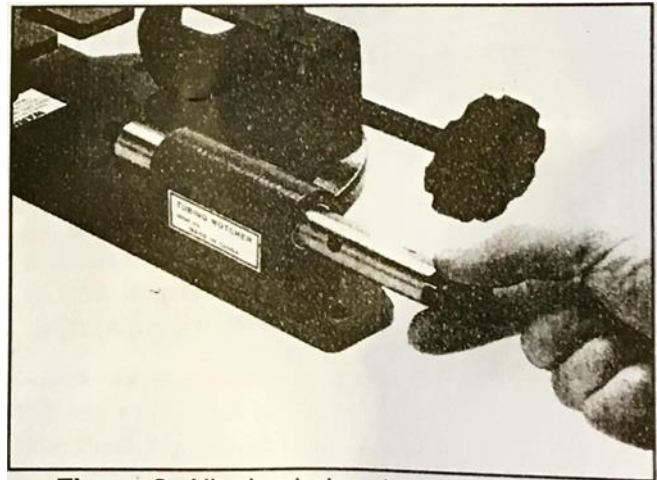

Figure 2. Aligning holes during assembly

Specifications

Maximum Tube Capacity: 2"

Maximum Hole Saw: 2-3/4"

Hole Saw Threads: 1/2"-20 & 5/8"-18

Spindle Stroke: 3-3/4"

The jig must be positioned squarely when used on a drill press. The base supports the jig with a bracket that is secured with 2 hex bolts, that when loosened, allow it to pivot in 2 directions. For now, loosen the bolt as in **Figure 3**, and rotate the base so it is roughly square to the jig and tighten the bolt.

WARNING

Read the drill press manual and be familiar with the drill press before using the pipe/tube notching tool. This manual is not a replacement for the drill press manual and is to be used in conjunction with it.

Hole saws are attached by threading them onto the jig spindle. In some setups it may be an advantage to remove the spindle support bracket to make it easier to change out or install a hole saw. To do this, do these steps:

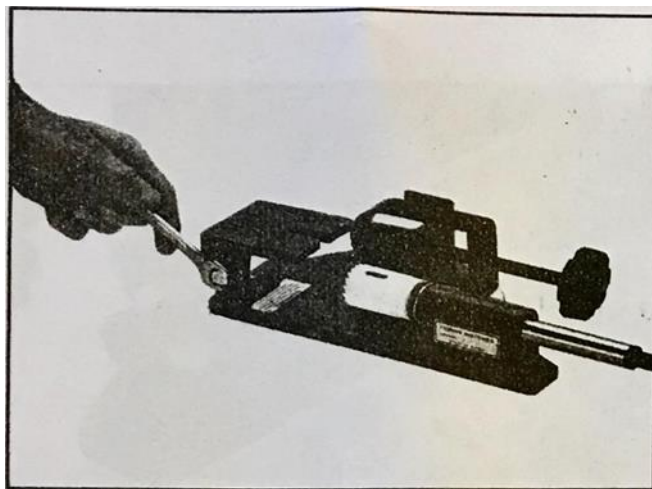

Figure 3. Square the base to the jig.

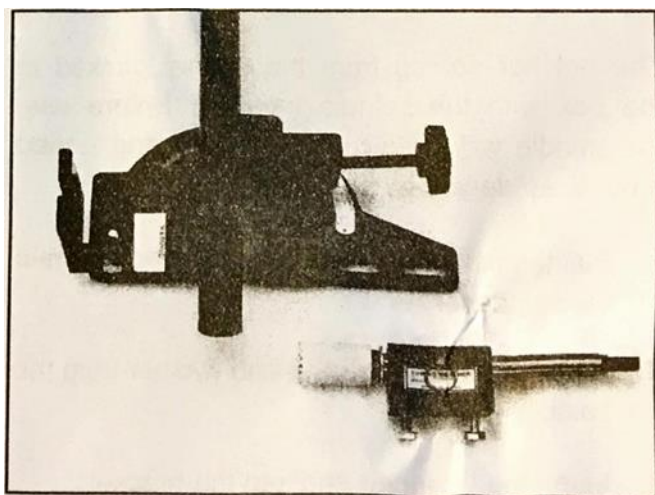

Figure 4. Ready to mount the hole saw

1. Remove the 2 hex bolts located on the back of the jig which secure the spindle support to the jig as in **Figure 4**.
2. Place the included washer onto the spindle and screw the hole saw on by hand. If needed, use the $\frac{5}{8}$ " thread adapter.
3. Use a 16mm or adjustable end wrench to hold the spindle and tighten the hole saw. The pin will hold the spindle when the jig is mounted to a drill press or vise.
4. Place the bracket back on the jig and attach loosely with the hex bolts. Make sure the pin is inserted through the bracket and spindle.
5. Place a workpiece into the strap clamp as in **Figure 4**. Slide the bracket until the hole saw almost touches the workpiece. Tighten the hex bolts to secure the bracket.

Note: We recommend that the height of the bracket be adjusted so the hole saw is as close as it can be to the workpiece without touching. This will help minimize flex in the jig.

There are many ways to clamp the jig to a work table on the drill press. Ultimately, it is important to make sure that it is secure enough so it won't twist or come off of the table during use. We recommend that the jig be secured to the drill press work table at 2 points as in **Figure 4**. It is also important to verify that the spindle of your drill press is perpendicular to the worktable. Please see the manual that came with your drill press before proceeding further.

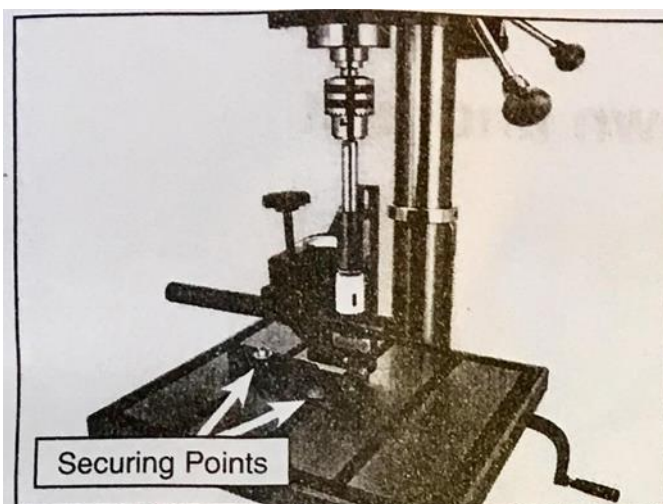

Figure 4. Mounting the jig to a drill press using a strap clamp in one location and a bolt with a t-nut in another location.

To setup the notching jig on the worktable of your drill press, do these steps:

1. Place the jig on the work table of the drill press, and lift or lower the table so that the top of the jigs spindle is $\frac{1}{2}$ " lower than the drill chuck. This should be done with the pin installed through the bracket and spindle.
2. Open the jaws to the drill chuck and lower it onto the jig spindle.
3. Loosen the 2 hex bolts that attach the base to the jig.
4. Locate the flats on the jig spindle and carefully align them with the jaws on the drill chuck. Tighten the jaws on the drill chuck. Failure to clamp the flats properly may result in the spindle coming loose in the drill chuck which will damage drill chuck and the flats.
5. Secure the base of the notching jig to the top of the drill press worktable with bolts, strap clamps or C-clamps.
6. Rotate the drill chuck by hand to test how easily the whole assembly turns. If it won't turn or, if it takes a lot of effort to turn it, find the reason. Use the following list to remedy this problem.
 - a) Double check that the spindle is square to the table.
 - b) Loosen the 2 hex bolts on the jig base and rotate the spindle. Tighten the hex bolts and test again. ■
 - c) Loosen the bolts/clamps that secure the base to the work table and turn the spindle. Retighten the bolts/clamps and test again.

Operation

For cutting steel pipe and tubing we recommend bi-metal hole saws. These can be operated at up to 500 RPM for most diameters and should be operated at higher speeds for thin wall tubing.

Before operating the notching tool, make sure that the jig is secure, the workpiece is clamped solidly and in the correct place, and that the drill chuck turns freely.

We recommend using cutting fluid to extend the life of the hole saw.

Before turning the drill press or hand drill ON, remove the pin from the spindle bracket and spindle.

During operation it is necessary to oil the spindle bushings. We recommend 10 wt. non-detergent oil. A few drops applied to the spindle shaft above the bushings before using the notching jig will be adequate but if the jig is to be used for long periods at a time oil should be applied several times per hour.



1-800-345-4545 jeps.com

Part Breakdown and List

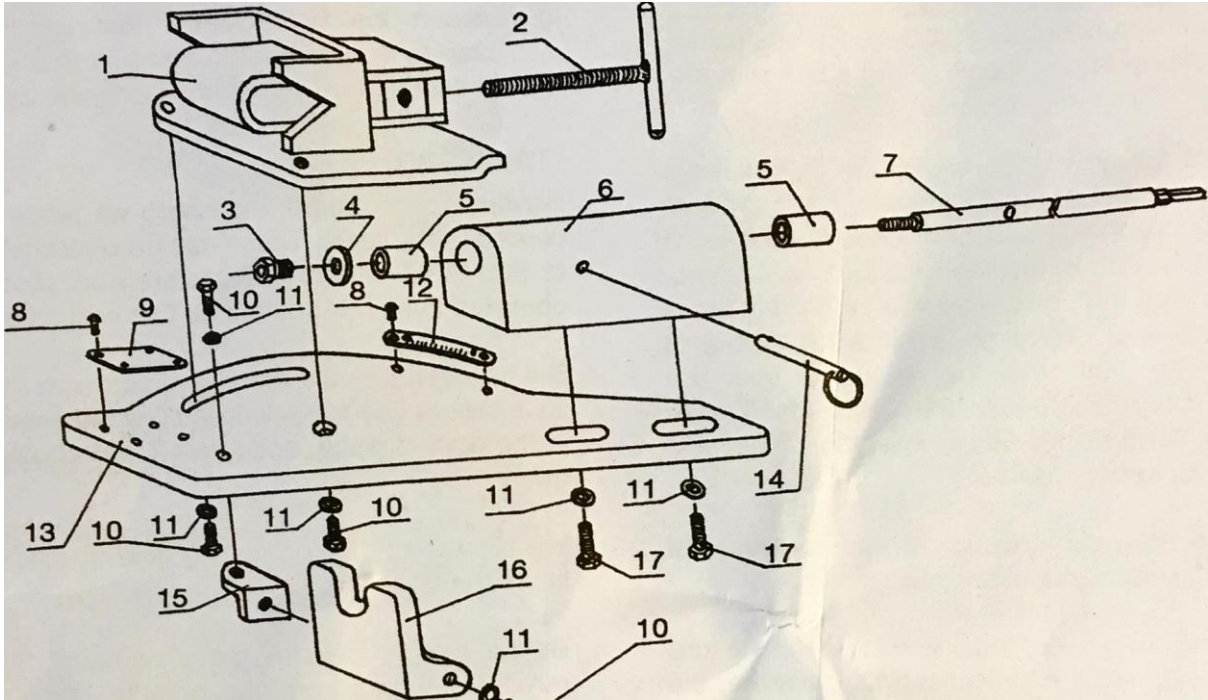

Ref #	Description	Ref #	Description
1	Clamp Assembly	10	Hex Bolt M8-1.25 x 20
2	Handle/Clamp Screw	11	Washer M8
3	5/8" Hole Saw Adapt	12	Angle Indicator
4	5/8" Hole Saw Washer	13	Body
5	Bushing	14	Locking Pin
6	Spindle Support	15	Adj. Plate
7	Spindle	16	Mounting Plate
8	Rivet	17	Hex Bolt M8-1.25 x 25
9	Label		