

# **User Guide for 86012**

## **Inverter Generator**

4500 Watt, Rated 3700 Watt

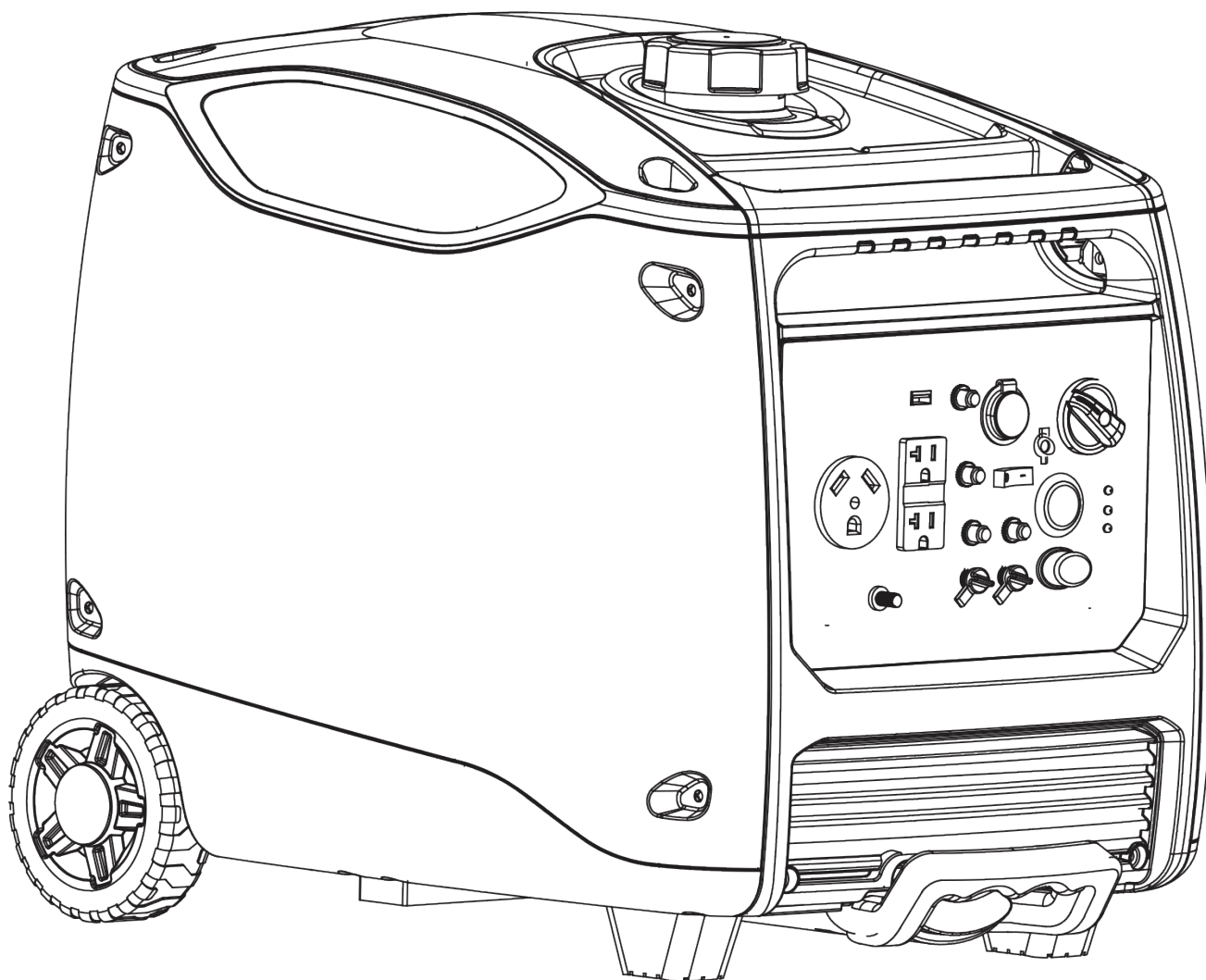

# Table of Contents

<b>Parts List</b> .....	2	<b>Operation</b> .....	12-17
<b>Introduction</b> .....	3	How to Start Engine.....	12
Product Specifications.....	3	How to Stop Engine.....	13
Customer Service .....	3	Pairing Remote Fob.....	13
<b>Safety Rules</b> .....	3-6	Attaching Electronic Devices.....	14
Safety Symbols.....	3	Charging a 12 Volt Battery.....	14
Safety Instructions.....	4-6	AC Parallel Operation.....	15
<b>Control Panel Functions</b> .....	7-9	Do Not Overload Generator.....	16
Fuel Valve Knob.....	7	Wattage Reference Guide.....	17
USB Power Outlet.....	7	<b>Maintenance</b> .....	18-21
Indicator Lights.....	7	Maintenance Schedule.....	18
DC Circuit Breaker.....	8	Checking Spark Plug.....	19
Engine “Economy” Control.....	8	Changing Oil.....	20
Parallel Connections.....	8	How to Clean Air Filter.....	20
Ground Terminal.....	9	Checking Muffler and Spark Arrestor.....	21
<b>Assembly</b> .....	10-11	How to Clean Fuel Filter.....	21
Connecting Generator to a.....	10	<b>Transport &amp; Storage</b> .....	22-23
Building electrical system		Draining Fuel.....	22
Adding Fuel.....	10	<b>Troubleshooting</b> .....	24
Battery Installation.....	11	<b>Wiring Diagram</b> .....	25
Adding / Checking Oil.....	11		

# Parts List

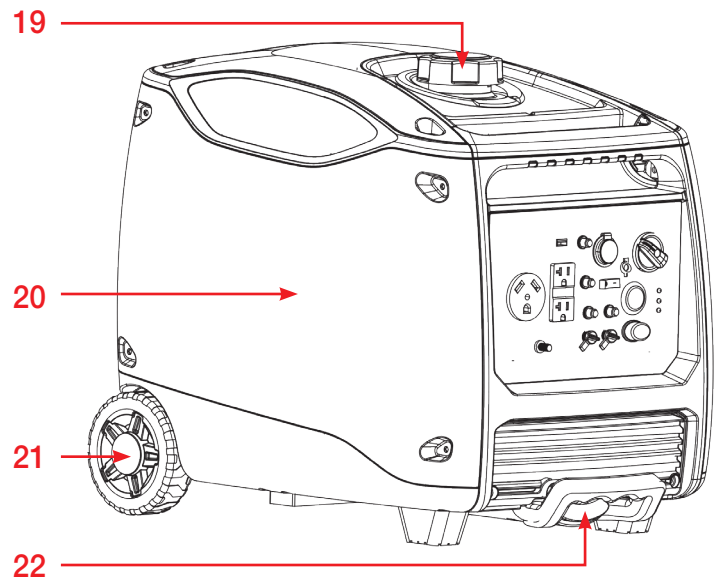
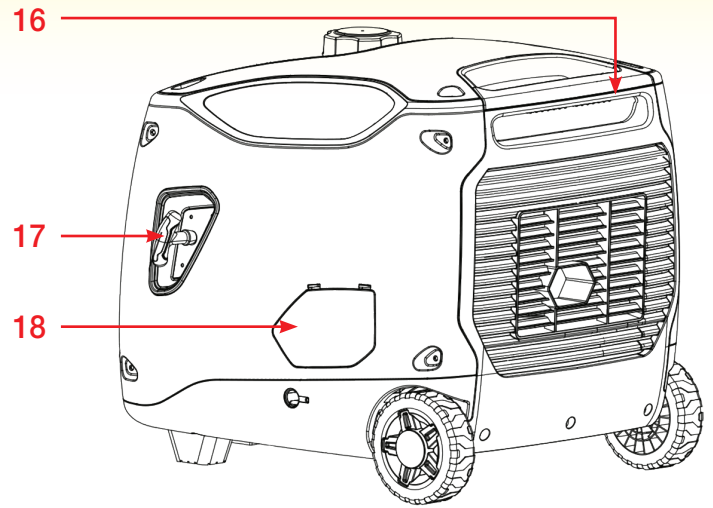
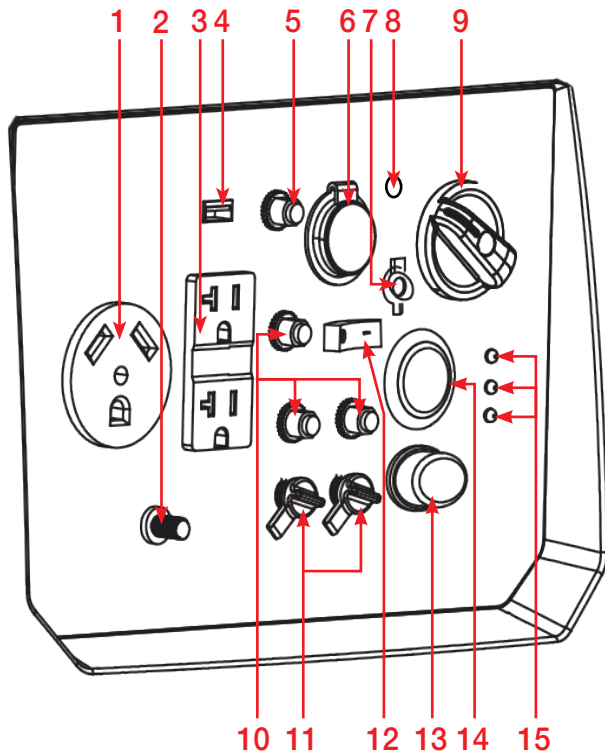

1	120V 30Amp RV Receptacle	9	Fuel On/Off Knob	17	Recoil Handle
2	Ground Connection	10	Circuit Breaker	18	Oil Access Cover
3	120V NEMA-5 Receptacle	11	Parallel Connection	19	Fuel Tank Cap
4	5V DC USB 2.1A Outlet	12	Battery On/Off Switch	20	Engine Service Panel
5	DC Circuit Breaker	13	Economy Switch	21	Never-Flat Wheels
6	12V CLA Power Port	14	One-Push Start	22	Telescoping Handle
7	Charging Port - Internal Battery	15	Generator Status Light		
8	Start Indicator	16	Carry Handles		

## Introduction

Thank you for purchasing this 4500 watt portable inverter generator from JEGS. This generator is designed to give you years of reliable service when operated and maintained as instructed in this manual.

### Product Specifications:

This generator is an engine-driven, revolving field, alternating current (AC) portable generator. It is designed to supply electrical power to operate tools, appliances, camping equipment, lighting, or serve as a backup power source during power outages.

Source	Model	555-86012
AC Output	Rated AC Voltage	120V
	Rated Frequency	60Hz
	AC Current	20A & 30A RV
	Rated Output	3700W
	Maximum Output	4500W
DC Output	USB Outlet	5V DC 2.1A
	Cigarette Outlet	12V DC 8A
Engine	Displacement	224cc
	Engine Type	Single Cylinder, 4-Stroke, OHV Air Cooled
	Engine Oil Type	SAE 10w30
	Engine Oil Capacity	20.2 oz / 600ml
	Fuel Tank Type	3.17 gal / 12L

The emissions control system for this generator is compliant with all standards set by the US EPA.

### How to Contact Customer Service:

If you have questions regarding your purchase please contact customer service at: 1.800.345.4545.

Save your original sales receipt and record the following information below for service or warranty assistance.

Date of Purchase:	
Model Number:	
Serial Number:	

## Safety Symbols



Indicates a hazardous situation which could result in serious injury or death if not avoided.

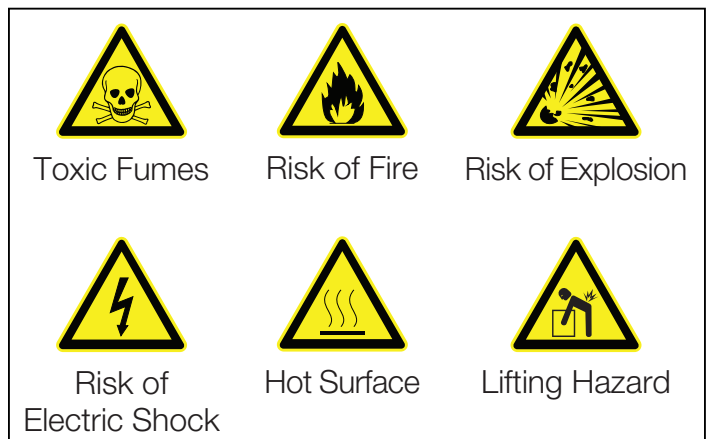

## Safety Rules

The manufacturer cannot anticipate every possible circumstance that the user may encounter hazards. Therefore, the warnings in this manual, on tags, and on affixed decals are not all-inclusive. To avoid accidents, the user must understand and follow all manual instructions and use good common sense.

 **WARNING!** Read and understand this manual in its entirety before operating this generator. Improper use of this generator could result in serious injury or death.

 **Do not operate indoors or in a confined space that prevents dangerous carbon monoxide gas from dissipating.**

- Using a generator indoors **CAN KILL YOU IN MINUTES!**
- Carbon monoxide gas is a poisonous, odorless gas that can cause headache, confusion, fatigue, nausea, fainting, sickness, seizures, or death. If you start to experience any of these symptoms, **IMMEDIATELY** get fresh air and seek medical attention.
- Never use indoors, in a covered area, or in a confined space, even if the doors and windows are open.
- Install a battery-operated carbon monoxide alarm near bedrooms.
- Keep exhaust this unit produces from entering a confined area through windows, doors, vents, or other openings.
- When working in areas where vapors could be inhaled, use a respirator rated for carbon monoxide protection.



**The engine exhaust contains chemicals that can cause cancer and birth defects.**

- Always wash hands after handling generator.



**To reduce the risk of serious injury, use caution when lifting the generator.**



**Never exceed the generator's wattage/ amperage capacity. This may damage the generator and/or connected devices.**

- Check operating voltage and frequency of all electrical devices prior to plugging into generator.



**Never start or stop the engine with electrical devices plugged into the receptacles. Failure to do so could damage the generator and/or connected devices.**

- Always start the engine and let it stabilize before connecting any electrical devices.
- Disconnect all electrical devices before stopping the engine.



**Starter recoil and other moving parts can catch on clothing, jewelry, and hair.**

- Do not wear loose clothing or loose gloves.
- Remove jewelry or anything else that could be caught in moving parts.
- Tie back hair, or wear protective head covering to contain long hair.



**The generator must be properly grounded to prevent electrocution.**

- Only operate the generator on a level surface.
- If connected to a structure, connect the ground terminal to an appropriate ground.

## Safety Rules Cont.



### Keep away from flammable objects and other hazardous materials.

- The fuel and its vapors used to power this unit are highly flammable and could explode resulting in serious injury or death.
- Never fill or drain fuel tank indoors.
- Never overfill fuel tank. If fuel spills, move the unit at least 30 feet away from the spill and wipe up any remaining fuel on the unit before starting the engine.
- Never smoke while operating or fueling this unit.
- Never operate or store this unit near an open flame, heat, or any other ignition source.
- Generator should be far away from buildings or other equipment during operation.
- Keep engine free of grass, leaves, grease, and other flammable debris.
- When adding or draining fuel, unit should be turned off for at least 2 minutes to cool before removing fuel cap. If unit has been running, the fuel cap may be under pressure, remove slowly.
- To keep fuel from spilling, secure unit so it cannot tip while operating or transporting.
- When transporting unit, disconnect the spark plug wire and make sure the fuel tank is empty with the fuel shutoff valve turned to the off position.



### Never modify this unit in any way or modify governed engine speed.

- Increasing the governed engine speed is dangerous and can result in personal injury and/or damaged equipment.
- Decreasing the governed engine speed adds an excessive load and can damage the equipment.
- This generator will supply the correct rated frequency and voltage only when operating at the preset governed speed.



### Avoid touching hot areas of this unit.

- Only operate the generator on a level surface.
- If connected to a structure, connect the ground terminal to an appropriate ground.



### This generator produces high voltage which may result in burns/electrocution causing serious injury or death.

- Never handle the generator, electrical devices, or any cord while standing in water, while barefoot, or when hands or feet are wet.
- Always keep the generator dry. Never operate generator in rain or under wet conditions.
- Use a ground fault circuit interrupter (GFCI) in a damp or highly conductive area, such as metal decking or steel work.
- Never plug electrical devices into generator having frayed, worn, or bare wires. Never touch bare wires or contact receptacles.
- Never permit a child or unqualified person to operate generator. Always keep children a minimum of 10 feet away from the generator.
- If using the generator for backup power, notify the utility company.
- If connecting generator to a building's electrical system for standby power, you must use a qualified electrician to install a transfer switch. Failure to isolate the generator from the power utility could result in serious injury or death to electric utility workers.



### Pull cord recoils rapidly and can pull arm towards engine faster than you can let go which could result in injury.

- To avoid recoil, pull starter cord slowly until resistance is felt, then pull rapidly.

## ***Safety Rules Cont.***



**Only use as intended. Used incorrectly serious injury or death could result.**

- Do not bypass any safety device. Moving parts are covered with guards. Make sure all protective covers are in place.
- Never transport or make adjustments to this unit while it is running.
- Never insert objects into cooling slots.



**Never operate this unit if there are any broken or missing parts.**

- Improper treatment of this generator can shorten it's life.
- Always repair this unit as specified in this manual.
- Shut generator off if electrical output is missing, unit vibrates excessively or begins to smoke, spark, or emit flames.

# Control Panel Functions

## Fuel Valve Knob

When the knob is in the “OFF” position, the fuel valve is closed and the engine will not run.

When the knob is in the “ON” position, fuel valve is opened and the engine can run.

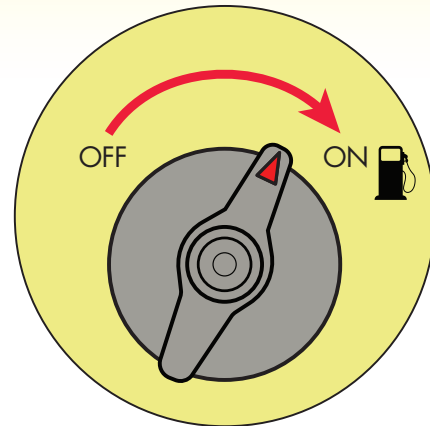

## USB Power Outlet

The Generator offers convenient (5V DC 2.1A) USB outlet to allow charging of USB devices like Tablets, MP3 players, GPS, Digital Cameras and other USB chargeable devices.

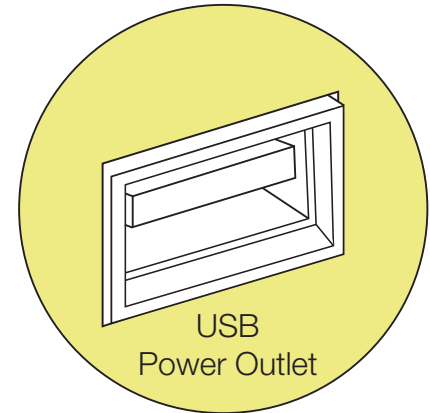

## Oil Warning Indicator Light

When the oil falls below the minimum level, the oil warning indicator light comes on and the engine stops automatically. The engine will not start until the proper amount of oil is in the crank case.

## Engine Overload Indicator Light

If the engine overload indicator light comes on, the generator’s wattage / amperage capacity has been exceeded by connected electrical devices or by a power surge. When this occurs, the green AC Pilot Indicator Light will go off. The engine will continue to run, (but the red Engine Overload Indicator Light will stay on and power will no longer be supplied to connected electronic devices.)

**Note:** The engine overload indicator light may turn on for a few seconds when attaching a load due to a power surge. This is normal.

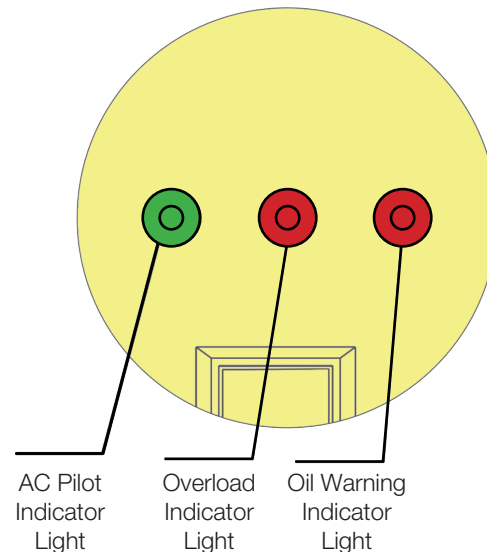



## Control Panel Functions Cont.

### How to Correct

- Disconnect any attached electrical devices and then stop the engine.
- Reduce the total wattage of the connected electrical devices until it is within the generator's rated output.
- Inspect the Air Inlet and Control Panel for any blockage. Remove blockage if found.
- Restart Engine.

### AC Pilot Indicator Light

The green AC Pilot Indicator Light comes on when the engine starts and generates power.

### DC Circuit Breaker

When the DC Circuit Breaker is in the "I" position, the generator is able to supply power to connected electronic devices. When the DC Circuit Breaker is in the "O" position, the generator will no longer supply power. The DC Circuit Breaker automatically shifts to the "O" position when connecting electronic devices to the generator that exceed the generator's rated output. If the DC Circuit Breaker shifts to the "O" position, reduce the load of connected electronic devices until the load is within the specified rated output. To re-establish power, return the DC Circuit Breaker back to the "I" position.

### Engine Economy Control

- When the Engine Economy switch is turned to the "ON" position, the economy control unit automatically determines the generator's proper

engine speed based on the connected electronic load. This results in superior fuel economy and reduces noise.

- When the Economy switch is turned to the "OFF" position, the engine runs at the rated speed of 4,100 rpm.

**Note:** The Economy switch must be in the "OFF" position when using electronic devices that require a large starting current, such as a compressor.



**If the DC circuit breaker turns off again, stop using the generator immediately and consult a qualified electrician or small engine repair shop.**

### Parallel Connections

Located just above the Ground Terminal, the generator's Parallel Connections enable the user to run two 86012 generators simultaneously. This feature requires special cables and a parallel kit. When operating generators in parallel, the rated output is 7.4kVA and the rated output is 61.6A/120VAC.



**Never connect two generators that are different models.**

- Only connect to another 86012 Generator.
- Only use a parallel operation cable kit designed to work with this generator.

## Control Panel Functions Cont.

### Fuel Cap

Turn cap counterclockwise to remove.

### Fuel Cap Air Vent

The fuel cap is equipped with an air vent to stop fuel from flowing to the carburetor. The Air Vent must be in the "ON" position to allow fuel to flow so that the engine can run. Turn the Air Vent to the "OFF" position to stop fuel flow.

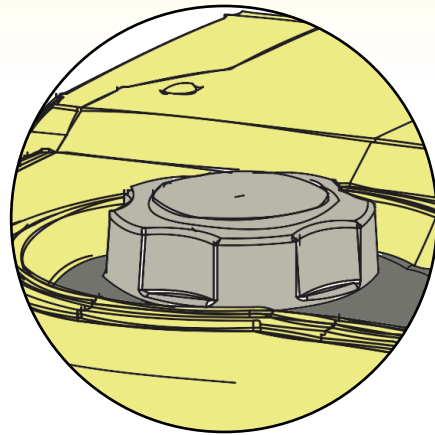

### Grounding the Generator

This portable 4500 Watt inverter generator is equipped with a terminal for the connection of a ground electrode conductor where a grounding electrode system is required by NEC Article 250.34(A). The equipment grounding conductors of the generator receptacles are bonded to the generator's frame. Where the generator supplies power to cord and plug connected equipment, like power tools, the frame of the generator is not required by the NEC to be connected to an earthen ground electrode. The generator neutral conductor is bonded to the generator's frame in accordance with NEC Article 250.34(C).

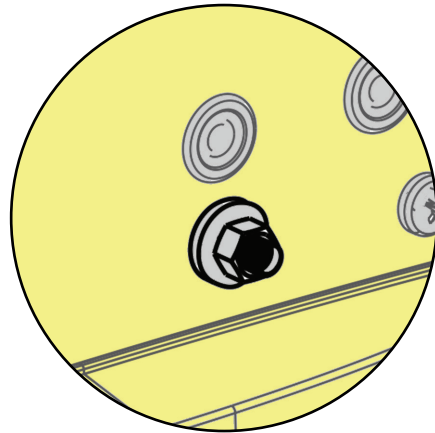

**Generator must be properly grounded to prevent electrocution.**

- Only operate generator on a level surface.
- Always connect the nut and ground terminal on the frame to an appropriate ground source.

## Assembly

### Connecting the Generator to an Electrical System

If you are connecting the generator to a building's electrical system for standby power, you must use a qualified electrician to install a transfer switch. The power from the generator must be isolated from the circuit breaker or alternative power source. The connection must comply with all electrical codes and applicable laws.

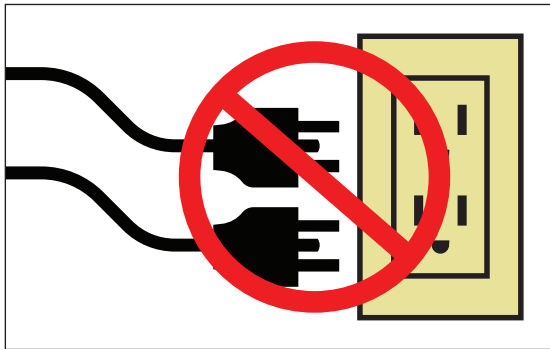

Never directly connect the generator to a household power source.

### Adding Fuel

- Set generator outdoors in a well-ventilated area, away from structures and people.
- Slowly remove fuel cap.
- Insert a funnel into the fuel tank and carefully pour gasoline into the tank until fuel level reaches 1 ½ inches below the top of the neck. Be careful not to overfill the tank, to allow space for fuel expansion.

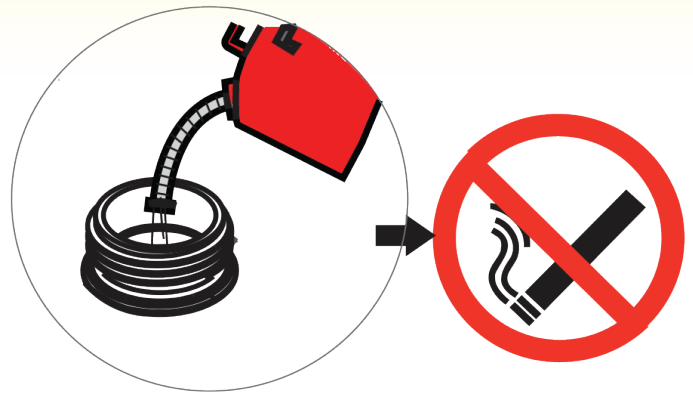

Do not smoke when adding fuel.

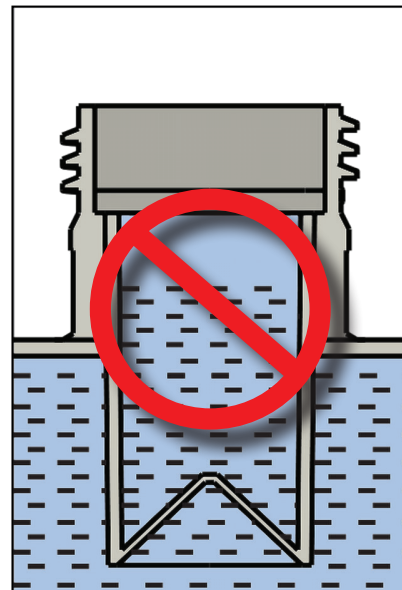

Do not overfill the fuel tank. Provide space for fuel expansion

## Assembly Cont.

### Battery Installation

1. Loosen four Phillips screws, but do not remove them from the side panel.
2. Carefully lift all four edges of the side panel, releasing the clip; then lift it away.
3. Insert battery into the holder until it clicks firmly in place.
4. Carefully line up the side panel and press the edges until the side panel is completely flush and evenly installed.
5. Tighten all four Phillips screws.

**Note:** This generator is equipped with a battery charging feature. When the engine is running, a small charge is supplied to the battery.

### Adding and Checking Engine Oil

- Place generator on a firm level surface.
- Unclip and remove the oil service panel to access the oil fill/dipstick.
- Unscrew and remove the crankcase dipstick.
- Insert a funnel into the crankcase dipstick hole and carefully add the engine oil (SAE 10W-30) to the reservoir until oil reaches the outer edge of the oil fill hole (crankcase dipstick hole).
- Be sure to replace dipstick and tighten securely before attempting to start the engine.
- To check oil, with the ENGINE OFF and COOL, set generator on a firm level surface, unscrew and remove dipstick, wipe dipstick clean, then reinsert dipstick without re-threading.

### Specifications

- **Recommended Oil:** SAE 10W-30
- **Oil Capacity:** 20.2 oz. (0.6 L)

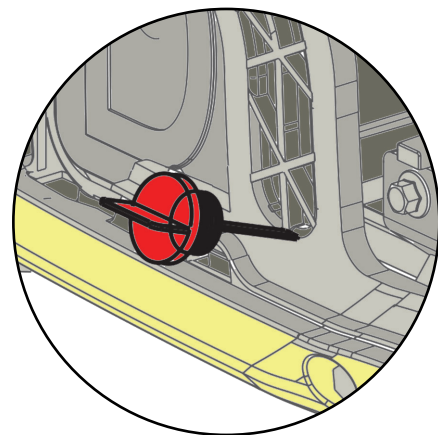
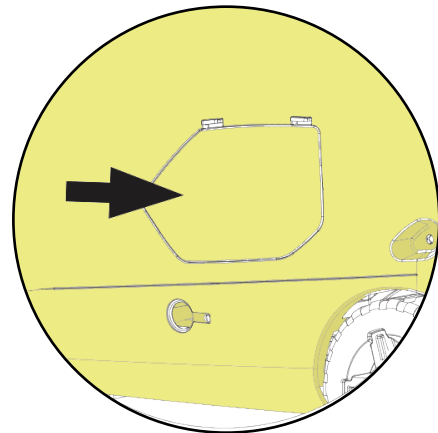
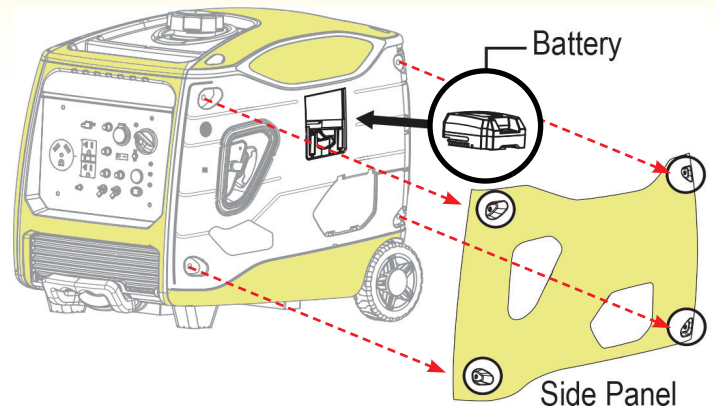

**⚠ This generator has been shipped without engine oil. You must add oil before operating this unit. Always check the oil level before each use.**

# Operation

## Standard Atmospheric Conditions

- **Ambient Temperature:** 77° F (25° C)
- **Barometric Pressure:** 100 kPa
- **Relative Humidity:** 30%

The generator output will vary due to changes in temperature, altitude, and humidity. If the humidity, temperature, or altitude are higher than standard atmospheric conditions, the generator's output will be reduced. The load attached to the generator must therefore be reduced.

## How to Start the Engine

- Place generator on a level surface. All electrical loads MUST be disconnected from generator.
- Battery ON/OFF Switch to "ON" position
- Turn the FUEL VALVE Knob to "ON"
- Pull the recoil starter grip slowly until resistance is felt; retract, then pull rapidly.

## Push Button & Remote Fob Starting

- Place generator on a level surface. All electrical loads MUST be disconnected from generator!
- Battery ON/OFF Switched to "ON" position. Turn the FUEL VALVE Knob to "ON"
- **Push Button Start:** Push and hold down the Start Button for no more than 1 second and then release. This will tell the generator to automatically set the

choke and begin the starting sequence. If it fails to start successfully, repeat this step. If it fails to start after 5 attempts, refer to the "TROUBLESHOOTING" section on page 24 of the operator's manual

- **Remote Start:** Push and hold start button for no more than 1 second and release
  - Make sure generator battery is connected.

**Note:** Shipping restrictions for Lithium-Ion batteries require that they be shipped in a low state of charge. It may be necessary to charge the starting battery before normal operation. Therefore, it is recommended to use the manual recoil starter, when starting the generator for the first time and allow the starting battery time to recharge.

### Push-Button & Remote Start

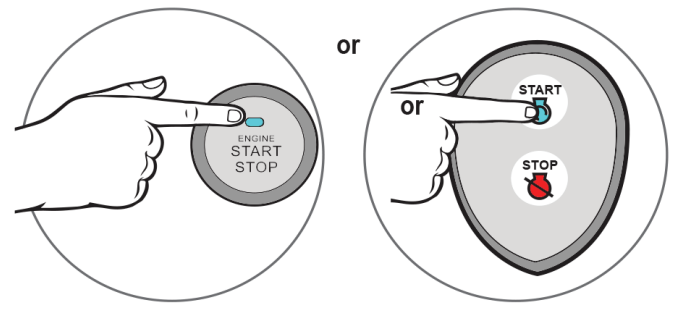

### Manual Start

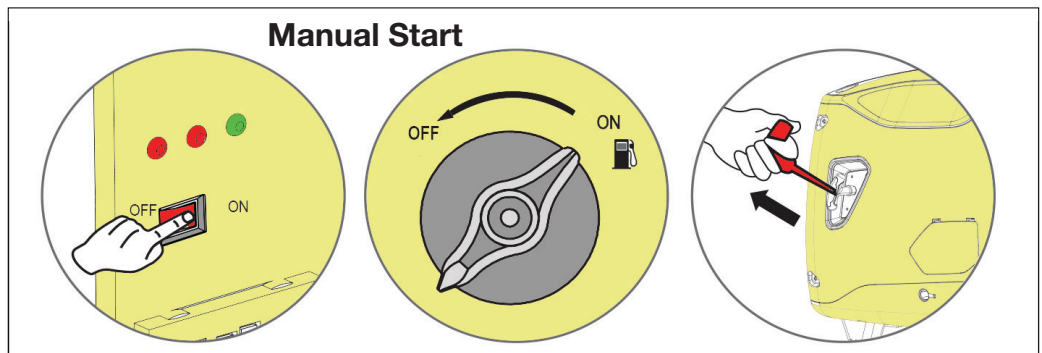

## Operation Cont.

### Pull cord recoils quickly and could result in injury

- To avoid recoil, pull the starter cord slowly until resistance is felt, then pull rapidly.

**Note:** Steps to start the generator with the Economy switch in the “ON” position

- Disconnect all electrical loads from generator.
- If ambient temperature is below 32°F (0°C) allow about 3 minutes for the engine to warm up.
- The Economy is in “ON” position, the unit returns to normal operation after the above warm up time.
- Economy switch must be turned to the “OFF” position when using electronic devices that require a large starting current.

### How to Pair the Remote Fob

- Push and hold the One Push Start Button for about 10 seconds.
- Wait for the start light on the control panel to flash green.
- Within 3 seconds, press any button on the remote FOB for about 1 second and release.
- Make sure the green light has stopped flashing, to indicate successful pairing.

### How to Stop the Engine

- Turn the FUEL VALVE Knob to the “OFF” position.
- Disconnect any electrical devices. All loads MUST be disconnected from the generator. Never start or stop the engine with electrical devices plugged in to the receptacles.
- Push the One Push Start Button.
- Or for Remote Stop push the Stop button.
- Or turn Battery ON/OFF Switch to “OFF”.

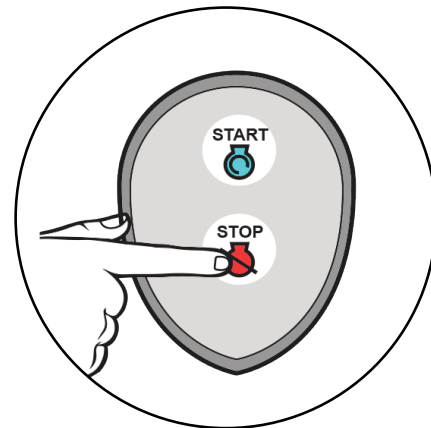
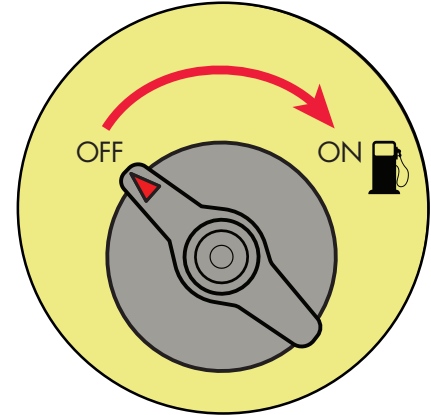
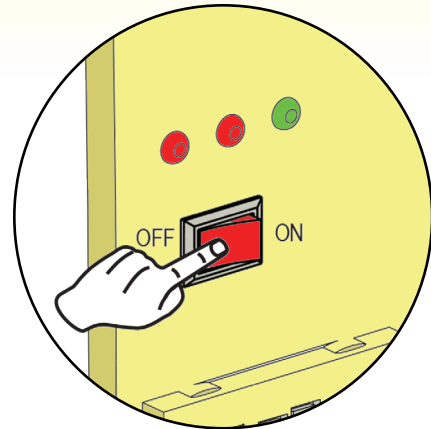

## Operation Cont.



**Never start or stop engine with electrical devices plugged in to the receptacles. Failure to do so could damage the generator and / or connected electrical devices.**

- Always start the engine and let it stabilize before connecting any electronic devices.
- Disconnect all electronic devices before stopping the engine.

### How to Attach Electronic Devices

1. Before Starting generator
  - Make sure the generator is grounded (see page 9 for instructions).
  - Make sure the attached load is within the generator rated output and the receptacle's rated current.
  - Make sure all electrical cords and receptacles are in good condition.
  - Make sure all of your electronic devices are turned "OFF" before plugging them into the generator.
2. Start the engine.
3. If the attached load is small, turn the Economy switch to the "ON" position. For a larger load, or if attaching multiple electronic devices turn the Economy switch to the "OFF" position.
4. Make sure the green AC pilot indicator light is on.
5. When the engine has stabilized, plug in and turn on first load. It is strongly recommended to plug in devices with the largest output first and the smallest output last to help prevent overloading the generator.
6. Allow generator output to stabilize (engine and attached devices run evenly) before plugging in the next load.

### Charging a 12 Volt Battery

This generator can be used to charge 12 volt automotive or storage batteries by taking the following steps.

1. Inspect fluid level of the battery cells. Add ONLY distilled water to any cell where fluid level is low. Never add tap water.
2. Clean battery terminals with a brush if corroded.
3. Securely connect the red cable clamp to the positive (+) battery terminal.
4. Securely connect the black cable clamp to the negative (-) battery terminal.
5. Turn the Economy switch to the "OFF" position to start battery charging.
6. Battery is considered fully charged when the voltage is at or above 12.7vdc, when measured by a volt meter.

**Note:** It is strongly recommended to check battery voltage level at least once per hour with a volt meter to prevent overcharging and to test the battery's condition.

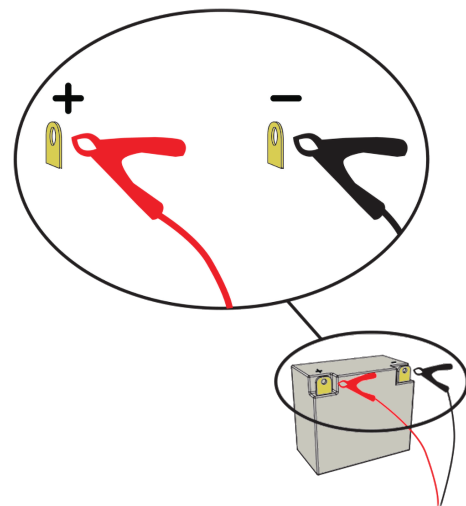

## Operation Cont.



### **Battery electrolyte is poisonous and dangerous**

- Do not disconnect the battery clamps while charging. Batteries produce explosive gases. Disconnecting the battery clamps while charging could cause a spark and ignite.
- Do not charge a battery in an enclosed area.
- Never smoke while charging the battery, or operating, or fueling this generator.
- Battery electrolyte contains sulfuric acid. Avoid contact with skin, eyes, and clothing. Always wear eye protection when charging battery.
- If battery acid contacts skin, flush with water immediately. If it contacts eye, flush with water for 15 minutes and get immediate medical attention. For internal ingestion, drink large quantities of milk or water, followed by milk of magnesia, beaten egg, or vegetable oil. Contact a medical physician immediately.

### **AC Parallel Operation**

It is possible to connect two 86012 generators to each other, using a parallel cable kit, to increase available power output.

- You may connect PARALLEL OPERATION CABLES to two 86012 generators according to the instructions provided with parallel cable kit.
- Make sure the Economy switch is in the same position on both generators.
- All electrical devices should be turned "OFF" and disconnected from generators prior to starting generator engines.
- Start generator engines. Make sure the green AC Pilot indicator light comes on for each generator.
- When engines have stabilized, plug in electrical devices to AC receptacle and turn on first load.

- Allow generator output to stabilize (after the first electrical device is added to an AC receptacle on the parallel cable kit) before plugging in the next electrical load.

Limit start-up time to 3 seconds for load requiring maximum output. For continuous operation, do not exceed the rated output.

**Note:** It is strongly recommended to plug in devices with the largest electrical demand output first and the smallest electrical demand last to help prevent overloading the generator.

**Note:** Most electrical devices require power beyond its rated wattage to start. This additional power is referred to as surge watts and motor-based start-up loads usually last between 2-3 seconds. When an electrical device is started, the red overload indicator may come on. This is normal. If the light stays on disconnect all electrical devices and stop the engine.



**Only connect electronic devices to the generator that are in good working order and do not exceed the rated power supply of the parallel generators or the desired receptacle.**

- A faulty appliance or power cord can create an electric shock. Do not use electronic devices that have a damaged cord or plug.
- If an appliance begins to operate abnormally, becomes sluggish, or stalls, turn off and disconnect appliance immediately. The appliance may have a fault or its rated load capacity exceeds the power supply of the generator.
- To avoid damage to generator or electronic device, do not connect a load to the generator if its electrical rating exceeds that of the receptacle.



## Operation Cont.



**Never connect generators that are different models.**

- Only connect to another 86012 Generator.
- Only use a JEGS approved parallel operation cable kit to connect generators.
- Never exceed maximum power, this setup may be used for no more than 30 minutes.
- The parallel cable must be removed if operating only one generator.
- Never disconnect or remove the parallel operation cable while the generator is still running.

### Don't Overload the Generator

Make sure that your generator can supply enough rated watts and surge watts for all electrical loads connected to the generator. Surge watts refer to the power a generator must supply to start an electrical device. This power surge for starting a device usually lasts between 2-3 seconds but this additional output must be considered when selecting the electrical devices you plan to attach to the generator.

Operating voltage and frequency requirement of all electrical equipment should be verified prior to plugging them into this generator. Damage may result if the equipment is not designed to operate within a +/- 10% voltage variation, and +/- 3 Hz frequency deviation from the generator name plate ratings.



**Never exceed generator's wattage/ amperage capacity. This could damage the generator and connected electrical devices.**

- Verify the operating voltage and frequency requirements of all electrical devices prior to plugging in to the generator.

## Operation Cont.

### Wattage Reference Guide

(Wattages listed are approximate. Check electrical devices for actual wattage.)

Essentials	Rated Watts	Surge Watts
75 W Light Bulbs	75 ea.	75 ea.
18 Cu. Ft. Refrigerator	800	2200
Furnace Fan (1/2 hp)	800	2350
Sump Pump (1/2 hp)	1000	2000
Water Pump (1/2 hp)	1000	3000
Heating/Cooling		
Dehumidifier	650	800
Table Fan	200	300
Window AC (10k BTU)	1200	3600
Central Air (4 ton)	1500	6000
Electric Blanket	400	400
Space Heater	1800	1800
Kitchen		
Blender	300	900
Toaster (2 slices)	1000	1000
Coffee Maker	1500	1500
Electric Range (1 element)	1500	1500
Dishwasher	1500	2000
Electric Oven	3500	3500
Electric Water Heater	4000	4000
Laundry Room		
Iron	1200	1200
Washing Machine	1150	2400
Gas Clothes Dryer	700	1500
Electric Clothes Dryer	5400	6750
Bathroom		
Hair Dryer	1250	1250
Curling Iron	1000	1000

Family Room	Rated Watts	Surge Watts
X-Box or PlayStation	40	40
AM/FM Radio	10	10
DVD	100	100
TV or Monitor (40 in.)	200	200
Home Office		
Fax Machine	65	65
Computer	800	800
Printer	250	950
Copy Machine	700	800
Power Tools		
1000W Work Light	1000	1000
Airless Sprayer (1/3 hp)	600	800
Reciprocating Saw	750	950
Circular Saw (7 1/2 in.)	1400	2300
Miter Saw (10 in.)	800	1200
Table/Radial Arm Saw	1000	2000
Electric Drill (5.4 Amps)	600	900
Hammer Drill	700	1000
Air Compressor	1600	4500
Other		
Home Security	500	500
Garage Door Opener	750	750

 **Never exceed generator's wattage/ amperage capacity. This could damage the generator and connected electrical devices.**

# Maintenance

Regular maintenance will extend the life of this generator and improve its performance. The warranty does not cover items that result from operator abuse, misuse, or negligence. To receive full value from the warranty, operator must maintain the generator as instructed in this manual, including proper storage.



**Before inspecting or servicing this machine, make sure the engine is off and no parts are moving. Disconnect the spark plug wire and move it away from the spark plug.**

## Maintenance Schedule

### Pre-Operation Steps

Before starting the engine, perform the following pre-operation steps:

- Check the level of the engine oil and the fuel tank level. Check for any leakage.
- Make sure the air filter is clean.
- Remove any debris that has collected on the generator and around the muffler and controls. Use a vacuum cleaner to pick up loose debris. If dirt is caked on, use a soft bristle brush.
- Inspect work area for hazards.

### After Each Use

Perform the following procedure after each use:

- Turn the FUEL VALVE Knob to "OFF"
- Switch OFF the engine
- Switch Off the battery
- Wait for the generator to become cool to the touch
- Store unit in a clean and dry area.

<b>After first 5 Hours</b>	Change engine oil
<b>After 8 Hours or Daily</b>	Clean debris from generator and air filter area
	Check engine oil level
<b>Annually (25 hr. Usage)</b>	Check and clean air filter
	Change engine oil after the first 25 hours, again at 50 hours, and then every 100 hours after.
	Inspect condition of muffler and spark arrestor
<b>Annually (100 hr Usage)</b>	Service spark plug (Replace with NGK BP6ES, Champion N9YC, or equivalent)
	Inspect fuel valve and fuel lines for leaks or damage
	Inspect condition of muffler and spark arrestor
	Check and clean the air filter assembly. Replace air filter
	Clean cooling system cylinder head fins and flywheel fan

## Carburetor Adjustment

The carburetor is low emission and is equipped with a non-adjustable idle mixture valve.

## High Altitude Operation

It is important to note that when used at high altitudes, above 5,000 ft., the carburetor's air/fuel mixture will be too rich. Performance will decrease, and fuel consumption and emissions will increase.

## Maintenance Cont.

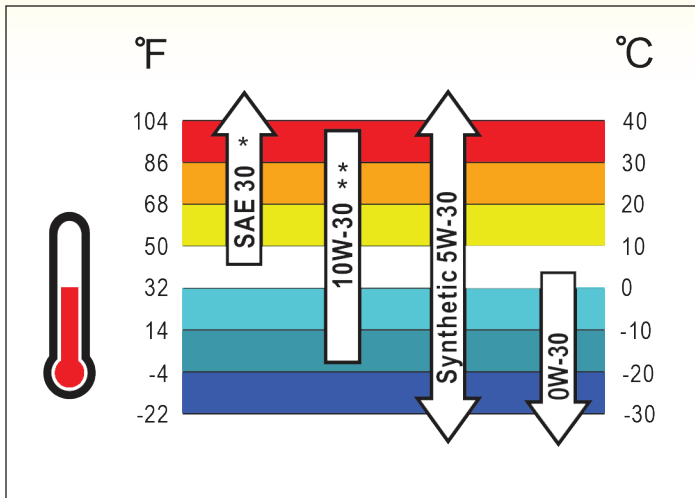

### Note:

- Below 40° F (4° C) the use of SAE 30 will result in hard starting.
- Above 80° F (27° C) the use of 10W-30 may cause increased oil consumption. Check oil level more frequently

### Checking the Spark Plug

- Remove the Engine Service Panel to gain access to the spark plug.
- Remove the plug wire from the spark plug.
- Before removing the spark plug, clean the area around its base to prevent debris from entering the engine.
- Insert a 19mm, 6-point, deep-well spark plug socket wrench through the opening on the outside of the cover. Turn the wrench counter-clockwise to loosen and remove spark plug.
- Check for discoloration and clean carbon deposits from the electrode with a wire brush.
- Check the electrode gap and slowly adjust to 0.024-0.028 in. (0.6 - 0.7mm) if necessary.
- Reinstall spark plug and tighten to 15 ft-lbs (20.0Nm) of torque.

- If spark plug is worn, replace only with an equivalent type. Spark plug should be replaced annually regardless of apparent condition.
- Reconnect spark plug wire, firmly, until it clicks into place.

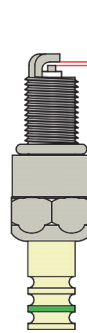

0.6-0.7mm **Standard Spark Plug**

- Torch F6TC/F6RTC

### Spark Plug Gap

- 0.024-0.028 in. (0.6-0.7 mm)

### Spark Plug Torque

- 15 ft-lbs (20.0 Nm)

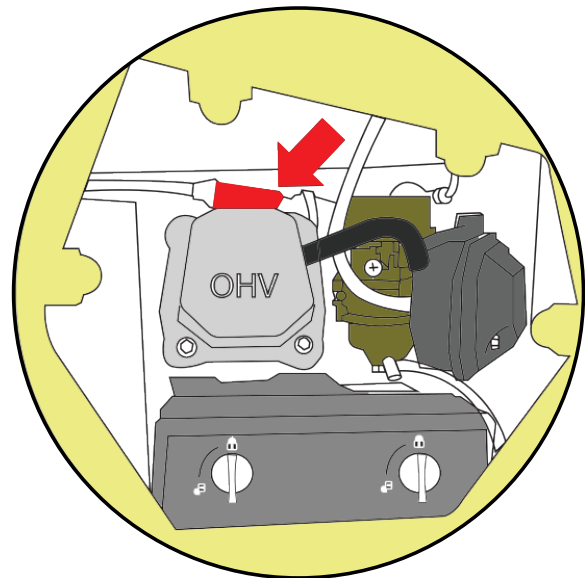

Pull off spark plug cover.

## Maintenance Cont.

### Changing Oil

- Run the generator until the engine is warm, then shut OFF.
- Place generator on a firm and level surface, raised on blocks for easier access.
- Remove the crankcase dipstick.
- Place an oil pan underneath the oil drain hole to collect used oil.
- Remove the oil drain plug and allow oil to drain completely.
- Reinstall oil drain plug, tighten securely.
- Carefully add SAE 30 or 10W-30 engine oil to empty reservoir until the oil reaches the threads of the oil fill hole (Crankcase Dipstick hole).
- Replace crankcase dipstick.

### Oil Specifications

- **Recommended Engine Oil:** SAE 10W-30
- **Recommended Engine Oil Grade:** API Service Type SE or higher engine oil
- **Engine Oil Quantity:** 20.2 oz. (0.6 L)

### Oil Recommendations

- Do not use special additives.
- Outdoor temperatures determine the proper oil viscosity for the engine. Use the chart to select the best viscosity for the outdoor temperature range expected.

 **Do not tilt generator when adding oil. This could result in overfilling which could damage the engine. Make sure no foreign matter enters the crankcase.**

### Air Filter

A dirty air filter will reduce the lifespan of the engine, make it difficult to start and reduce performance. Replace with a new filter annually.

- To clean, remove the screws then remove left outer casing.
- Turn the spring latches to lift then open air filter cover.
- Remove the pleated paper filter
- Blow the dust away with a compressed air
- Reinsert the paper filter into the air filter case.

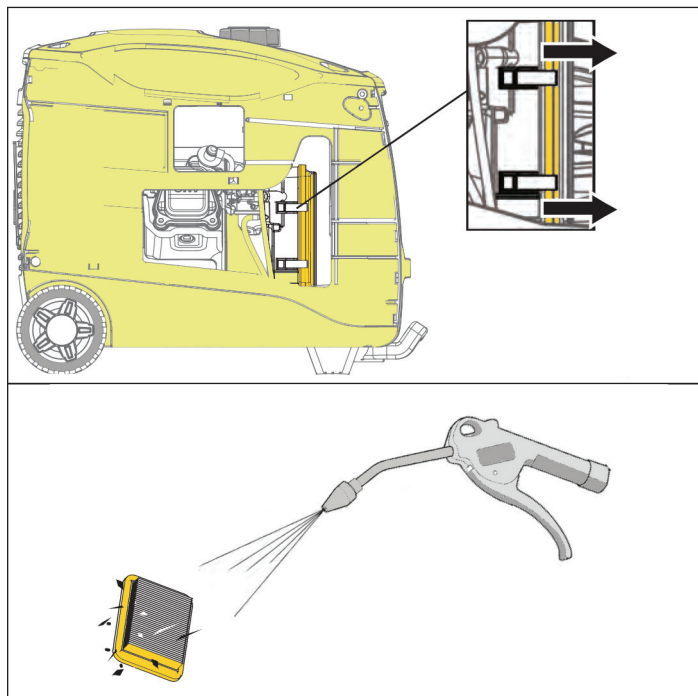

 **Do not run the generator without reinstalling the foam element or excessive piston and cylinder wear may result, or excessive engine wear may result.**

## Maintenance Cont.

### Checking Muffler and Spark Arrester

- Inspect the muffler for cracks, corrosion, or other damage.
- Remove screws, then remove the muffler cover as shown.
- Loosen bolt, then remove muffler cap, muffler screen, and spark arrester.
- Check the muffler screen and spark arrester for carbon deposits. Remove carbon deposits with a wire brush.
- Check the muffler screen and spark arrester for damage. If damaged replace with parts specifically designed for this unit.
- Install spark arrester.
- Align the spark arrester projection with hole in the muffler pipe.
- Install the muffler screen and muffler cap.
- Install the outer casing and tighten the screws.



**Avoid contacting hot areas with this unit.**

- Use caution around the muffler, cylinder, and other engine parts as they can be extremely hot.
- Allow hot components to cool before touching.

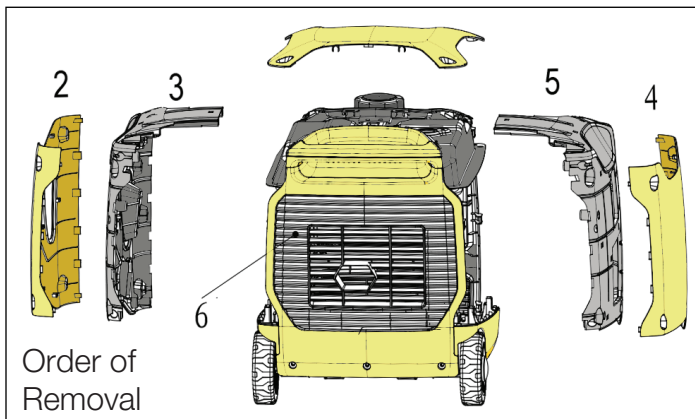

### Fuel Tank Filter

- To clean, remove fuel cap and filter.
- Clean filter with gasoline.
- Wipe the filter with a clean rag.
- Install filter.
- Install fuel cap

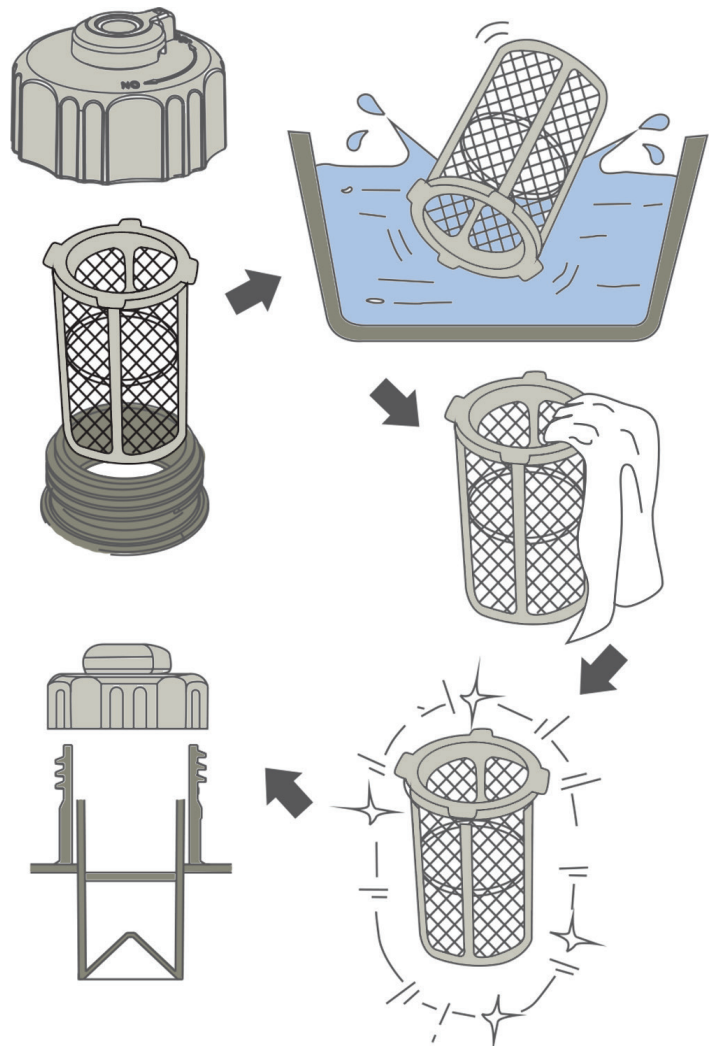

# Transport & Storage

## Storage and Transportation of the Generator

When transporting the generator, set the 3-in-1 start switch to Off. Keep the generator level to prevent fuel spillage.

- Remove any debris that has collected on the generator and around the muffler and control panel. Use a brush or vacuum to remove dirt.
- Inspect air cooling slots. Remove any debris.
- For short-term storage, start the generator once every 7 days.
- For semi-long term storage, add fuel stabilizer to prevent stale fuel from causing acid and gum deposits in the fuel system and carburetor.
- For long-term storage, drain the fuel.
- Store indoors to prevent freezing of unit and use a protective cover to protect from dust.
- The generator must be shipped, run, and stored in the upright position.

## Engine Long Term Storage

- Remove the spark plug and pour about 1 teaspoon of 10W30 engine oil into the spark plug hole. Reinstall the spark plug. Turn fuel valve knob to the OFF position pull the recoil starter cord several times to coat the cylinder walls with oil.
- Slowly pull the recoil starter cord until you feel the engine build compression (when you feel resistance). Leave the engine in this state as this will prevent corrosion on the cylinder walls when stored for a long period of time.



**The drain tube is just used for drain fuel.**

## How to Drain Fuel

- Turn OFF the engine, move the battery switch to OFF, turn the fuel valve to OPEN, remove the fuel cap and the debris screen underneath the fuel cap.
- Empty the fuel tank using a siphon and an approved gasoline container.
- Position a container under the carburetor drain tube. Loosen the drain valve screw.
- Allow fuel to completely drain and re-tighten the drain valve screw.
- Turn the fuel valve to CLOSED and replace the fuel cap.

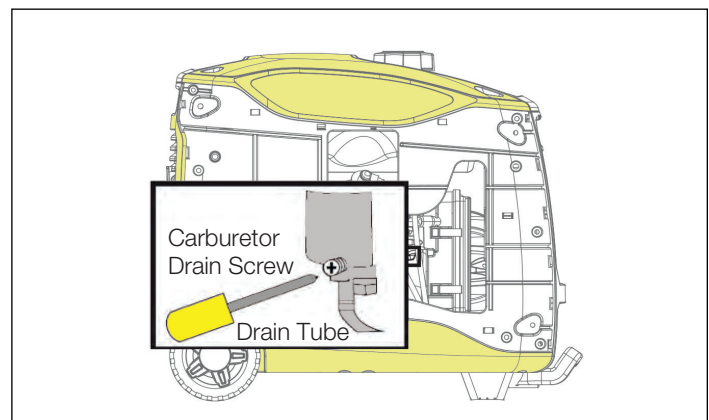
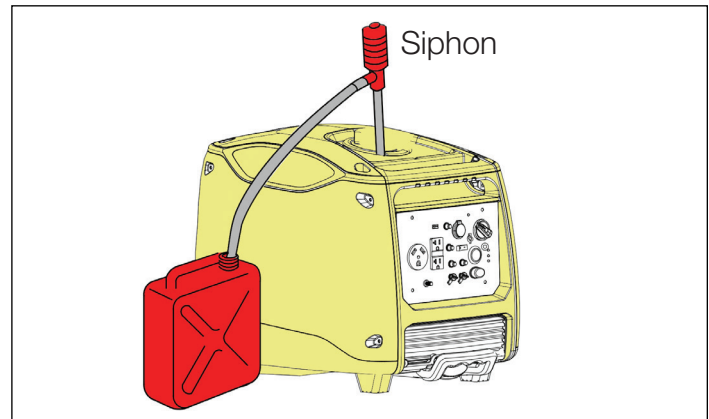

# Troubleshooting

Problem	Cause	Solution
Generator is running, but does not supply power.	<ol style="list-style-type: none"> <li>1. Open circuit breaker</li> <li>2. Poor connection</li> <li>3. Defective cord set</li> <li>4. Connected device is faulty</li> <li>5. Fault in generator</li> </ol>	<ol style="list-style-type: none"> <li>1. Reset circuit breaker</li> <li>2. Check and repair</li> <li>3. See above solution (#2)</li> <li>4. Connect a device that is working properly</li> <li>5. Contact tech sales</li> </ol>
Engine runs well without load, but bogs down when loads are connected	<ol style="list-style-type: none"> <li>1. Short circuit in connected device</li> <li>2. Generator is overloaded</li> <li>3. Clogged fuel filter</li> <li>4. Engine speed is too slow</li> <li>5. Short circuit in generator</li> </ol>	<ol style="list-style-type: none"> <li>1. Disconnect device</li> <li>2. See "Don't overload generator" on pg. 16</li> <li>3. Clean or replace fuel filter</li> <li>4. Contact tech sales</li> <li>5. See above solution (#4)</li> </ol>
Engine will not start, shuts down during operation, or starts and runs rough.	<ol style="list-style-type: none"> <li>1. On/Off switch set to "Off"</li> <li>2. Dirty air filter</li> <li>3. Clogged fuel filter</li> <li>4. Out of fuel or stale fuel</li> <li>5. Spark plug wire disconnected from spark plug</li> <li>6. Bad spark plug</li> <li>7. Water in fuel</li> <li>8. Fuel knob on "Off" position</li> <li>9. Low oil level</li> <li>10. Engine has flooded</li> </ol>	<ol style="list-style-type: none"> <li>1. Turn switch to "On"</li> <li>2. Clean or replace air filter</li> <li>3. Clean or replace fuel filter</li> <li>4. Replace fuel</li> <li>5. Reconnect spark plug wire</li> <li>6. Clean or replace spark plug</li> <li>7. Drain fuel tank and replace fuel</li> <li>8. Turn fuel knob to "ON" position</li> <li>9. Check oil level</li> <li>10. Wait 5 minutes and re-start</li> </ol>
Engine lacks power	<ol style="list-style-type: none"> <li>1. Generator is overloaded</li> <li>2. Clogged in-line fuel filter</li> <li>3. Dirty air filter</li> <li>4. Engine needs servicing</li> </ol>	<ol style="list-style-type: none"> <li>1. See "Don't overload generator" on pg. 16</li> <li>2. Replace in-line fuel filter</li> <li>3. Replace air filter</li> <li>4. Contact tech sales</li> </ol>
Engine "hunts" or falters	<ol style="list-style-type: none"> <li>1. Clogged fuel filter</li> <li>2. Carburetor is running too rich or too lean</li> </ol>	<ol style="list-style-type: none"> <li>1. Replace-inline fuel filter</li> <li>2. Contact tech sales</li> </ol>



# Wiring Diagram

