



COLD AIR SYSTEM

Installation Instructions for:
Part Number 21-406
1997 - 2001 Honda Prelude

ADVANCED ENGINE MANAGEMENT INC.
2205 126TH Street, Unit A Hawthorne, CA. 90250
Phone: (310) 484-2322 Fax: (310) 484-0152
www.aempower.com
Instruction Part Number: 10-203
1997-1998 Honda Prelude H22A4 C.A.R.B. E.O. #D-392-5
1999-2001 Honda Prelude H22A4 C.A.R.B. E.O. #D-392-11
© 1998 Advanced Engine Management, Inc.

Congratulations! You have just purchased the finest Air Induction & Filtration system for your car at any price!

The **AEM** Cold Air System is the result of extensive development on a wide variety of cars. Each system is engineered for the particular application. The **AEM** Cold Air System differs from all others in several ways. We take the inlet air from outside of the engine compartment where the inlet air is considerably cooler than the hot underhood air. The cooler inlet air temperature translates to more power during the combustion process because cool air is denser than warm air. **AEM** has conducted extensive inlet air temperature studies and we have seen temperature reductions of up to 50 degrees by pulling air from outside of the engine compartment. The air mass flow to the engine is increased because of the increased airflow *and* reduced inlet temperature, which translates to more power. The **AEM** Cold Air Systems are **50 states Street Legal** (some models and years still pending) and come with complete instructions for ease of installation.

Our system is constructed of lightweight aluminum and then painted with a zirconia based powder coat for superior heat insulating characteristics. The aluminum will not crack in extended use like plastic and it is actually lighter than plastic. The tube diameter and length are matched for each engine to give power over a broad rpm range. Unlike the plastic systems that use a continually diverging cross section, we take advantage of the acoustical energy in the duct to promote cylinder filling during the intake valve-opening event.

Our Dyno testing as well as **independent dyno tests** (see 7/97 Sport Compact Car Magazine) prove that the **AEM** Cold Air System produces as much as twice the power gain than any other system on the market.

Bill of Materials for:

Part Number 21-406 1997 - 2001 Honda Prelude

<u>QTY</u>	<u>PART #</u>	<u>DESCRIPTION</u>
1	21-203	3" AEM Air Filter & Hose Clamp
1	2-421	Inlet Pipe
1	8-105	1/8" Vacuum Cap
1	444.460.04	6mm Nut
1	559999	6mm X 25mm X 1mm Washer
1	1228599	Rubber Mount
1	5-273	2.75/300 " Hose Adapter
1	103-BLO-4420	2.75" Hose Clamp
1	103-BLO-4820	3.00" Hose Clamp
12"	65128	3/8" Breather Hose
16"	516-006	5/16" Water Hose
4	4093-5	3/4" Hose Clamp
1	10-203	Instructions
1	10-922S	Regular AEM Decal
1	10-400W	White License Plate Frame
1	10-905	Warning Decal
1	11-406	E.O. Decal

Read and understand these instructions BEFORE attempting to install this product.

1. Make sure vehicle is parked on a level surface.
2. Set parking brake.
3. Disconnect negative battery terminal.
4. If engine has run within the past two hours let it cool down.
5. The following items will be removed from the vehicle.
 - (a) The OE inlet tube.
 - (b) The air filter case.
 - (c) Intake air noise resonators underneath the air filter case (inside fender well).
6. Raise the front of the vehicle and support it using jack stands. **Make sure that the jack stands are rated for the vehicle's weight.**
7. **Removal of intake air tube.**
 - (a) Disconnect the breather tube assembly.
 - i) Disconnect the water bypass hose from throttle body or the fast idle thermo valve, where equipped, located at the lower portion of the throttle body. Disconnect the opposite side of the water bypass hose, which runs to either the intake manifold or the water outlet neck. Remove the entire water bypass hose and breather hose assembly from the vehicle.
 - ii) Disconnect the metal breather tube from both the cam cover and the stock air inlet tube.
 - (b) Loosen the hose clamp holding the air tube to the throttle body.
 - i) Remove the inlet hose from the throttle body and carefully lift it up.
 - ii) Separate the inlet tube from the air filter case and lift the inlet tube out and away from the area of work.
 - (c) Disconnect the vacuum hoses and electrical connections that run to the Intake Air Control (IAC) solenoid valve. This valve controls the Intake Control Diaphragm (ICD). These components reduce the amount of intake noise generated in the stock system. AEM's Cold Air System eliminates these components.
 - i) Remove the IAC solenoid valve from the vehicle. For reference, the IAC solenoid valve is a little black box located behind the battery and underneath the stock inlet tube.
 - ii) Remove the aluminum bracket that mounts the IAC solenoid valve.
8. **Removal of air filter case**
 - (a) Undo the two bolts holding the air filter case and lift it away from the vehicle. It may be easier to separate the top half from the bottom half and then remove the bottom half from the vehicle. You can then assemble the air filter case and set it aside for storage.
9. **Removal of the lower resonator**
 - (a) Remove the stone shield underneath the front of the vehicle.
 - (b) Remove the front right inner fender well cover from underneath.
 - (c) Remove the bolts holding the lower resonator from the vehicle and lower the resonator away from the vehicle.
10. **Preparation for installation of the inlet pipe.**
 - (a) Looking at the area once occupied by the air filter case you will observe a hole utilized by the filter case. This hole must be enlarged to accept the new air inlet pipe. The hole shown in the photograph shows one example of how large it can be to accommodate the pipe. **The main requirement is that the pipe clears all adjacent bodywork when it is installed.**
11. **Installation of inlet pipe**
 - (a) Install one black connector hose on the throttle body end of the pipe. The throttle body end has the nipple next to it. Install a hose clamp on the connector hose and snug it down.
 - (b) Install the pipe onto the vehicle. You may have to maneuver the pipe to achieve proper placement.

- i) The support tab on the inlet pipe will line up with one of the threaded holes that was used to mount the IAC solenoid valve mounting bracket. Install the rubber mount into the rearmost hole that was left exposed by the removal of the IAC solenoid valve bracket, and attach the air inlet tube onto the rubber mount. Install the large fender washer and the lock nut onto the rubber mount stud and snug it down. **Failure to install the rubber mount will void the warranty of the Cold Air System.** Below is a diagram of how the rubber mount is installed.

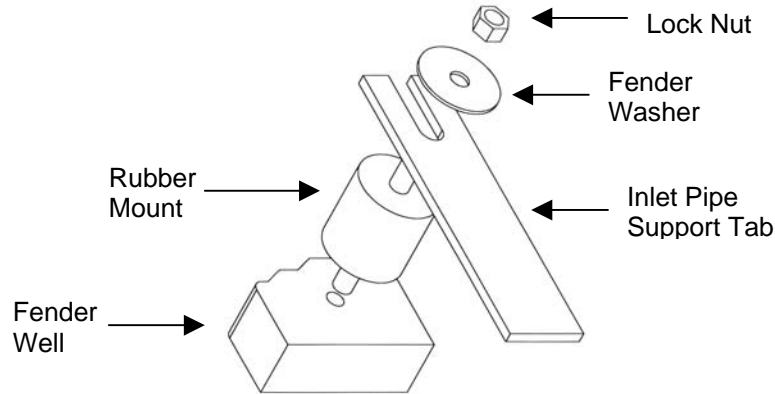

- (c) Connect the new supplied water bypass hose and clamps to the throttle body or the fast idle thermo valve, where equipped, and either the intake manifold or the water outlet neck disconnected earlier.
- (d) Install the breather hose in place of the tube that was removed in step 7(b). The metal tube assembly will not be used.
12. Install the **AEM** filter on to the end of the inlet tube. Push the filter on around 2 inches over the inlet pipe and install one hose clamp to secure the filter on to the inlet pipe. Once fitment is checked, you can either push the filter on to the inlet pipe more or less depending on clearances. Tighten the hose clamp after this is done.
13. **Re-assembly of stone shield**
- (a) ***Failure to install inner fender well (splashguard) will result in diminished performance and increase potential for engine damage by the ingestion of water during wet weather conditions.***
- i) Assemble the inner fender well cover that was removed to gain access to the resonator.
- ii) Assemble the front stone shield.
14. **Prepare to start**
- (a) Replace the coolant lost from Step 7a.
- (b) Check for any loose tools, lines, leaks.

**For Technical Inquiries
Please E-Mail Us At
tech@aempower.com**

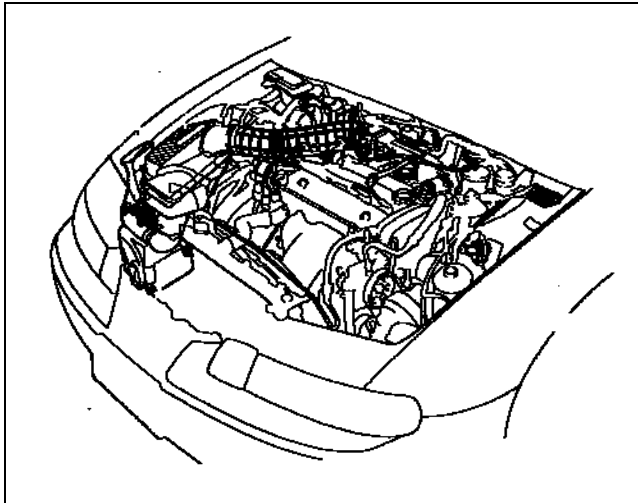

Fig 1: Layout of the intake system

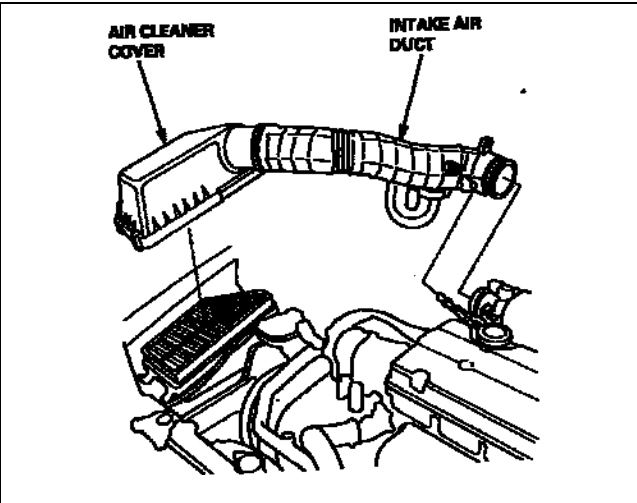

Fig 2: Removing stock air duct

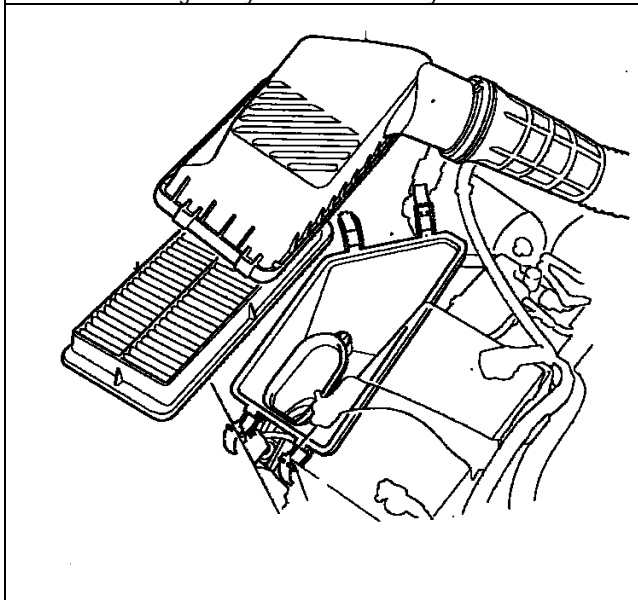

Fig 3: Air filter case

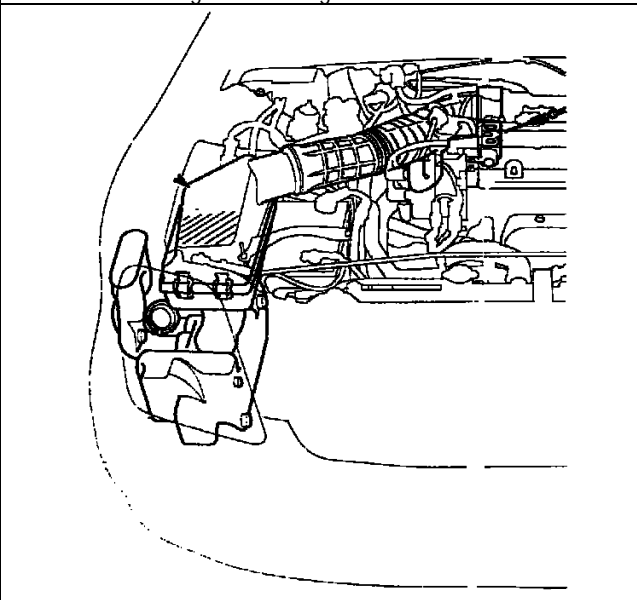

Fig 4: Air filter system layout (front)

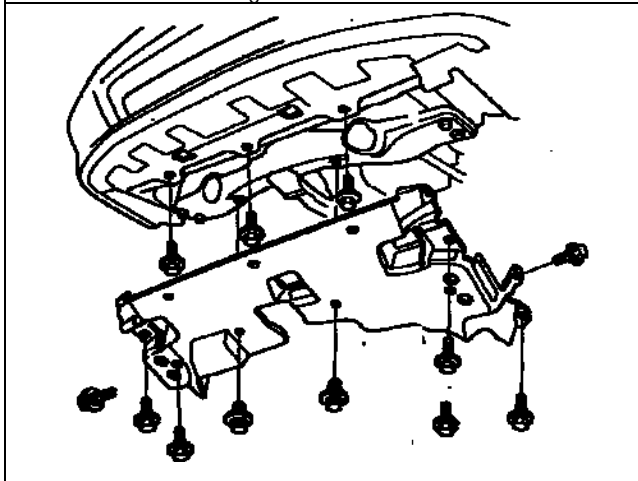

Fig 5: Lower splash shield

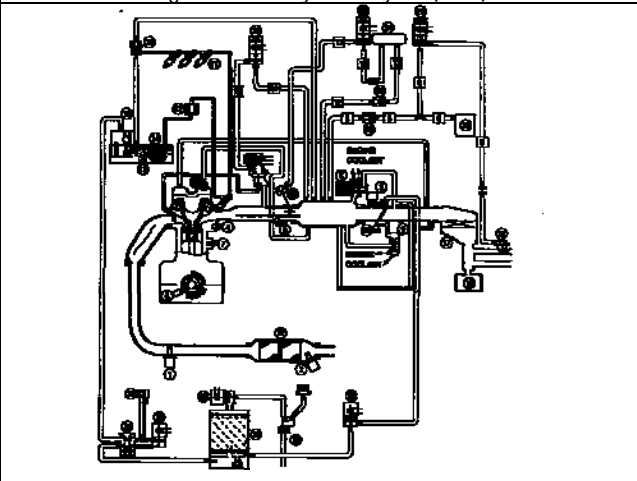

Fig 6: Vacuum hose routing

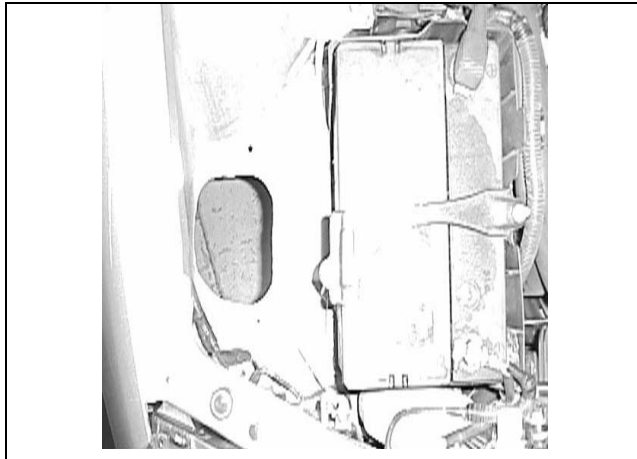

Fig 7: Hole cut into fender well (battery on right)



Fig 8: Air pipe installed

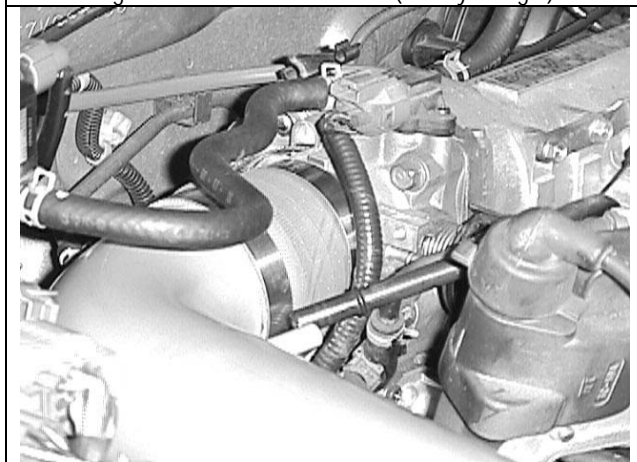

Fig 9: Connecting to throttle body. Note breather tube.

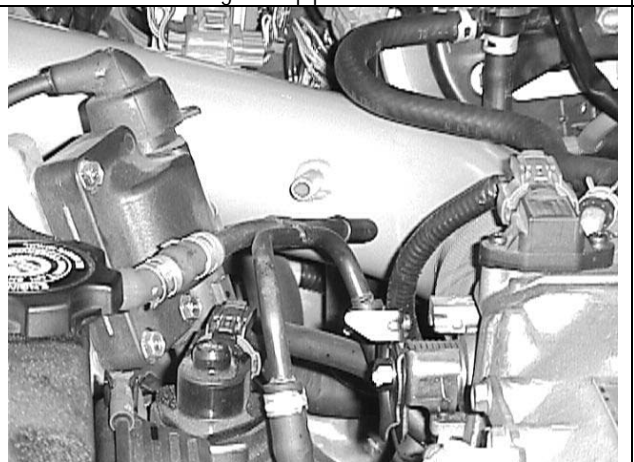

Fig 10: Breather tube and port



Fig 11: Air pipe installed. Note mounting bolt.

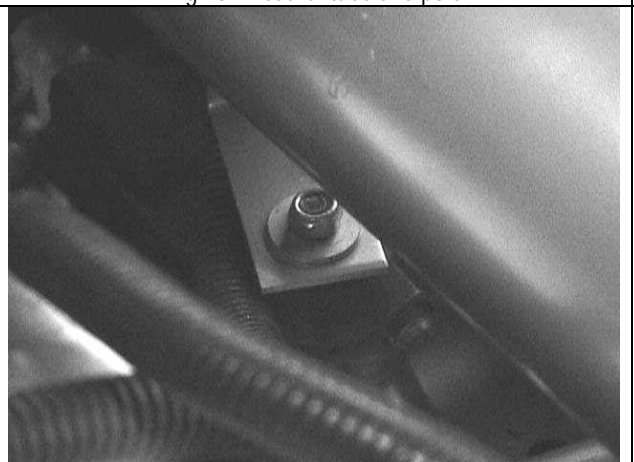

Fig 12: Mounting bolt