

# INSTALLATION INSTRUCTIONS

## 57-1525

Dodge

1994-02 Ram

L6-5.9L Turbo Diesel

NOTE: This kit was not designed to fit vehicles with a body lift.

### TOOLS NEEDED:

Flat blade screwdriver  
4mm Allen wrench  
7/16" Wrench  
10mm Wrench

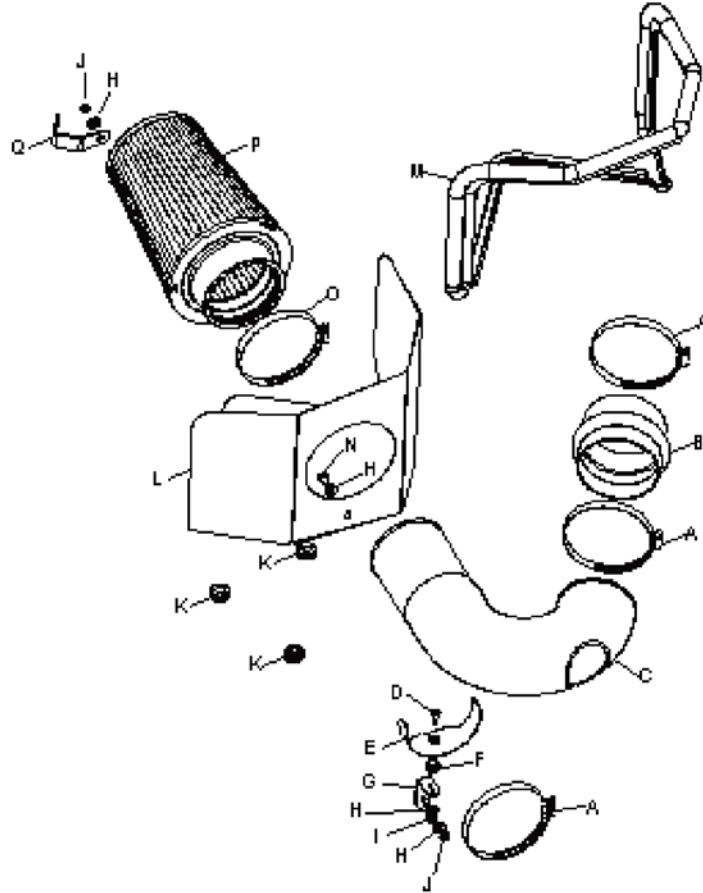

### PARTS LIST:

A	Hose clamp #64	3	08648
B	Hump hose	1	087040
C	Intake tube	1	087025
D	Bolt, 6mm, F/H/A	1	08376
E	Saddle bracket	1	078855
F	Washer, cup	1	08180
G	Bracket	1	070015
H	Washer, 1/4"ID x 5/8"OD SAE	4	08275
I	Nut, 6mm nylock	1	07553
J	Nut, 1/4-20 nylock zinc	2	07517
K	Grommet	3	08092
L	Heat shield	1	07453
M	Edge trim, 56"L	1	102490
N	Bolt, 1/4-20 hexhead	1	08315
O	Hose clamp #72	1	08671
P	Air filter	1	RC-4780
Q	Filter bracket	1	070021

**NOTE: FAILURE TO FOLLOW INSTALLATION INSTRUCTIONS AND NOT USING THE PROVIDED HARDWARE MAY DAMAGE THE INTAKE TUBE, THROTTLE BODY, AND ENGINE.**

### TO START:

1. Turn the ignition OFF and disconnect the vehicle's negative battery cable.



2. Loosen the hose clamp on the stock intake tube at the turbo.



3. Release the 4 clips that retain the airbox top to the airbox base. Detach the intake tube from the flange on the turbo and remove the upper air intake assembly.



4. Pull upward firmly on the airbox base to release it from its mounting studs and remove.

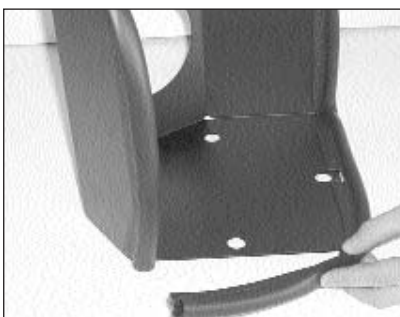

5. Install the edge trim on heat shield as shown.  
**NOTE: Trim as needed.**

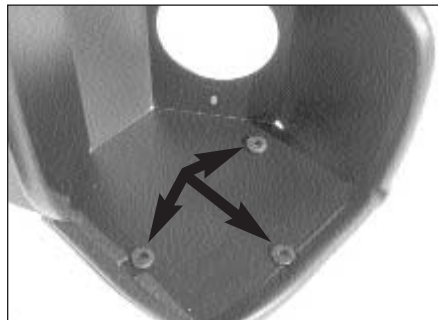

6. Install the three grommets provided onto the heat shield as shown.

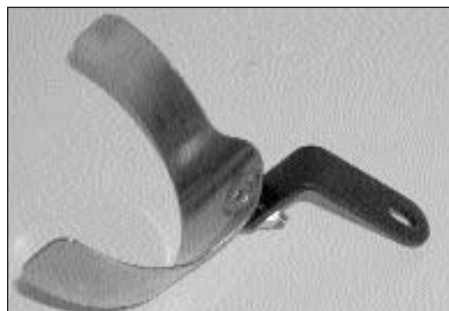

7. Assemble the "L" bracket and saddle bracket using the hardware provided.



8. Attach the saddle bracket to heat shield using the hardware provided.  
**NOTE: Do not tighten completely.**



9. Attach the hump hose onto the K&N intake tube as shown.

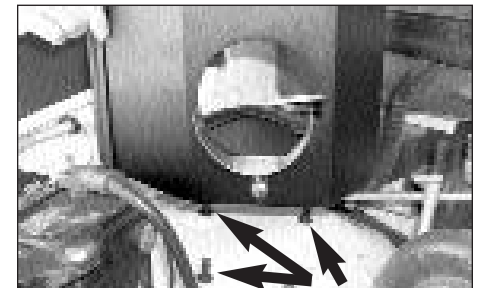

10. Install heat shield onto the locating studs as shown above.

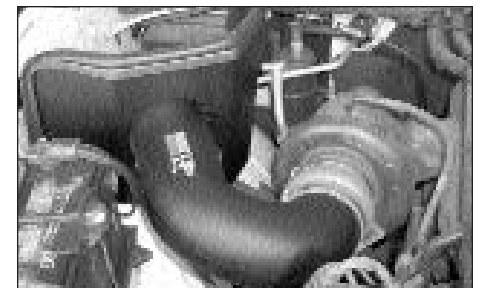

11. Slide the K&N intake tube through the heat shield and attach the hump hose to the flange on the turbo.



12. Install filter bracket provided onto the stud on the top plate of the air filter as shown.  
**NOTE: Do not tighten completely.**



13. Remove the filter restriction gauge and grommet from the stock airbox as shown.  
**NOTE: Use caution when removing gauge.**



14. Install the grommet and restriction gauge into the hole in the top plate of the air filter.



15. Loosen and remove the bolt that retains the hood hinge to the inner fender and remove hood hinge bolt from vehicle.

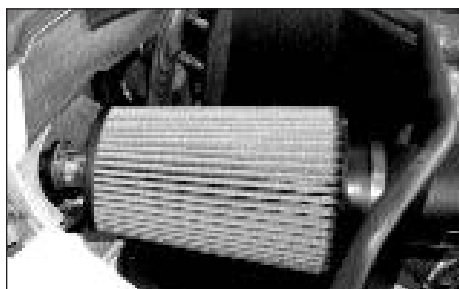

16. Install the air filter onto the intake tube.  
**NOTE: Do not tighten completely.**



17. Attach the filter bracket to inner fender using the bolt removed in step 15.  
**NOTE: Do not tighten completely.**

18. Adjust the air filter element and bracket for appropriate alignment and clearance, then tighten hardware.

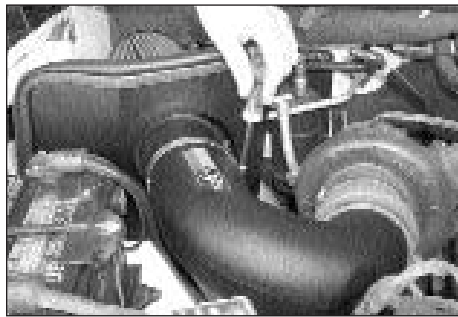

19. Attach saddle bracket to the intake tube with hose clamp provided. Adjust the bracket to achieve appropriate clearance for intake tube and tighten hardware.



20. Reconnect the vehicle's negative battery cable. Double check to make sure everything is tight and properly positioned before starting vehicle.

21. The C.A.R.B. exemption sticker, (attached), must be visible under the hood, so that an emissions inspector can see it when the vehicle is required to be tested for emissions. California requires testing every two years, other states may vary.

22. It will be necessary for all FIPK's to be checked periodically for realignment, clearance and tightening of all connections. Failure to follow the above instructions or proper maintenance may void warranty.

#### ROAD TESTING:

1. Start the engine with the transmission in neutral or park, and the parking brake engaged. Listen for air leaks or odd noises. For air leaks secure hoses and connections. For odd noises, find cause and repair before proceeding. This kit will function identically to the factory system except for being louder and much more responsive.

2. Test drive the vehicle. Listen for odd noises or rattles and fix as necessary.

3. If road test is fine, you can now enjoy the added power and performance from your kit.

#### IMPORTANT:

**Service air filter according to the K&N cleaning instructions (99-5050) when the indicator on the restriction gauge is in the 35 to 65% range. On vehicles that come with a numbered restrictor gauge, service the air filter when the indicator on the restriction gauge is in the 15 to 20" range. Do not run the vehicle with the indicator above the 65% or 20" range, as damage to the air filter and or the engine could result.**