

INSTALLATION INSTRUCTIONS

57-1527-1

Dodge
 1994-2001 Ram
 V6-3.9L

NOTE: This kit was not designed to fit vehicles with a body lift

TOOLS NEEDED:

- 10mm wrench
- 10mm socket
- Flat blade screwdriver
- Ratchet
- Phillips screwdriver
- 6" extension
- 5/8" wrench
- 4mm allen wrench
- 13mm wrench
- diagonal cutters

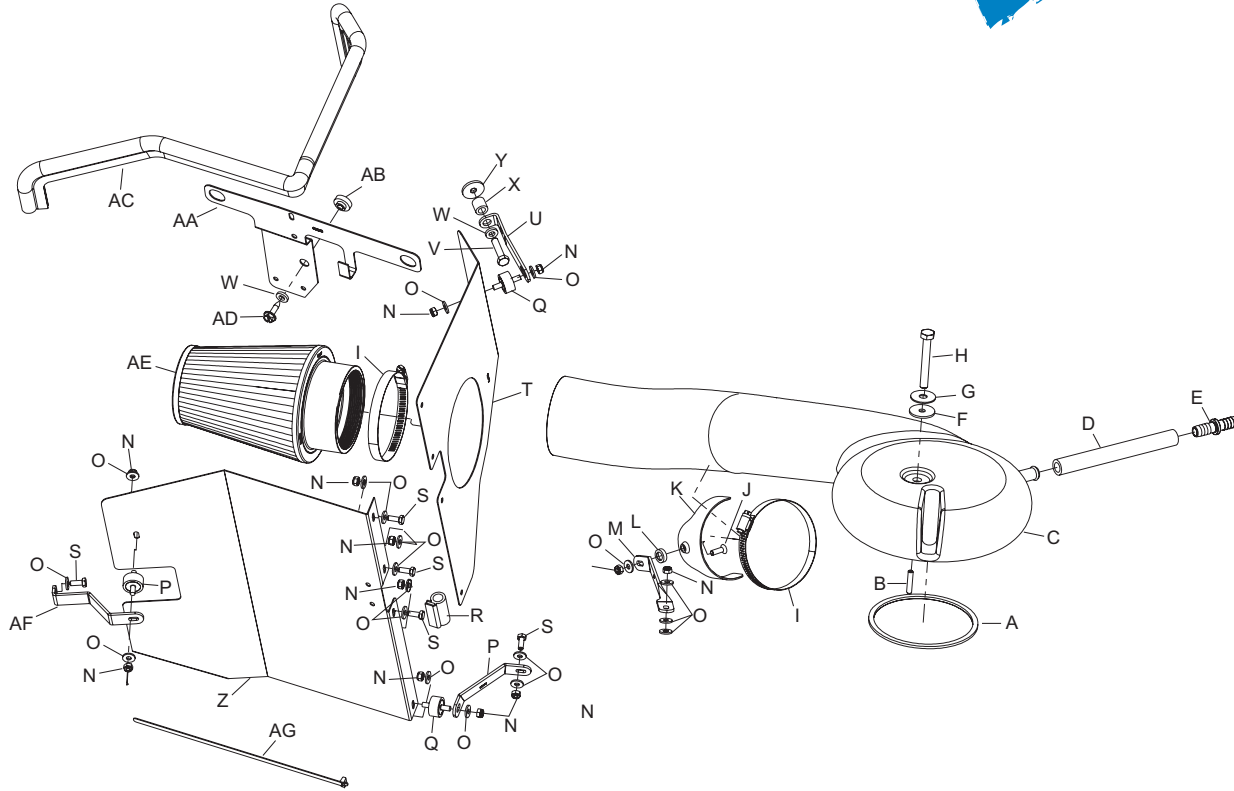

NOTE: FAILURE TO FOLLOW INSTALLATION INSTRUCTIONS AND NOT USING THE PROVIDED HARDWARE MAY DAMAGE THE INTAKE TUBE, THROTTLE BODY AND ENGINE.

TO START:

1. Turn the ignition OFF and disconnect the vehicle's negative battery cable.



2. Remove the air inlet duct as shown.



3. Disconnect the crank case vent hose as shown.



4. Loosen the hose clamp at the throttle body, then, remove the air cleaner assembly by pulling firmly upwards as shown.



5. Remove the stock grommet and the stock plastic locating pin as shown.



6. Remove the EVAP canister purge solenoid from the EVAP assembly bracket located on the inner fender as shown.

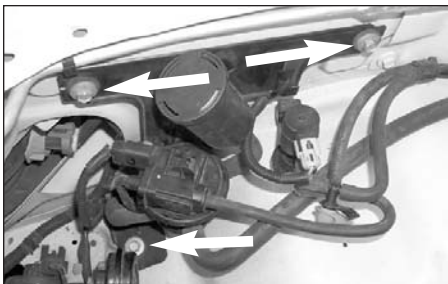

7. Loosen and remove the three bolts that secure the EVAP assembly bracket to the inner fender as shown.



8. Loosen and remove the EVAP canister vent from the EVAP assembly bracket as shown.

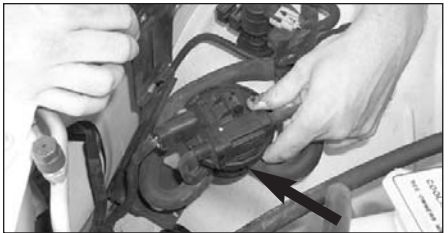

9. Loosen and remove the three screws that secure the EVAP canister to EVAP assembly bracket as shown.



10. Remove the EVAP assembly bracket from the vehicle as shown.

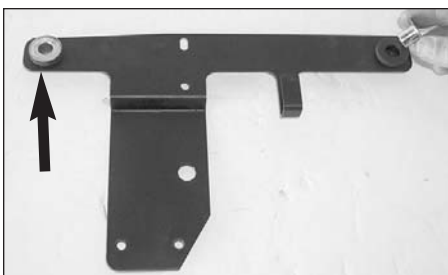

11. Remove the two upper stock metal stand-offs and the stock grommets from the stock EVAP assembly bracket and install them into the new K&N EVAP assembly bracket as shown.

PARTS LIST:

Description	Qty.	P/N
A Gasket	1	09989
B Screw; 1/4-20 x 1-1/4"L, set	1	07800
C Intake tube	1	087152
D Silicone hose	1	08159
E Hose mender, 1/2" barbed	1	08686
F Washer, 1.25 x .30 x .10 rubber	1	21708
G Washer, 1.25 x .40 x .62 ZN	1	08126
H Nut ext; 1/4-20 x 2.843L ZN	1	08241
I Hose clamp #64	2	08648
J Bolt; M6-1.00 x 20mm F/H/A ss	1	08376
K Saddle bracket	1	078855
L Washer; conical; nylon; black	1	08180
M Bracket	1	26619
N Nut 6mm nylock hexhead	12	07553
O Washer, 1/4" id x 5/8" od - sae	19	08275
P Bracket, Small "C"	1	26620
Q Stud, M6-1.00M/M; rubber mntd	3	07027
R Edge trim, 2"L	1	102497
S Bolt, M6-1.00x16mm hexhd tap	5	07703
T Heat shield A	1	07472
U Bracket, Small "L"	1	26618
V 8mm hex bolt	1	07784
W 5/16" flat washer	2	08276
X Spacer	1	07849
Y 5/16" fender washer	1	08130
Z Heat shield B	1	07473
AA Evap bracket	1	08028
AB Step bushing, rubber	1	21694
AC Edge trim, 37"L	1	102471
AD 5/16-18 x 1" sheet metal screw	1	07742
AE Filtercharger	1	RC-4680
AF Bracket "Z", 57-1511 Fin.	1	070652
AG Cable ties, 6" white	2	21591



12. Install the provided step bushing into the hole on the backside of the K&N EVAP assembly bracket as shown.



13. Install the EVAP canister onto the K&N EVAP assembly bracket using the original screws removed in step 9.



14. Install the EVAP canister vent onto the EVAP assembly bracket using the hardware provided as shown.



15. Remove the rubber mounted locating bracket from the purge control solenoid as shown.



16. Install the purge control solenoid onto the K&N EVAP assembly bracket as shown.

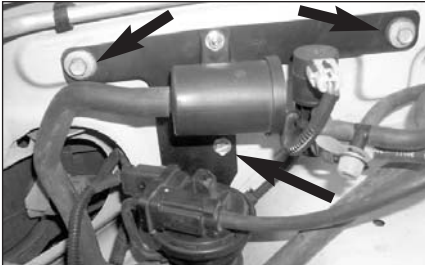

17. Using the two stock bolts and the provided sheet metal screw, secure the EVAP assembly bracket to the inner fender as shown.



18. Replace the stock throttle body gasket with the provided K&N gasket as shown.



19. Install the rubber mounted stud onto the K&N "Z" bracket using the provided hardware as shown.



20. Install the rubber mounted stud onto the K&N "L" bracket using the provided hardware as shown.



21. Secure the "Z" bracket to the radiator core support using the provided hardware as shown.



22. Secure the "L" bracket to the EVAP assembly bracket using the existing bolt as shown.



23. Install the provided edge trim onto the cut-out on the heat shield as shown.

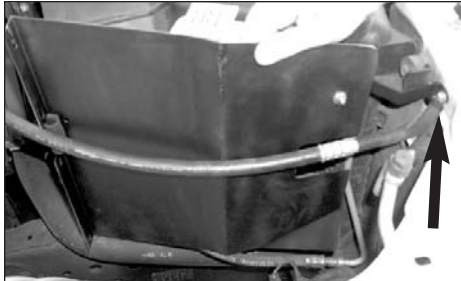

24. Install the first half of the heat shield into the vehicle and secure it to the "Z" bracket using the provided hardware as shown.

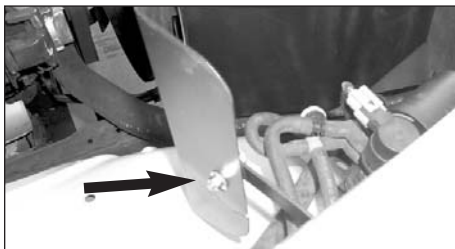

25. Install the second half of the heat shield into the vehicle and secure it to the "L" bracket using the provided hardware as shown.



26. Secure the rubber mounted stud onto the "C" bracket using the provided hardware as shown.

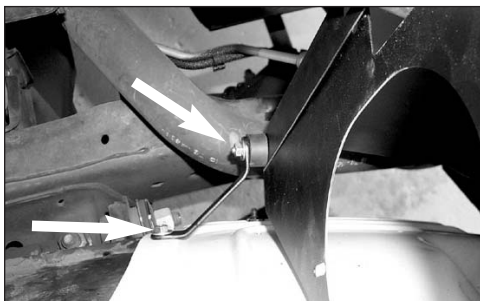

27. Install the bracket onto the inner fender using the provided hardware as shown, then, secure the rubber mounted stud to the bottom of the heat shield halves and secure with the provided hardware as shown.



28. Secure the two heat shield pieces using the provided hardware as shown, then, secure the A/C hard line to the heat shield using the provided zip tie as shown.

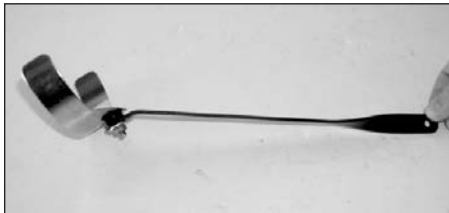

29. Assemble the saddle bracket assembly using the provided hardware as shown.



30. Install two washers onto the stock air cleaner mounting stud, then, install the saddle bracket assembly onto the stud and secure with the provided hardware as shown.



31. Install the provided set screw into the nut extension as shown with a minimum of about five threads engagement.

NOTE: Apply two drops of loc-tite to the throttle body stud. Failure to follow the above instructions may damage the throttle body



32. Install the K&N intake tube into the hole on the K&N heat shield, then, line up the other end with the throttle body as shown.

NOTE: Do not install onto the throttle body at this time.



33. Assemble the provided hose mender and the provided silicone hose as shown, then connect it to the stock crank case vent hose as shown.



34. Connect the silicone hose to the crank case vent on the K&N intake tube as shown.



35. Install the nut extension and the provided washers into the hole on the K&N intake tube as shown.



36. Position the K&N intake tube onto the throttle body, then, secure the K&N intake tube to the throttle body with the nut extension as shown.



37. Secure the K&N intake tube to the saddle bracket using the provided hose clamp as shown.



38. Install the provided edge trim onto the K&N heat shield as shown.



39. Install the K&N Filtercharger onto the K&N intake tube and secure it with the provided hose clamp as shown.



40. Using the provided zip tie, bundle up the EVAP assembly vent hoses as shown.

41. Reconnect the vehicle's negative battery cable. Double check to make sure everything is tight and properly positioned before starting the vehicle.

42. The C.A.R.B. exemption sticker, (attached), must be visible under the hood, so that an emissions inspector can see it when the vehicle is required to be tested for emissions. California requires testing every two years, other states may vary.

43. It will be necessary for all FIPK's to be checked periodically for realignment, clearance and tightening of all connections. Failure to follow the above instructions or proper maintenance may void warranty.

ROAD TESTING:

1. Start the engine with the transmission in neutral or park, and the parking brake engaged. Listen for air leaks or odd noises. For air leaks secure hoses and connections. For odd noises, find cause and repair before proceeding. This kit will function identically to the factory system except for being louder and much more responsive.

2. Test drive the vehicle. Listen for odd noises or rattles and fix as necessary.

3. If road test is fine, you can now enjoy the added power and performance from your kit.

4. K&N suggests checking the Filtercharger element periodically for excessive dirt build-up. When the element becomes covered in dirt (or once a year), service it according to the instructions on the Recharger service kit, part number 99-5050 or 99-5000.

***FREE K&N DECAL To register your warranty, please see us online at knfilter.com/register. FREE K&N DECAL ***