



AIRCHARGER®

INSTALLATION INSTRUCTIONS

57-2502

Ford
1989-93 Mustang
V8-5.0L

This kit fits vehicles with
mass-air sensors only
(will not fit 1988 non-california models)

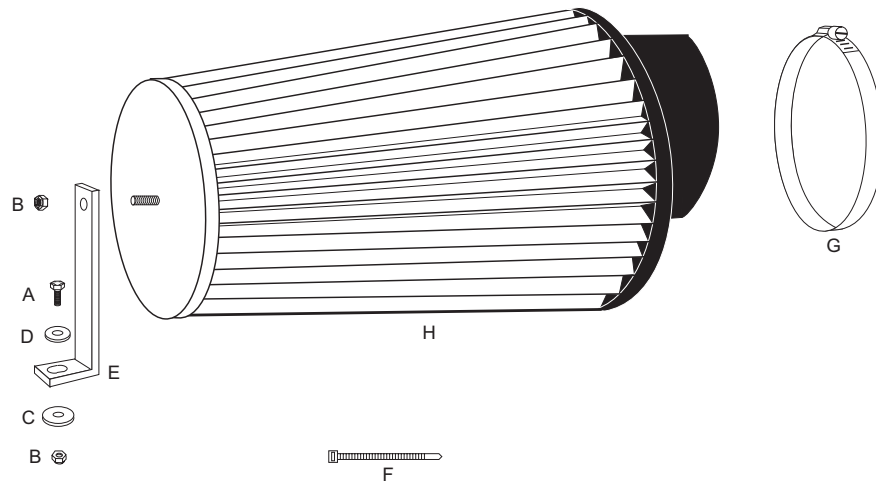

PARTS LIST:

Desc.	Qty.	Part#
A 1/4-20 x 3/4" hex bolt	1	08386
B 1/4-20 nylock nut	2	07517
C fender washer	1	08160
D flat washer	1	08275
E "L" bracket	1	07928
F zip-tie	1	21589
G size 60 hose clamp	1	08624
H Filtercharger® element	1	RF-1004

NOTE: FAILURE TO FOLLOW INSTALLATION INSTRUCTIONS AND NOT USING THE PROVIDED HARDWARE MAY DAMAGE THE INTAKE TUBE, THROTTLE BODY AND ENGINE.

INSTALLATION

See the figure below for stock part locations.
See the exploded view for finished kit locations.

- 1) Disconnect the vehicle's negative battery cable.
- 2) Loosen the hose clamp on the intake hose at the mass-air sensor.
- 3) Un-bolt the airbox assembly from the body, it is held in place by two bolts. (see fig. 1)
- 4) Carefully remove the airbox and the intake hose as a complete unit.
- 5) Bolt "L" bracket to filter, using a supplied nylock. Do not tighten at this time.
- 6) Install the K&N Filtercharger® on to the mass-air sensor. It may be necessary to zip-tie the small plastic hose to keep it from rubbing on the filter. The "L" bracket will line up with an unused hole in the fenderwell. **Note:** the hole may need to be enlarged slightly for the bolt to fit. (see fig. 2)
- 7) Secure the bracket to the fenderwell with the provided hardware. Do not tighten at this time.
- 8) Rotate the K&N Filtercharger® for best clearance, tighten hose clamp and the remaining hardware.

These two bolts hold the airbox.

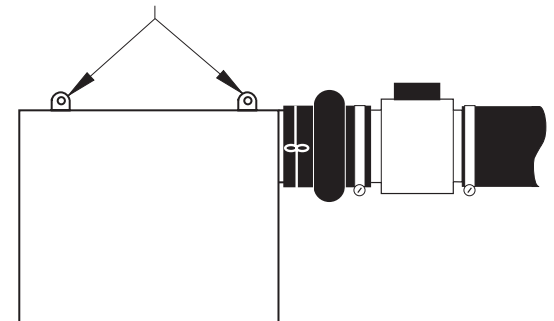

fig. 1

ROAD TESTING

Start the engine with the transmission in neutral or park, and the emergency brake on. Listen for any air leaks or odd noises. If there are air leaks, make sure the hose connections are secure. If there are any odd noises, check for the cause and repair before proceeding. The K&N Filtercharger® Injection Performance Kit will function identically to the factory air filter with the exception of being slightly louder than stock and much more responsive. If all preliminary checks are okay, then a road test is necessary. Listen carefully for rattling or other odd noises and fix as necessary. If the road test is fine, you can enjoy driving as normal with the added response and power. We suggest that the Filtercharger® element be checked periodically for dirt. This is now very easy due to the open element configuration. If the filter material is overly dirty, service it according to the instructions that are in the Recharger service kit, part number 99-5050 or 99-5000. If you have any questions or problems, inquire at your nearest K&N dealer, or direct to K&N Engineering at (909) 684-9762.

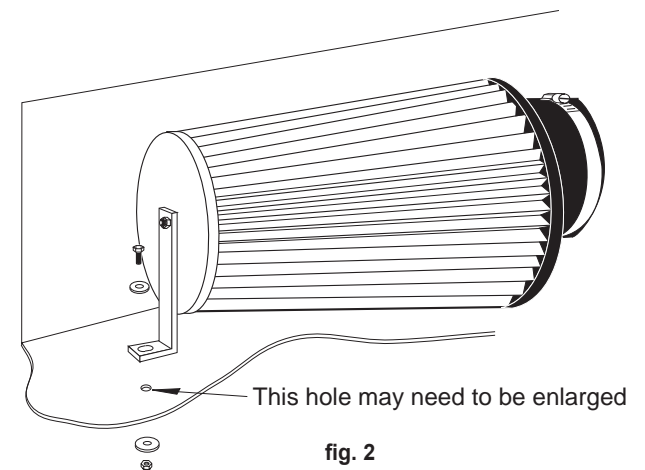
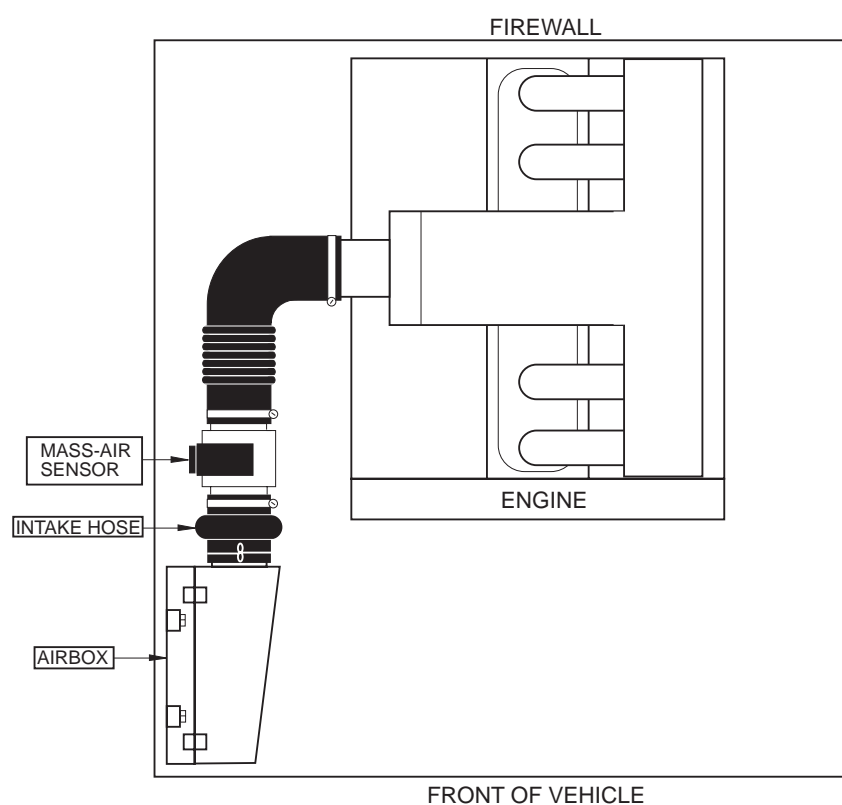

fig. 2

MUSTANG 5.0 ENGINE COMPARTMENT



Refer to this diagram for the location of the various parts listed in the installation instructions.

FREE K&N DECAL To register your warranty please see us online at knfilters.com/register. FREE K&N DECAL