



AIRCHARGER®

INSTALLATION INSTRUCTIONS

57-2510-1

Ford

1995-96 F-Series Pickup L6-4.9L

1994-96 F-Series Pickup V8-5.0L

1995-97 F-Series Pickup V8-5.8L

1994-96 Bronco V8-5.0L

1995-96 Bronco V8-5.8L

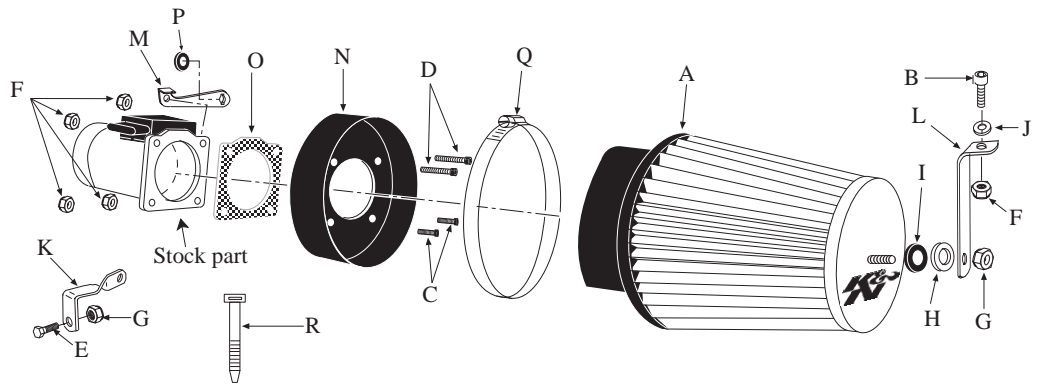

NOTE: This kit was not designed to fit vehicles with a body lift.

TOOLS NEEDED:

Flat Blade Screwdriver
Pair of Vise Grips
5mm Allen Wrench
10mm Wrench
7/16" Wrench
Ratchet
Socket Extension
5/16" Socket
7/16" Socket
Drill
1/4" Drill bit

PARTS LIST:

Desc.	QTY.	Part #	Desc.	QTY.	Part #	Desc.	QTY.	Part #
A. Filtercharger® element	1	RF-1017	G. 1/4-20 nylock nut	2	07517	M. Temperature sensor bracket	1	07107
B. 6mm-1.00 x 16mm allen bolt	1	07818	H. Fender washer	1	08160	N. Mass air adapter	1	08831
C. 6mm-1.00 x 20mm allen bolt	2	07852	I. Rubber washer	1	21685	O. Mass air gasket	1	09330
D. 6mm-1.00 x 25mm allen bolt	2	07859	J. Flat washer	1	08275	P. Temperature sensor gasket	1	09767
E. 1/4-20 x 5/8"L hex bolt	1	08315	K. Twist bracket	1	08018	Q. Hose clamp	1	08697
F. 6mm-1.00 nylock nut	5	07553	L. "L" bracket	1	07091	R. 6" zip tie	1	21591

NOTE: FAILURE TO FOLLOW INSTALLATION INSTRUCTIONS AND NOT USING THE PROVIDED HARDWARE MAY DAMAGE THE INTAKE TUBE, THROTTLE BODY AND ENGINE.

TO START:

1. Turn the ignition OFF and disconnect the vehicle's negative battery cable.

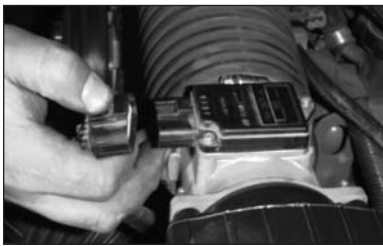

2. Disconnect the vehicle's mass air sensor and air temperature sensor electrical connections.

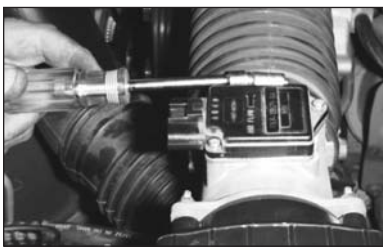

3. Loosen the hose clamp on the intake tube at the mass air sensor.



4. Release the two over center clips and remove the airbox top assembly.



5. Loosen and remove the three bolts that secure the airbox base.



6. Detach the air inlet duct from the airbox base and remove the airbox base.



7. Loosen and remove the four nuts that secure the mass air sensor to the airbox top. Remove the mass air sensor from the airbox top.

NOTE: It may be necessary to use a pair of vise grips to hold the studs while loosening the nuts.

8. Remove the O.E. mass air gasket as it will not be reused.

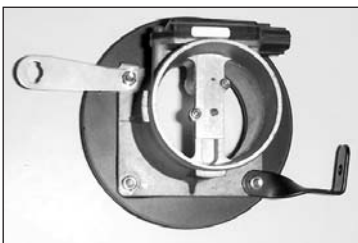

9. Assemble the mass air sensor, mass air adapter, twist bracket and air temperature sensor bracket as shown in the above illustration.

NOTE: Due to the variations in the coolant reservoir support bracket, it may be necessary to mount the twist bracket on the upper or lower hole so that the bracket will line up with the coolant reservoir support bracket.



10. Apply the temperature sensor gasket onto the air temperature sensor bracket.



11. Using the provided hardware, attach the "L" bracket onto the Filtercharger element.



12. Attach the Filtercharger element assembly onto the mass air adapter and secure with hose clamp.



13. Attach the intake tube to the mass air sensor.

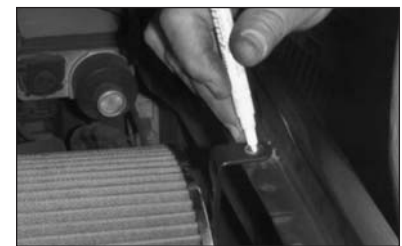

14. Line up the "L" bracket with the fender and mark hole.



15. Line up the twist bracket with the coolant reservoir support bracket and mark hole.

16. For better access to the twist bracket, it may be necessary to loosen and remove the nut that retains the coolant reservoir. Move the coolant reservoir away from its support bracket.

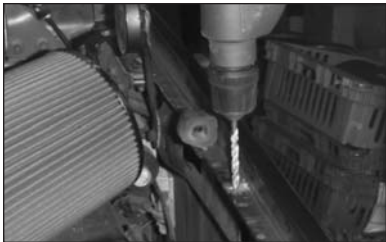

17. Remove the Filtercharger assembly, then drill a hole at the locations marked in step 14 and 15.



18. Drill a hole through the air inlet duct and the inner fender well, then secure using the zip tie provided.



19. Attach the intake tube to the mass air sensor and tighten the hose clamp.

NOTE: For best clearance it may be necessary to bend the original airbox mounting bracket away from the Filtercharger element.

20. Reinstall the coolant reservoir back to its original position and tighten the coolant reservoir retaining nut removed in step 16.

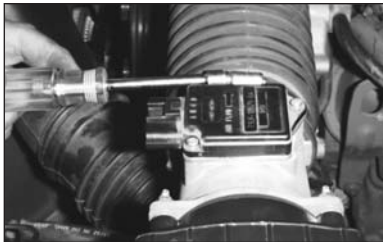

21. Twist the air temperature sensor a 1/4 turn and remove it from the airbox top.

NOTE: Remove the air temperature sensor o-ring as it will not be reused.

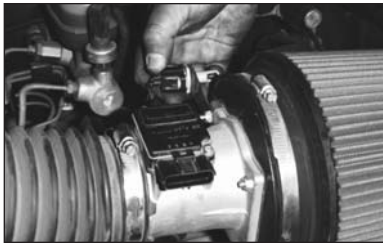

22. Install the air temperature sensor into the air temp sensor bracket and twist a 1/4 turn.

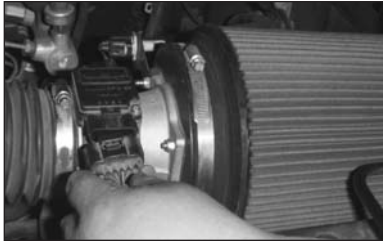

23. Reconnect the mass air sensor and air temperature sensor electrical connection.



24. Reconnect the mass air sensor and air temperature sensor electrical connection.

25. Reconnect the vehicle's negative battery cable. Double check to make sure everything is tight and properly positioned before starting the vehicle.

26. The C.A.R.B. exemption sticker, (attached), must be visible under the hood so that an emissions inspector can see it when the vehicle is required to be tested for emissions. California requires testing every two years, other states may vary.

27. It will be necessary for all FIPK's to be checked periodically for realignment, clearance and tightening of all connections. Failure to follow the above instructions or proper maintenance may void warranty.

ROAD TESTING:

1. Start the engine with the transmission in neutral or park, and the parking brake engaged. Listen for air leaks or odd noises. For air leaks secure hoses and connections. For odd noises, find cause and repair before proceeding. This kit will function identically to the factory system except for being louder and much more responsive.

2. Test drive the vehicle. Listen for odd noises or rattles and fix as necessary.

3. If road test is fine, you can now enjoy the added power and performance from your kit.

4. K&N suggests checking the Filtercharger element periodically for excessive dirt build-up. When the element becomes covered in dirt (or once a year), service it according to the instructions on the Recharger service kit, part number 99-5050 or 99-5000.