



AIRCHARGER®
HIGH-FLOW INTAKE KITS

INSTALLATION INSTRUCTIONS

63-1551

CHRYSLER
2007 PT CRUISER
L4-2.4L TURBO

NOTE: This kit was not designed to fit vehicles with a body lift.

TOOLS NEEDED:

- Flat Blade Screwdriver
- 10mm Wrench
- 13mm Wrench
- 14mm Socket
- Extension
- Ratchet

NOTE: FAILURE TO FOLLOW INSTALLATION INSTRUCTIONS AND NOT USING THE PROVIDED HARDWARE MAY DAMAGE THE INTAKE TUBE, THROTTLE BODY AND ENGINE.

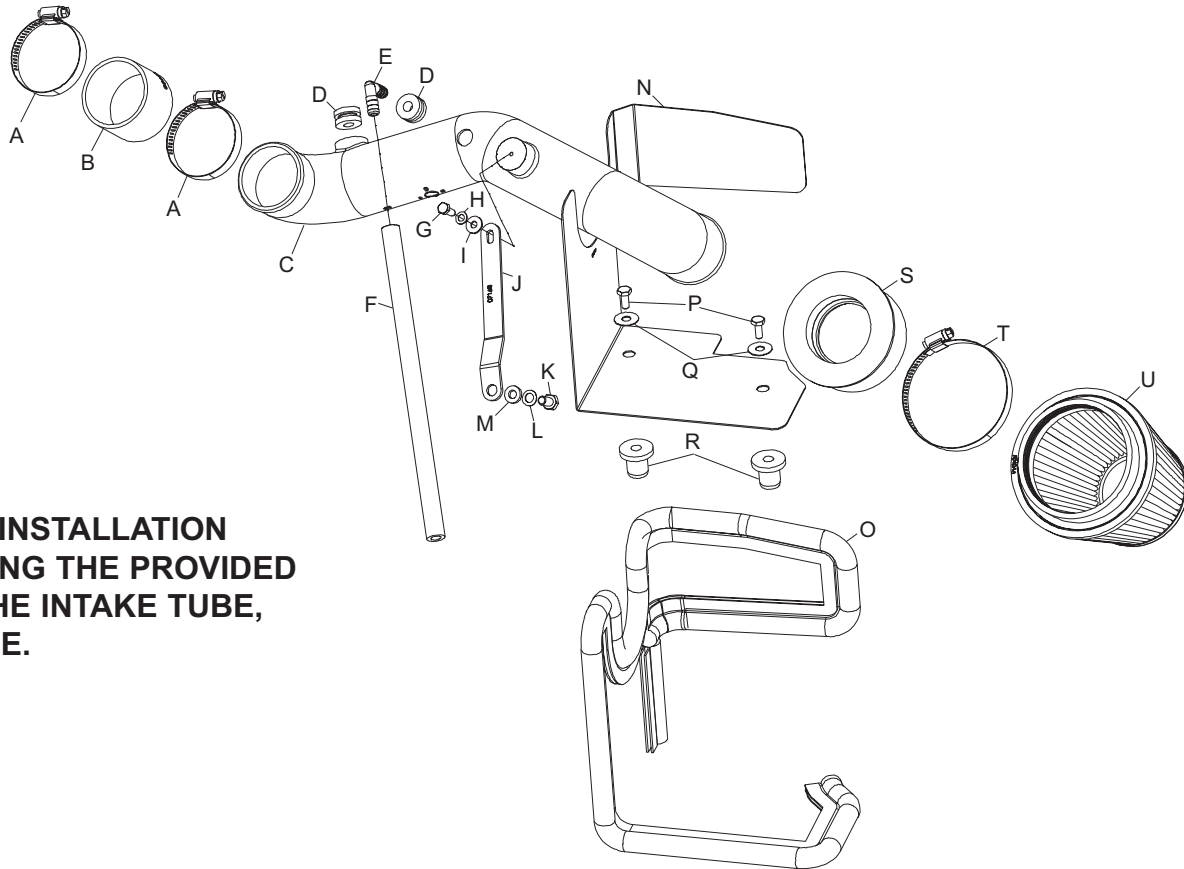

PARTS LIST:

Desc.	Qty.	Part #						
A Hose Clamp #36	2	08530	H Washer; 6mm wave	1	08174	O Edge trim (55")	1	102480
B Hose; 2-3/8"ID X 2"L, silicone	1	08405	I Washer; 1/4"ID X 5/8"OD - sae	1	08275	P Bolt; 3/8"-16 X 1-1/4"L SS hex head	2	07779
C Intake tube (CQ)	1	087083	J Bracket; 57-1531, mild stl, FB/PC	1	07168	Q Washer; 3/8" Flat Washer, SS	2	08134
D Grommet; 15/16"OD, 3/8"ID, 17/32"thk	2	08100	K Bolt; 8MM-1.25 X 16MM, hexhead	1	07844	R Insert; 3/8-16 X 3/400 X 15/16L,	2	08163
E Vent; 90deg, 3/8 X 3/8, plastic	1	08121	L Washer; 8mm spring (wave)	1	08239	S Adapter; 57-3513, 2.5"ID, 4"OD	1	088005
F Hose; 3/8"ID X 12"L, silicone	1	08412	M Washer; 5/16"ID X 5/8"OD, flat	1	08276	T Hose Clamp #64	1	08648
G Bolt; M6-1.00 X 16MM hex hd.	1	07703	N Heat shield	1	07324	U Air Filter	1	RP-4660

TO START:

1. Turn the ignition OFF and disconnect the vehicle's negative battery cable.



2. Loosen hose clamp at the air box, then remove intake tube from the air box as shown.



3. Lift firmly up on the air box to remove from car, then disconnect the crank case vent from the air box.

NOTE: K&N recommends that customers do not discard your factory air intake.



4. Loosen hose clamp at the turbo then remove the intake tube from the vehicle.



5. Disconnect the vacuum line from the intake tube as shown.



6. Disconnect the crank case vent line from the valve cover as shown.



7. Remove the two air box grommets from the stock air box mounting tray.



8. Install the new bracket onto the cylinder head with the provided hardware.



9. Install the two rubber nut inserts into air box grommet holes as shown.



10. Install the edge trim onto the heat shield as shown. Trim if needed.



11. Install the heat shield onto the vehicle with the provided hardware as shown.



12. Install the provided silicone hose (08405) onto the turbo inlet as shown with the provided hose clamp.

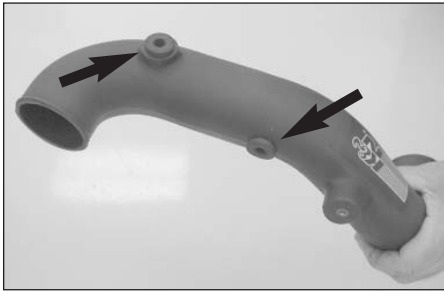

13. Install the two provided grommets onto the intake tube as shown.

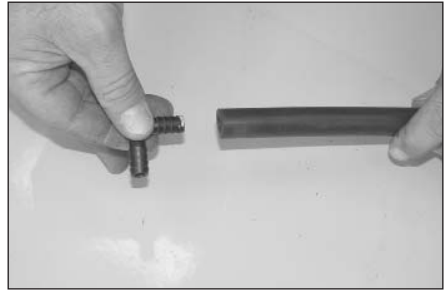

14. Install the 90 deg vent fitting onto the provided silicone hose as shown.



15. Connect the silicone hose with vent fitting on the valve cover as shown.

Note: Fitting is under intercooler hose.



16. Reconnect the two vent fittings onto the new intake tube as shown.

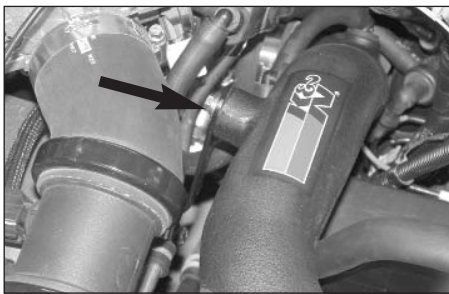

17. Connect the new intake tube onto the turbo inlet with the provided hose clamp. Then connect the intake tube to the bracket on the cylinder head as shown.



18. Install the air filter adaptor onto the intake tube as shown.



19. Install the air filter onto the intake tube as shown.



20. Reconnect the vehicle's negative battery cable. Double check to make sure everything is tight and properly positioned before starting the vehicle.

21. The C.A.R.B. exemption sticker, (attached), must be visible under the hood so that an emissions inspector can see it when the vehicle is required to be tested for emissions. California requires testing every two years, other states may vary.

22. It will be necessary for all Aircharger's to be checked periodically for realignment, clearance and tightening of all connections. Failure to follow the above instructions or proper maintenance may void warranty.

ROAD TESTING:

1. Start the engine with the transmission in neutral or park, and the parking brake engaged. Listen for air leaks or odd noises. For air leaks secure hoses and connections. For odd noises, find cause and repair before proceeding. This kit will function identically to the factory system except for being louder and much more responsive.
2. Test drive the vehicle. Listen for odd noises or rattles and fix as necessary.
3. If road test is fine, you can now enjoy the added power and performance from your kit.
4. K&N suggests checking the air filter element periodically for excessive dirt build-up. When the element becomes covered in dirt (or once a year), service it according to the instructions on the Recharger service kit, part number 99-5050 or 99-5000.