



AIRCHARGER®

HIGH-FLOW INTAKE KITS

NOT LEGAL FOR SALE OR USE ON ANY POLLUTION CONTROLLED MOTOR VEHICLE IN CALIFORNIA OR STATES ADOPTING CALIFORNIA EMISSION PROCEDURES.
See knfilters.com for CARB status on each part for a specific vehicle

INSTALLATION INSTRUCTIONS

63-3113
CHEVROLET / GMC
2019-20 SILVERADO / SIERRA
2.7L

TOOLS NEEDED:

- Ratchet
- Extension
- 10mm deep socket
- 3mm allen key
- 4mm allen key
- t10 torx
- t20 torx
- Phillips screw driver
- Flat blade screw driver
- pick

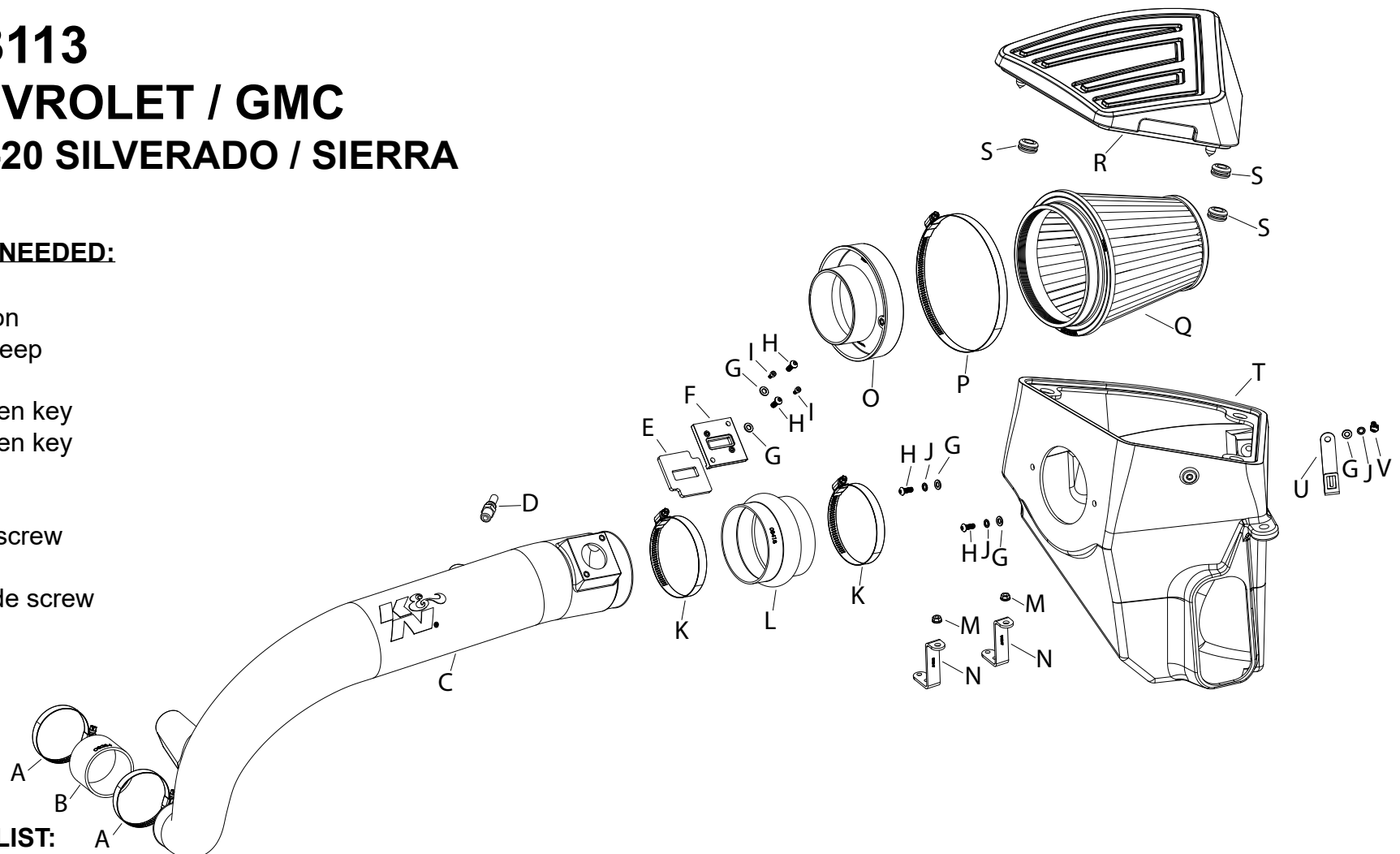

PARTS LIST:

Description	Qty.	Part #	Description	Qty.	Part #	Description	Qty.	Part #
A HOSE CLAMP #40	2	08554	I BOLT; M4.7 X 8MM, A/H CAP	2	07733	Q AIR FILTER	1	RF-10410
B HOSE; 2.5"ID X 2"L	1	08284	J WASHER, M6 SPLIT LOCK ZINC	3	1-3025	R LID; FIPK	1	087420
C TUBE; AIRCHARGER	1	087437	K HOSE CLAMP #64	2	08645	S GROMMET; 1"OD, 1/2"ID	3	08064
D VENT; STRT 1/4" NPT	1	08938	L HOSE; HUMP 4"ID X 3"L	1	08418	T AIRBOX	1	087419
E GASKET; 3/16" PORON	1	09069	M NUT; M6, HEX, SERRATED	2	444.460.04	U BRACKET; STL, TB/PC	1	064358
F ADAPTOR; NYLON 6/6 GF	1	21515-1	N BRACKET; "Z"	2	010047	V BOLT; M6 X 1.00 X 12MM	1	07727
G WASHER; 6MM FLAT	5	08269	O ADAPTER #454	1	27300			
H BOLT; M6 X 1.00 X 16MM	4	07730	P HOSE CLAMP #104	1	08697			

If you need any assistance please call 1-800-858-3333 to speak with a representative in our Customer Service Center before returning the product.

NOTE: FAILURE TO FOLLOW INSTALLATION INSTRUCTIONS AND NOT USING THE PROVIDED HARDWARE MAY DAMAGE THE INTAKE TUBE, THROTTLE BODY AND ENGINE.

TO START:

1. Turn off the ignition and disconnect the negative battery cable.
NOTE: Disconnecting the negative battery cable erases pre-programmed electronic memories. Write down all memory settings before disconnecting the negative battery cable. Some radios will require an anti-theft code to be entered after the battery is reconnected. The anti-theft code is typically supplied with your owner's manual. In the event your vehicles anti-theft code cannot be recovered, contact an authorized dealership to obtain your vehicles anti-theft code.



2. Disconnect the mass air sensor electrical connection and loosen the hose clamp that secures the factory intake tube to the air filter housing.



3. Depress the locking tab and then disconnect the CCV pipe from the plenum.



4. Depress the locking tap and then disconnect the CCV pipe from the solenoid attached to the factory intake tube. Disconnect the solenoid electrical connection.



5. Loosen the hose clamp that secures intake tube to the turbo inlet.



6. Remove the two bolts that secure the engine cover to the engine and then remove the cover from the vehicle. These bolts will be reused in a later step.



7. Remove the two nuts that secure the intake tube to the engine. Unhook the wiring harness from the intake tube and then remove the intake tube assembly from the vehicle. These nuts will be reused in a later step.



8. Remove the two bolts that secure the hood release latch handle and then remove the handle from the vehicle.



9. Remove the ten push pins that secure the upper radiator valence and then remove the valence from the vehicle.



10. Remove the push pin that secures the fresh air duct to the core support and then dislodge the duct from the air filter housing. This push pin will be reused in a later step.



11. Using a small pick or similar tool, release the locking tab that secures the wiring harness bulk connector to the air filter housing and then remove the harness from the housing.



12. Remove the nut that secures the air filter housing to the mounting bracket. This nut will be reused in a later step.



13. Install the provided bulk connector bracket onto the K&N air filter housing and secure with the provided hardware.



14. Install the filter adapter into the K&N filter housing and secure with the provided hardware.



15. Remove both factory air filter housing bushings from the factory housing and install them onto the K&N filter housing as shown.

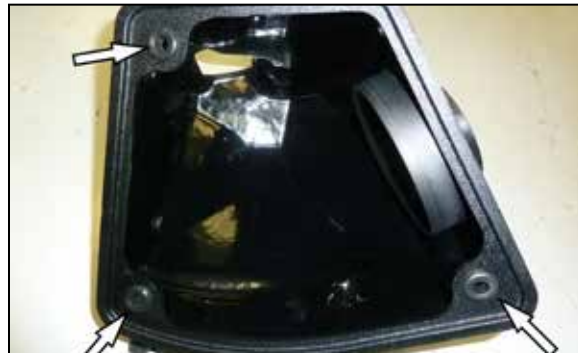

16. Install the three provided grommets into the K&N air filter housing as shown.



17. Install the K&N air filter housing into the vehicle and secure with the factory nut from step #12.



18. Install the fresh air intake duct into the K&N air filter housing and then secure it to the core support using the factory push pin.



19. Install the wiring harness bulk connector onto the bracket installed onto the K&N air filter housing.



20. Install the hump coupler onto the filter adapter and secure with the provided hose clamp.



21. Install the provided straight coupler onto the turbo inlet and secure with the provided hose clamp.



22. Install the provided quick connect fitting into the K&N intake tube.



23. Remove the mass air sensor from the factory housing and then install the sensor into the adapter provided along with the gasket.



24. Install the mass air sensor assembly into the K&N intake tube and secure with the provided hardware as shown in the photo.



25. Remove the CCV solenoid from the factory intake tube and install it into the K&N intake tube using the factory bolt.



26. Install the intake tube assembly into the coupler at the air filter housing and then into the coupler at the turbo inlet, adjust the tube for best fit and then secure with the provided hose clamps.



27. Using the factory bolts and the nuts provided, secure the two provided "Z" brackets to the engine cover as shown.



28. Install the engine cover onto the engine and secure the brackets to the factory mounting studs using the factory nuts.



29. Connect the CCV tube to the quick connect fitting installed into the K&N intake tube.



30. Connect the CCV tube to the solenoid and connect the electrical connection.



31. Reconnect the mass air sensor electrical connection.



32. Install the K&N air filter onto the filter adapter and secure with the provided hose clamp.



33. Install the K&N air filter housing lid onto the lower air filter housing.



34. Reinstall the upper radiator valence and secure with the ten factory push pins.



35. Reinstall the hood latch lever and secure with the factory hardware.



36. Reconnect the vehicle's negative battery cable. Double check to make sure everything is tight and properly positioned before starting the vehicle.

37. It will be necessary for all K&N® high flow intake systems to be checked periodically for realignment, clearance and tightening of all connections. Failure to follow the above instructions or proper maintenance may void warranty.

ROAD TESTING:

1. Start the engine with the transmission in neutral or park, and the parking brake engaged. Listen for air leaks or odd noises. For air leaks secure hoses and connections. For odd noises, find cause and repair before proceeding. This kit will function identically to the factory system except for being louder and much more responsive.

2. Test drive the vehicle. Listen for odd noises or rattles and fix as necessary.

3. If road test is fine, you can now enjoy the added power and performance from your kit.

4. K&N Engineering, Inc., requires cleaning the intake system's air filter element every 100,000 miles. When used in dusty or off-road environments, our filters will require cleaning more often. We recommend that you visually inspect your filter once every 25,000 miles to determine if the screen is still visible. When the screen is no longer visible some place on the filter element, it is time to clean it. To clean and re-oil, purchase our filter Recharger® service kit, part number 99-5050 or 99-5000 and follow the easy instructions.

NOT LEGAL FOR SALE OR USE ON ANY POLLUTION CONTROLLED MOTOR VEHICLE IN CALIFORNIA OR STATES ADOPTING CALIFORNIA EMISSION PROCEDURES.

See knfilters.com for CARB status on each part for a specific vehicle

* FREE K&N® decal To register your warranty, please see us online at knfilters.com/register. FREE K&N® decal *