



INSTALLATION INSTRUCTIONS

66-3210

Holley 4 barrel with choke tower

Congratulations, you have purchased the finest air intake kit that money can buy. The following procedure **MUST** be followed to ensure proper performance and seal of the K&N X-Stream Flow Control Assembly. Failure to follow any of these steps **CAN** result in the X-Stream's top warranty becoming void

CAUTION: It is imperative that no part of the X-Stream® top comes into contact with anything on the vehicle at any time. If the X-Stream® top rubs against anything it might become irreparably damaged. Double check measurements to verify that no interference will occur **BEFORE** closing the hood.

Step 1 Thread the all-thread stud into the carburetor until it bottoms out. Secure with jam nut. **NOTE:** If your carburetor has a 5/16" x 18" stud boss, use the provided 5/16 to 1/4" adapter.

Step 2 Install the Flow Control base over the bowl vents.

Step 3 Install the K&N Filtercharger making sure it is fully seated in base.

Step 4 Thread nylock nut onto stud.

Step 5 Lay a straight edge across the top of the Filtercharger element. Adjust the nylock until the top of it is three turns below the bottom of the straight edge.

Step 6 Remove the stud and cut it 1-1/4" above the nylock. De-burr the end of the stud and make sure the nut threads on smoothly.

Step 7 Re-install the stud making sure the nylock is still 3 turns below the straight edge.

Step 8 Place the metal washer over the stud

Step 9 Install the X-Stream Top making sure it is fully seated on the Filtercharger all the way around.

Step 10 Install rubber washer.

Step 11 Install metal washer.

Step 12 Install nylock nut - It should become tight 1-1/2 to 2 turns after contacting the flat washer.

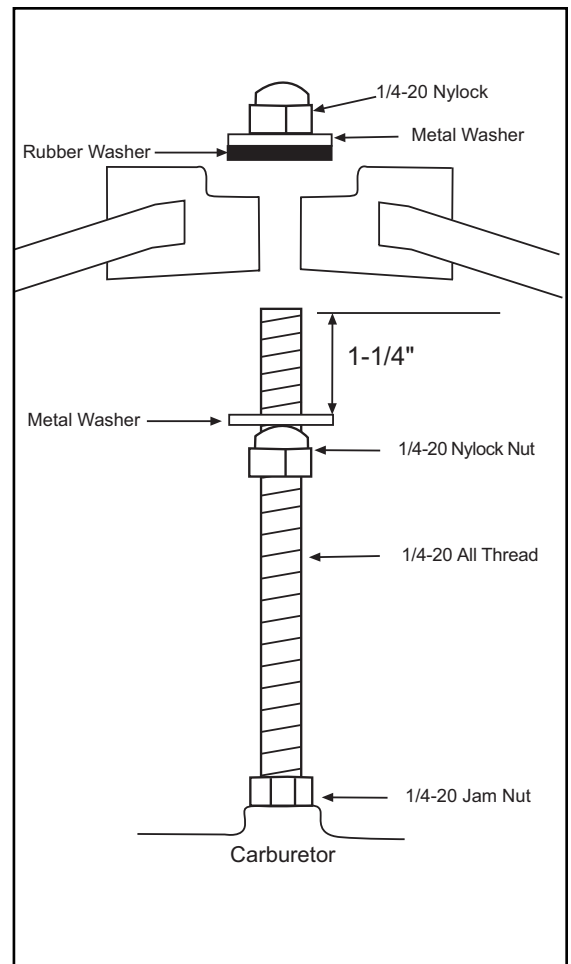

NOTE: Due to the air flow increase, we recommend that you consult with your engine builder or an experienced carburetor builder for jetting recommendation.