



# TYPHOON INTAKE SYSTEMS

## INSTALLATION INSTRUCTIONS

69-3514

**Ford**  
**2006-08 Fusion**  
**I4-2.3L**

**Tools:**

Ratchet, Extension, 10mm  
 Socket, 8mm Socket,  
 10mm Wrench, 3mm Allen  
 Wrench, Flat Blade Screw  
 Driver, Phillips Screw  
 Driver.

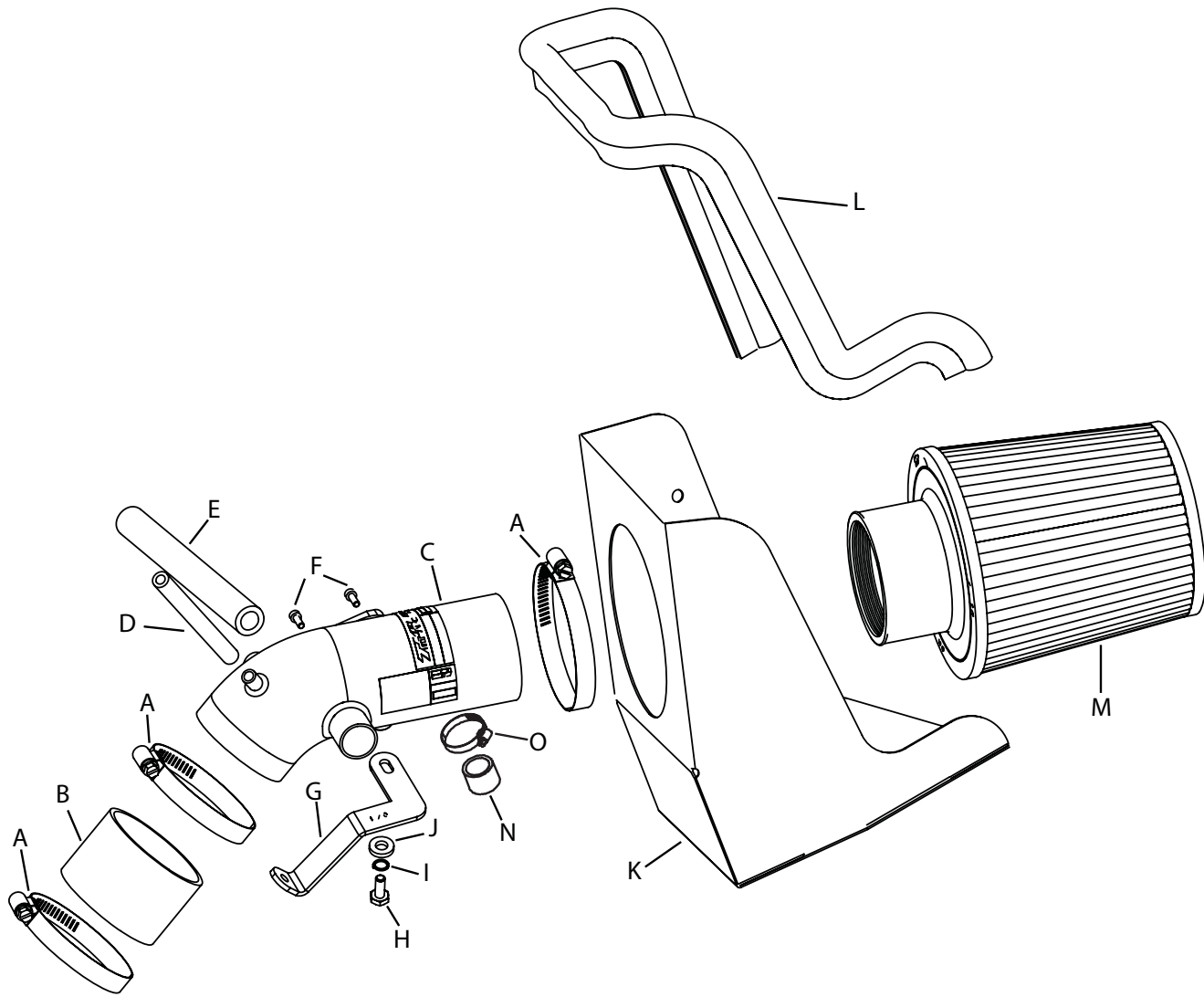

Description	Qty.	Part #	Description	Qty.	Part #	Description	Qty.	Part #
A	3	08577	F	2	07733	K	1	07654
B	1	08440	G	1	06491	L	1	102496
C	1	27531	H	1	07812	M	1	RU-4960
D	1	08716	I	1	08198	N	1	08246
E	1	08159	J	1	08275	O	1	08413

**NOTE: FAILURE TO FOLLOW INSTALLATION INSTRUCTIONS AND NOT USING THE PROVIDED HARDWARE MAY DAMAGE THE INTAKE TUBE, THROTTLE BODY AND ENGINE.**

**TO START:**

1. Turn the ignition OFF and disconnect the vehicle's negative battery cable.

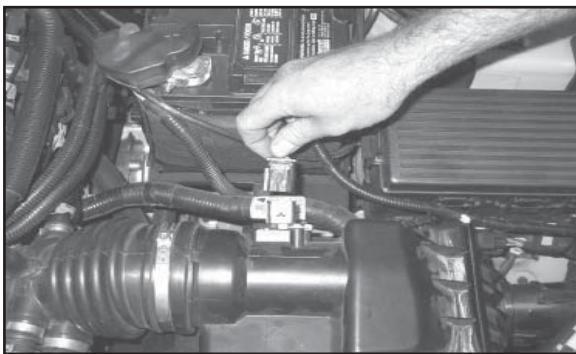

2. Release the red locking clip, then disconnect the mass air sensor electrical connection.

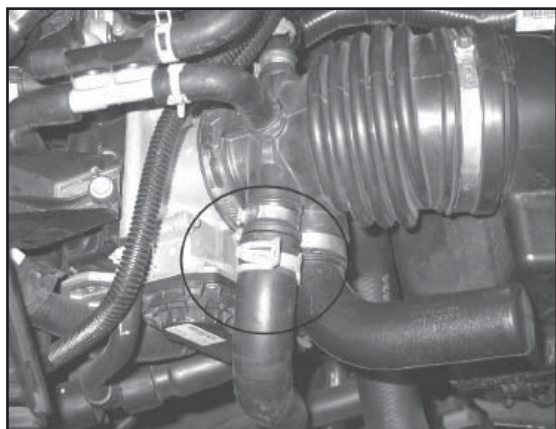

3. On vehicles equipped with an air injection pump, using pliers, release the spring clamp that fastens the air injection hose to the factory intake tube, then disconnect the air injection hose from the intake tube.

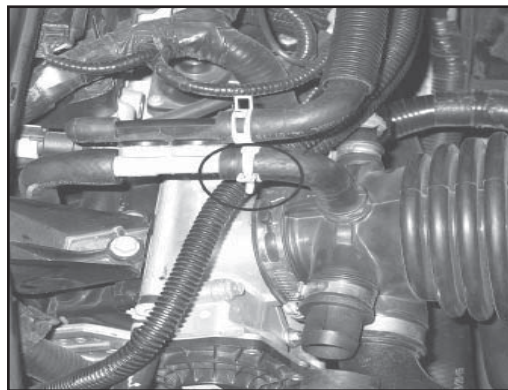

4. Release the spring clamp, then disconnect the solenoid valve hose from the stock plastic fitting.

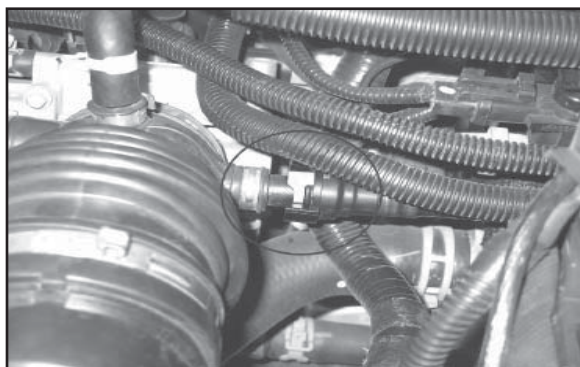

5. Release the green locking ring, then disconnect the crank case vent hose from the stock intake tube

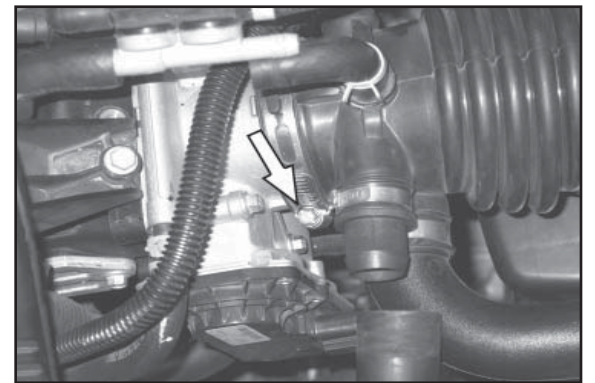

6. Loosen the hose clamp that fastens the stock intake tube to the throttle body.

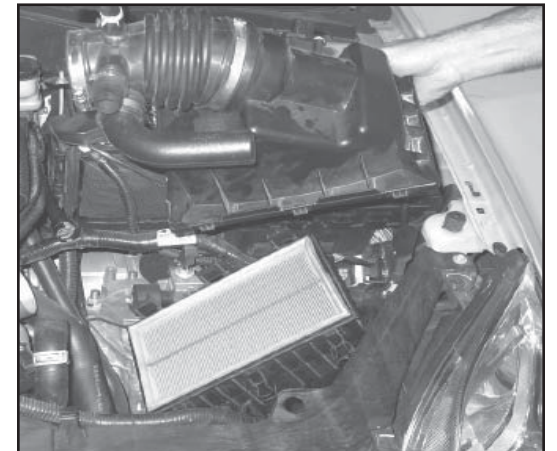

7. Release the three upper air box retaining clips, then remove the upper air box and intake tube assembly.



8. Firmly pull the lower air box upwards to dislodge it from the mounting grommets; remove the lower air box.  
**NOTE: K&N recommends that you do not discard your factory air intake.**

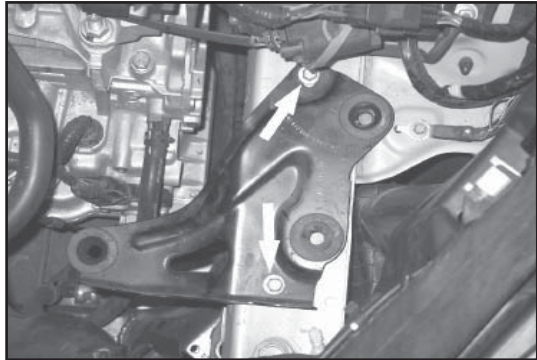

9. Remove the two bolts that fasten the air box mounting bracket to the inner fender, then remove the mounting bracket.  
**Note: Mounting bolts will be re-used.**

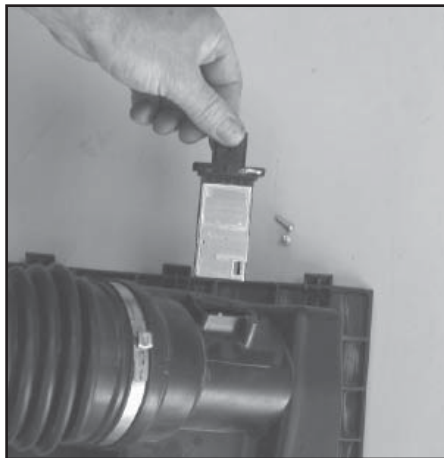

10. Remove the two screws that fasten the mass air sensor to the factory air box, then remove the mass air sensor.

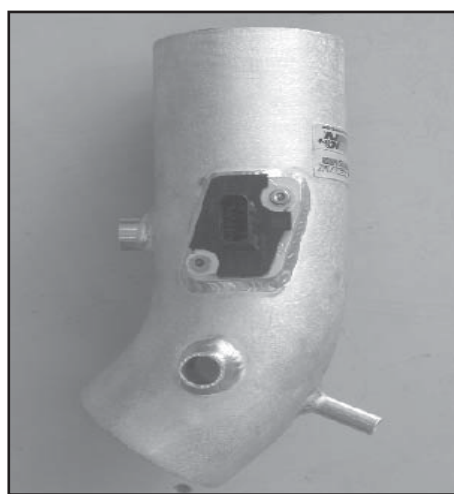

11. Install the mass air sensor into the K&N intake tube using the provided hardware.



12. Disconnect the crank case vent hose from the valve cover, remove it, and place it on a surface suitable for cutting. Using a razor blade or knife; cut the crank case vent hose as shown.



13. Install the supplied silicone vent hose onto the cut end of the stock crank case vent hose.

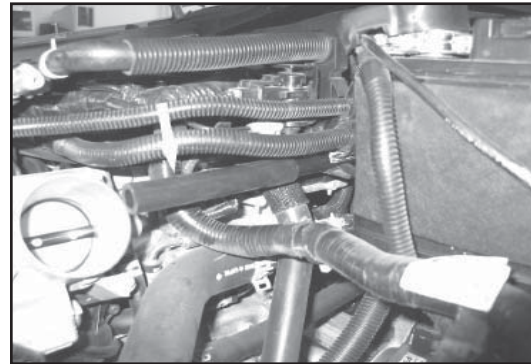

14. Re-install the modified crank case vent hose, then fasten using the stock retaining clip.

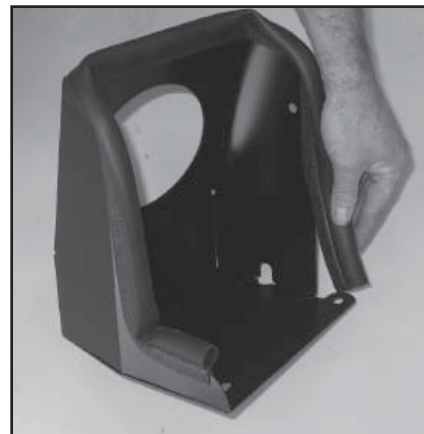

15. Install the provided edge trim onto the heat shield.  
**Note: Some trimming of the edge trim will be needed.**



16. Place the heat shield into position in the inner fender well, then fasten using the stock bolts removed in step # 9.

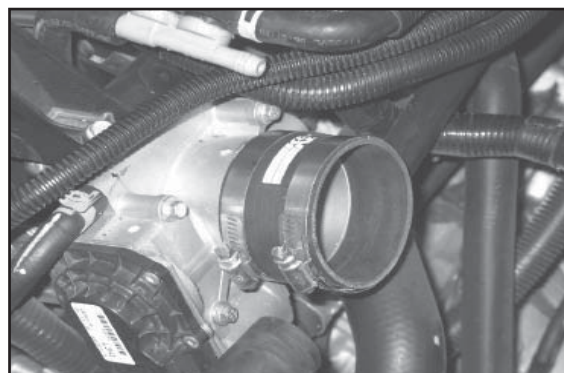

17. Install the provided silicone hose (08440) onto the throttle body and fasten using the provided hose clamp.

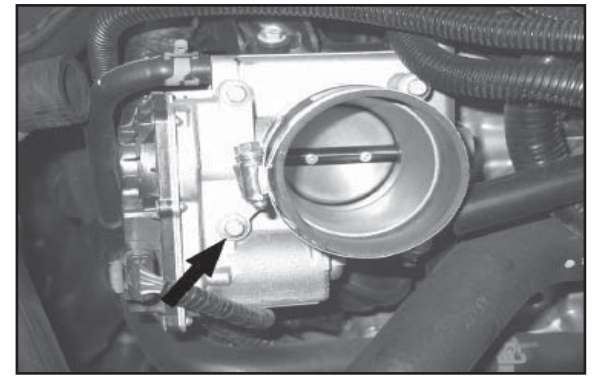

18. Remove the lower throttle body bolt.  
**Note: Bolt will be Re-used.**

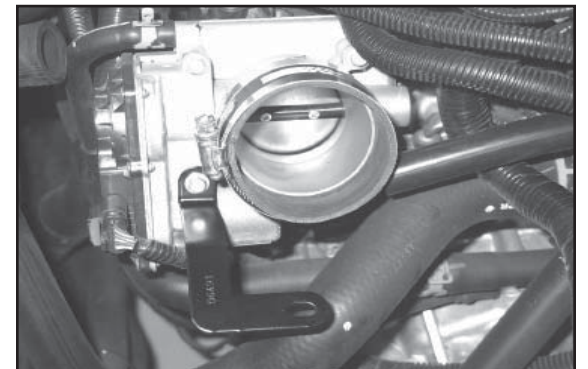

19. Install the intake tube mounting bracket and fasten using the factory bolt removed in step # 18.

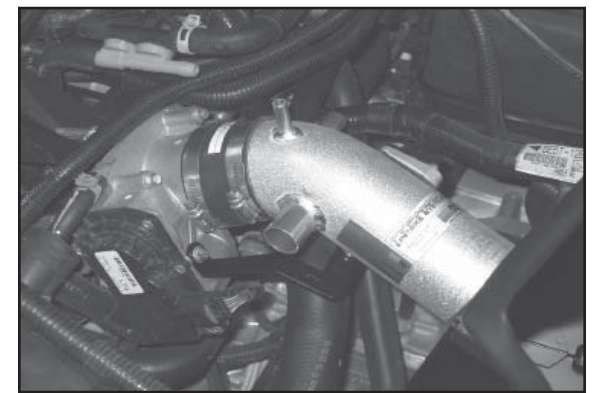

20. Install the K&N intake tube into the silicone hose (08440) and align the intake tube fastening location with the intake tube mounting bracket (06491.) Fasten using the provided hose clamp and mounting bracket hardware.

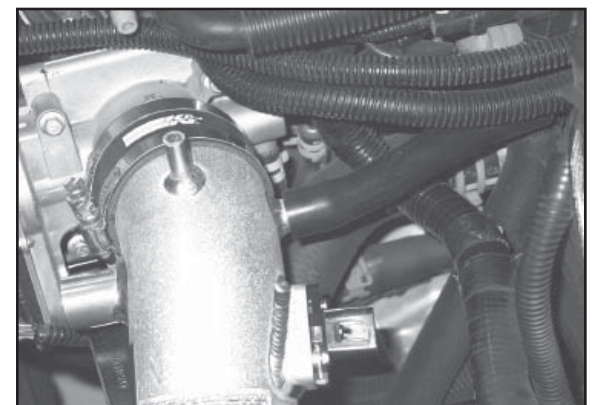

21. Connect the crank case vent hose to the K&N intake tube.  
**Note: Some trimming of the crank case vent hose may be necessary.**

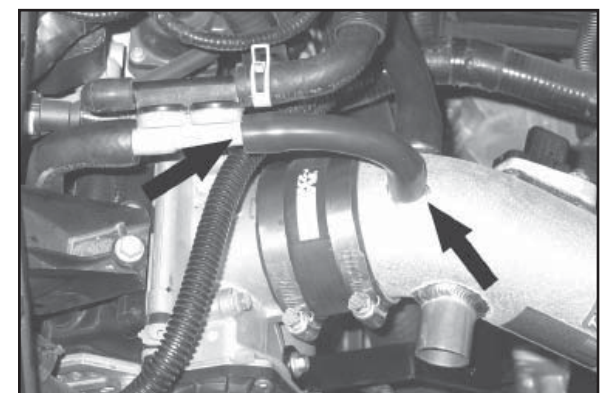

22. Connect the provided silicone solenoid valve hose to the stock fitting and K&N intake tube fitting.

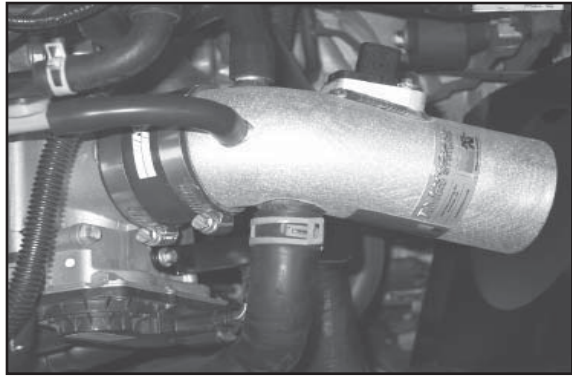

23. Connect the stock air injection hose to the fitting on the K&N intake tube, then fasten using the stock spring clamp.

**Note: On vehicles not equipped with an air injection pump, install the supplied 1" I.D. black caplug to the fitting on the K&N intake tube. Secure with the provided hose clamp.**

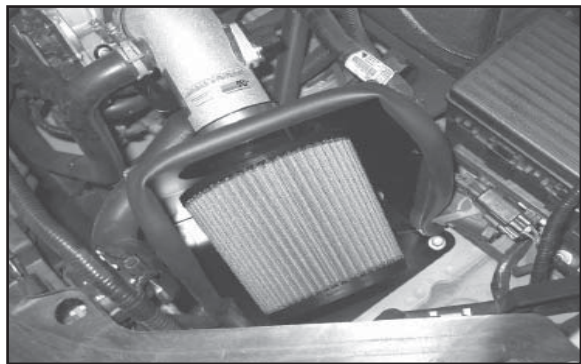

24. Install the K&N air filter onto the intake tube and fasten using the provided hose clamp.

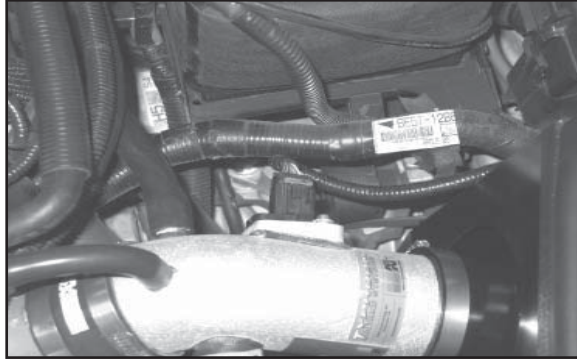

25. Re-connect the mass air sensor electrical connection.

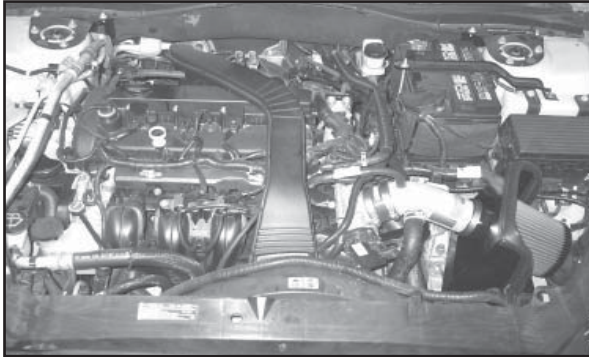

26. Reconnect the negative battery cable.

27. It will be necessary for all Typhoons to be checked periodically for re-alignment, clearance, and tightening of all connections. Failure to follow the above instructions and/or improper maintenance may void warranty.

#### ROAD TESTING:

1. Start the engine with the transmission in neutral or park, and the parking brake engaged. Listen for air leaks or odd noises. For air leaks secure hoses and connections. For odd noises, find cause and repair before proceeding. This kit will function identically to the factory system except for being louder and much more responsive.

2. Test drive the vehicle. Listen for odd noises or rattles and fix as necessary.

3. If road test is fine, you can now enjoy the added power and performance from your kit.

4. K&N suggests checking the Air Filter element periodically for excessive dirt build-up. When the element becomes covered in dirt (or once a year), service it according to the instructions on the Recharger service kit, part number 99-5000 or 99-5050.

**\*Free K&N Decal! To register your warranty, please see us online at [Knfilters.com/register](http://Knfilters.com/register). Free K&N Decal!\***