

# K&N TYPHOON INTAKE SYSTEMS®

## INSTALLATION INSTRUCTIONS

69-7075

Nissan

1991-94, 240sx (S13)

L4-2.4L DOHC

### TOOLS NEEDED:

4mm Allen Wrench  
8mm Socket  
10mm Socket  
10mm Wrench  
Flat Blade Screwdriver  
Ratchet  
Extension  
Pliers  
Philips Screwdriver

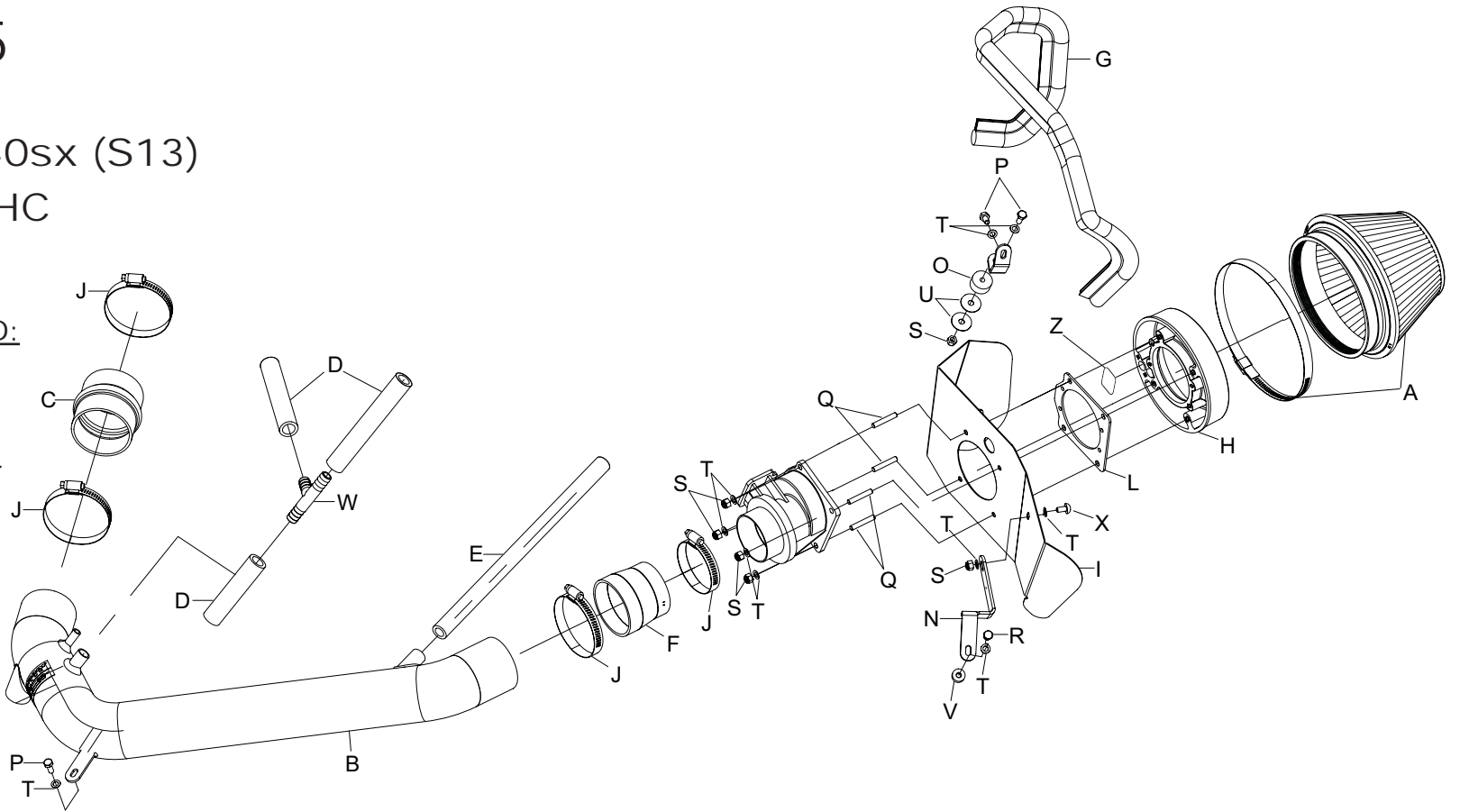

### PARTS LIST:

Desc.	Qty.	Part #					
A AIR FILTER	1	RU-4600	J Hose Clamp #44, SS	3	08560	S Nut; 6mm Nylock, Hexhead, SS	6 07512
B Tube; 2-3/4"OD	1	27522	K Hose Clamp #36	1	08530	T Washer; 6mm Wave, SS	10 08277
C Hose; 2-3/4"ID X 3"L; Hump, Black	1	08439	L Gasket, Neoprene	1	10493	U Washer; 1"D X 1/4 Hole Fender	2 08160
D Hose; 1/2"ID X 14"L, Black Silicone	1	08402	M Bracket; "C", STL, FB/PC	1	020013	V Spacer; .625" OD X .250"ID X .250"L,	1 06555
E Hose; 5/8"ID X 14"L, Black Silicone	1	084083	N Bracket; "Twist", STL, FB/PC	1	020014	W Vent; 1/2" Barbed, "T", Nylon	1 08166
F Hose; 2-1/2" to 2-3/4" TPRD, Black	1	084016	O Stud; Rubber Mnt, M/F, 1/2"L X 1"W	1	070228	X BOLT; M6 X 1.00" 12MM, SS	1 07794
G Edge Trim; 3/4" Bulb Top Lock	1	102498	P Bolt; M6 X 1.00 X 12mm, Hexhead, SS	2	07727	Y Hose Clamp #104	1 08697
H Adaptor, "455"	1	08265	Q Stud; 6MM-1.00 x 35MM L, SS	4	08220	Z Rubber Plug	1 08114
I Heat Shield; STL, FB/PC	1	07342	R Bolt; 6mm - 1.00 X 16mm, SS	2	07812		

**NOTE: FAILURE TO FOLLOW INSTALLATION INSTRUCTIONS AND NOT USING THE PROVIDED HARDWARE MAY DAMAGE THE INTAKE TUBE, THROTTLE BODY AND ENGINE.**

### TO START:

1. Turn off the ignition and disconnect the negative battery.

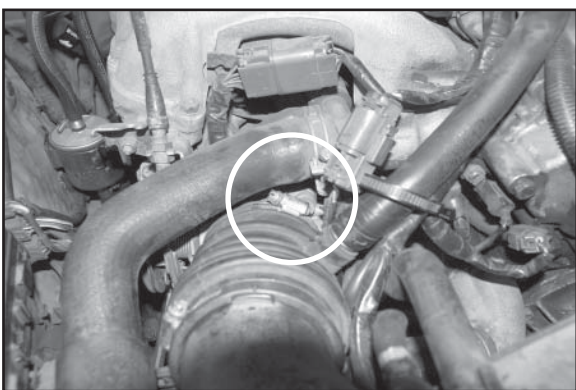

2. Loosen the hose clamp at the throttle body.

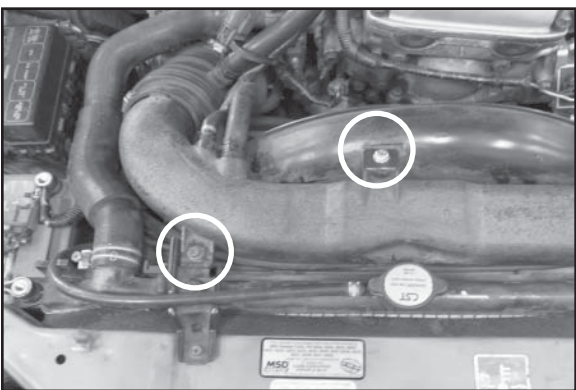

3. Remove 2 bolts that secure factory air intake.

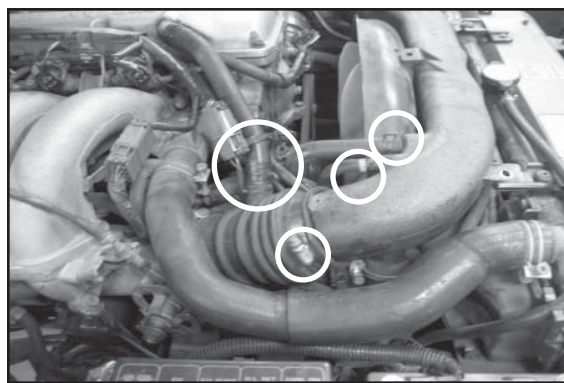

4. With pliers, squeeze hose clamps and disconnect the following hoses: cvc hose; air bypass hose; fresh air switching valve; and loosen the hose clamp on the air reservoir hose. Remove zip tie if present.

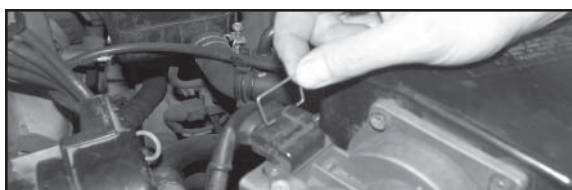

5. Unplug MAF sensor, use flathead screwdriver to remove wire clip.

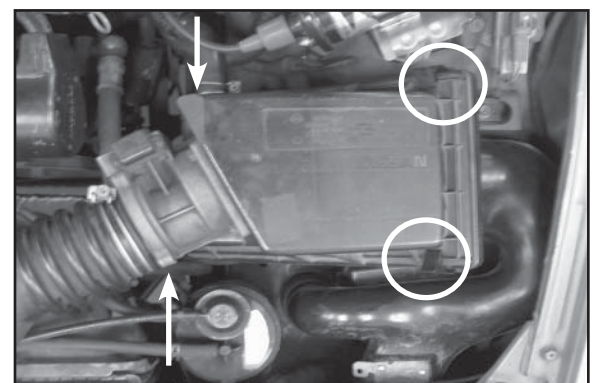

6. Unclip the 4 clips that secure the upper airbox to the lower airbox.

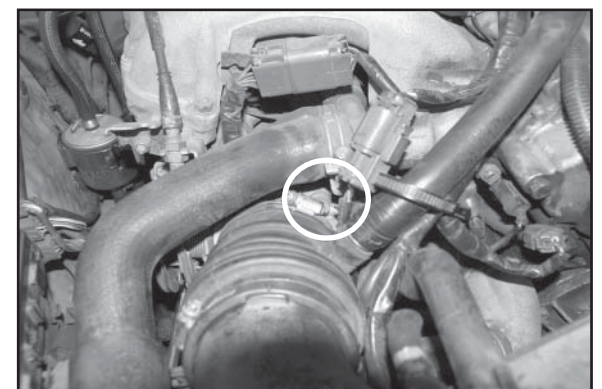

7. Loosen the hose clamp on the air injection hose from the upper airbox.

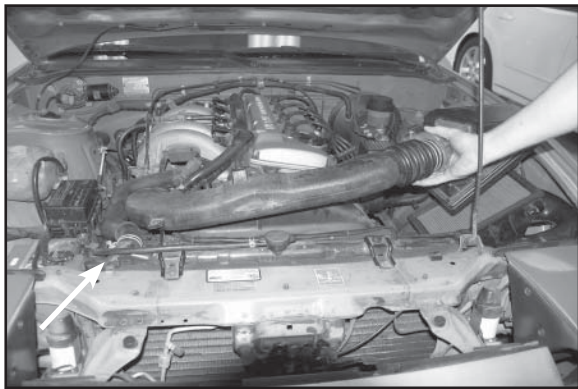

8. Remove factory air intake tube and upper air box. Disconnect the air reservoir hose.

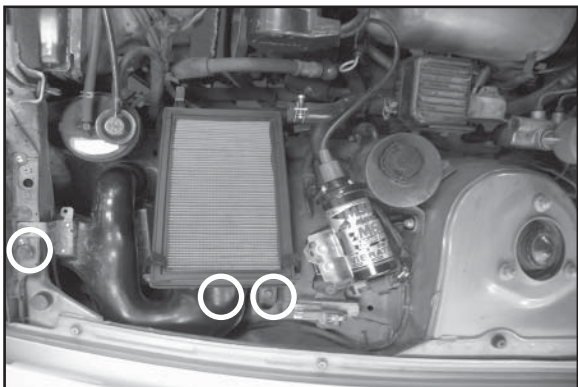

9. Loosen the lower air box mounting bolt and apply light pressure to prevent the bolt from spinning. Then remove the 2 fresh air inlet screws.

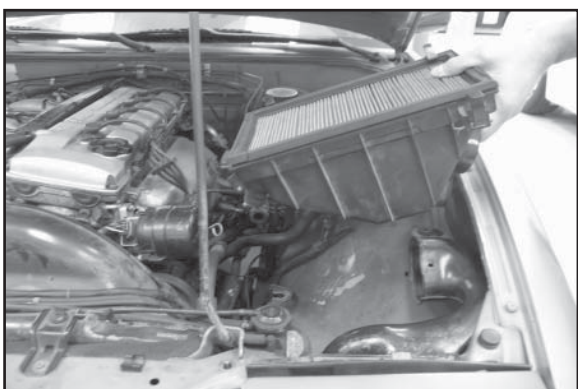

10. Firmly pull up, then push forward to remove the lower airbox.  
**Note: K&N recommends that customers do not discard factory air intake.**

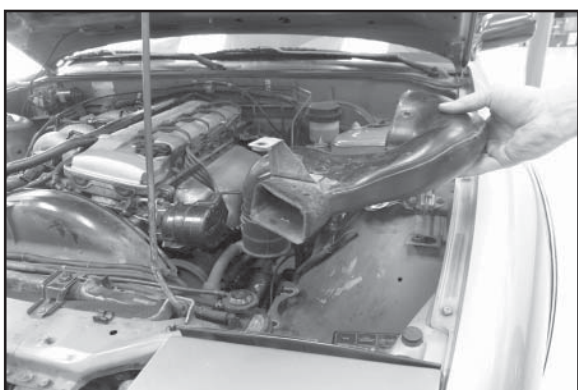

11. Remove the fresh air inlet tube by twisting and lifting upward.

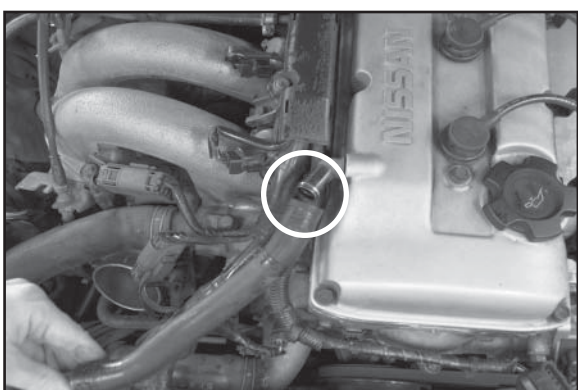

12. Using pliers, unclip the CVC hose and disconnect.

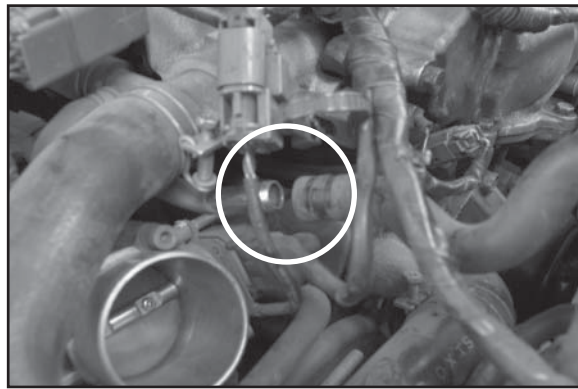

13. Remove the air bypass hose.

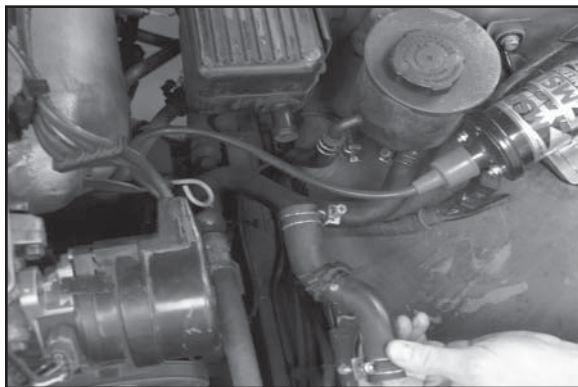

14. Remove the air injection hose by loosening the hose clamp.

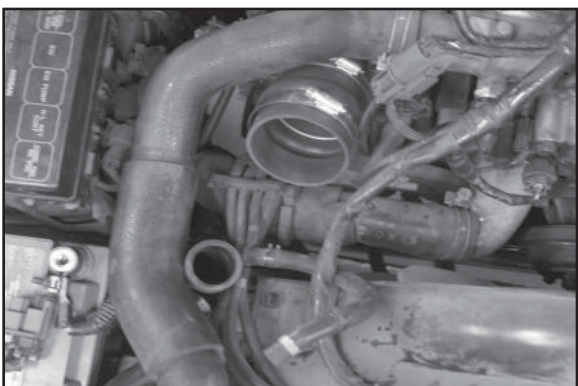

15. Attach the hose clamps to the silicone hose then install on the throttle body.

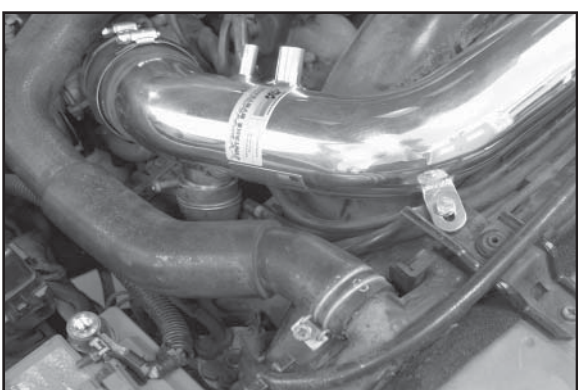

16. Install the K&N intake tube, make sure that the air reservoir is connected at this time. Then install the provided bolt into the threaded hole on the original tube mounting point.

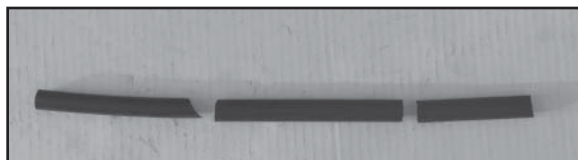

17. Cut the 1/2"ID X 14" silicone hose into three lengths: 5", 3-3/4", 5-1/4"

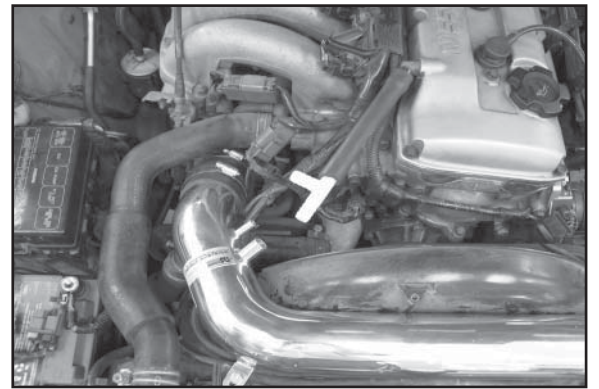

18. Install the 5" hose from the CVC to the plastic "T".

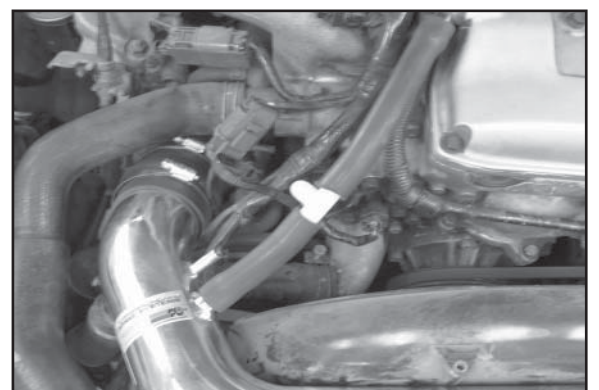

19. Install the 3-3/4" hose to the typhoon tube to the plastic "T".

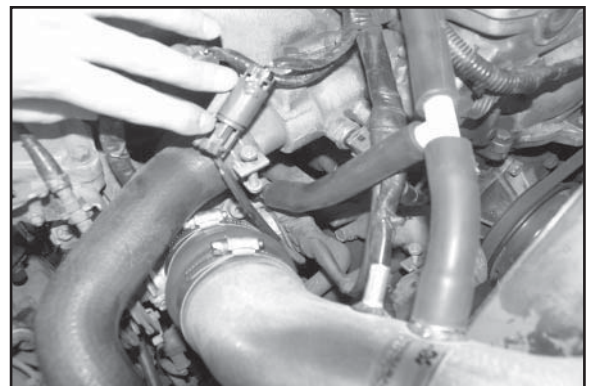

20. Install the 5-3/4" hose from the air bypass to the open point on the plastic "T".

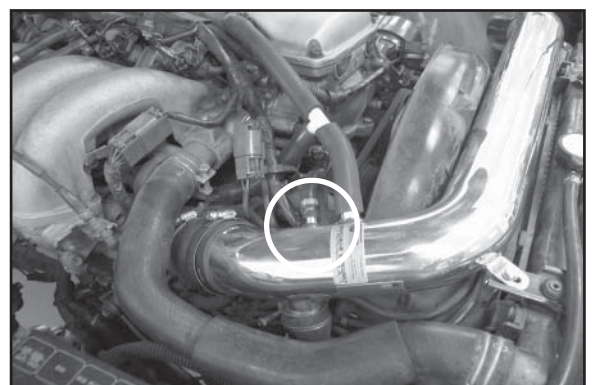

21. Reinstall the fresh air switching valve hose to the typhoon tube. Reattach any



22. On the factory air intake tube, loosen the clamp to remove the MAF to the factory air intake tube.

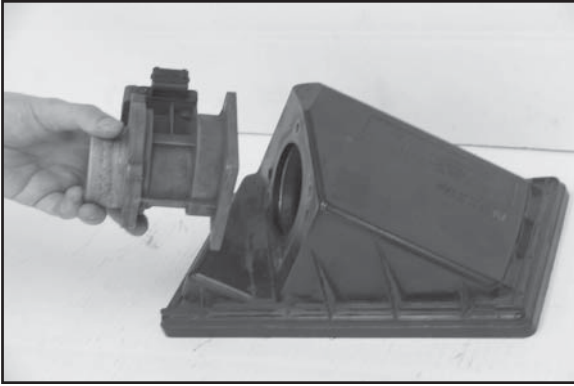

23. Loosen and remove the four bolts that hold the upper air box to the MAF sensor.



24. Install the provided edge trim to the heat shield.

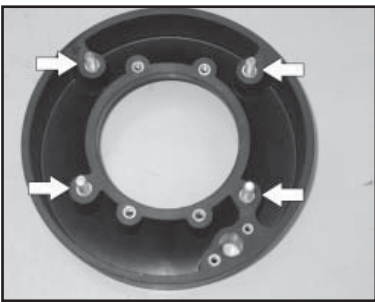

25. Install studs onto provided filter adaptor.

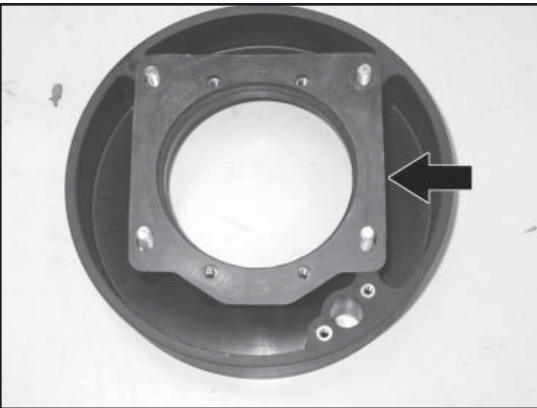

26. Install gasket onto filter adaptor as shown.

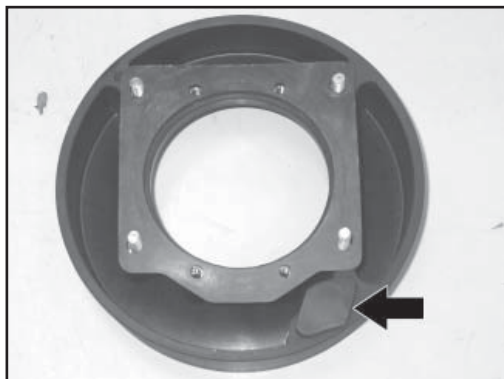

26a. Install the provided plug into the temperature sensor position on the K&N filter adapter as shown.



27. Install adaptor to filter and secure as shown.



28. Install heat shield onto filter assembly as shown.

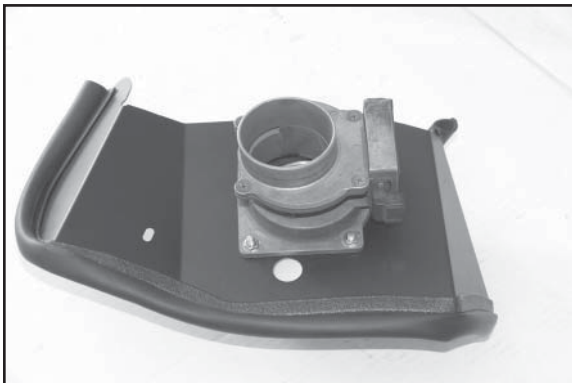

29. Install MAF sensor to the filter assembly as shown and secure with provided hardware.



30. Attach the silicone hose to the MAF sensor with the provided hose clamps.  
**NOTE: The hose clamp ratchets are on the same side as the MAF hookup.**



31. Stack washers around the "C" bracket and secure with rubber mounted stud (Do not tighten completely).



32. Install assembled bracket on lower air box mount.  
**NOTE: The two large washers should sandwich the smaller hole to hold the bracket in place.**

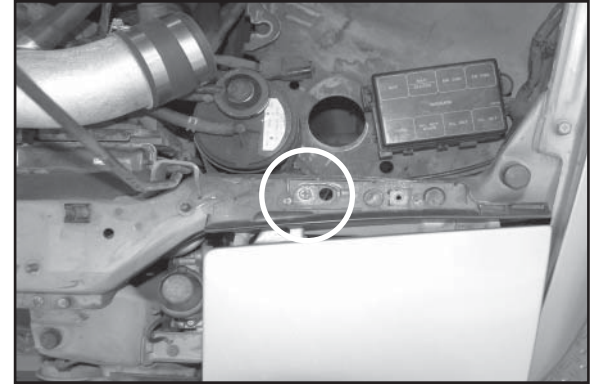

33. Remove the headlight bracket bolt.

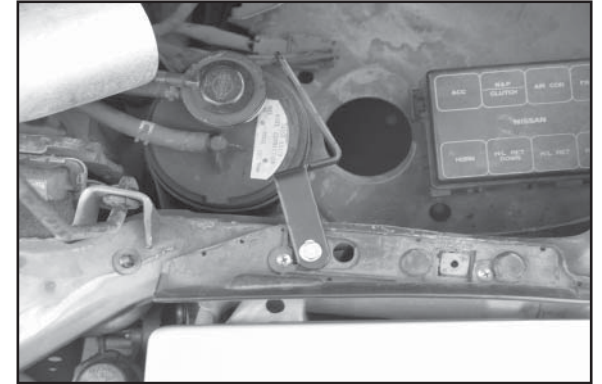

34. Install the spacer and bracket, then secure with provided hardware in the location where the bolt was removed in step #33.

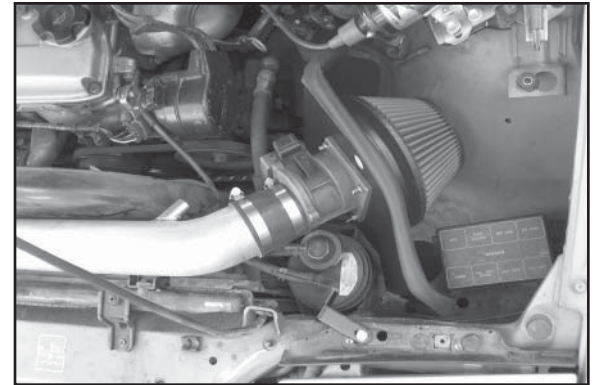

35. Install filter assembly into the vehicle.

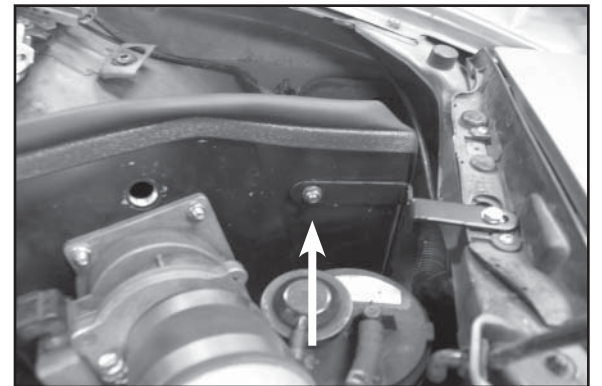

36. Attach upper bracket.

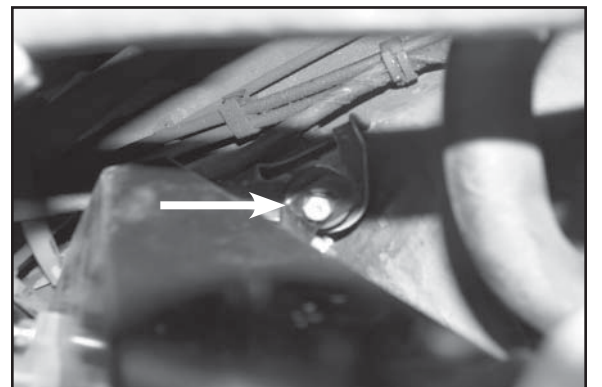

37. Attach lower bracket.

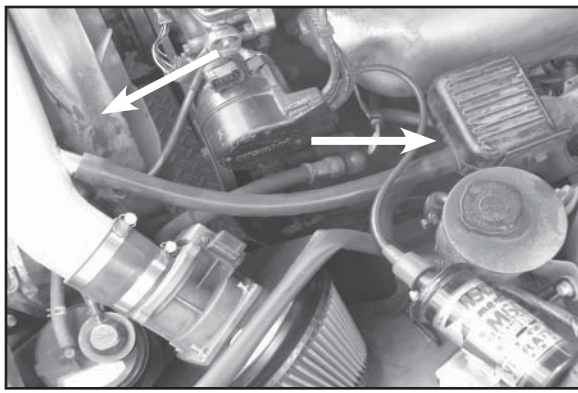

38. Install the 5/8" ID X 14 silicone hose from open vent in tube onto the K&N intake tube to the air bypass. Trim for best fit necessary.

39. Check for best fit, then secure all hardware and hose clamps.

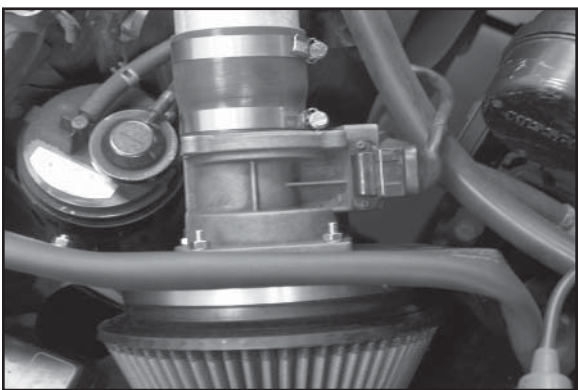

40. Reconnect the MAF sensor and reinstall the clip.

41. Reconnect the vehicle's negative battery cable. Double check to make sure everything is tight and properly positioned before starting the vehicle.

42. It will be necessary for all air filters to be checked periodically for realignment, clearance and tightening of all connections. Failure to follow the above instructions or proper maintenance may void warranty.

#### Road Test:

1. Start the engine with the transmission in neutral or park, and the parking brake engaged. Listen for air leaks or odd noises. For air leaks secure hoses and connections. For odd noises, find cause and repair before proceeding. This kit will function identically to the factory system except for being louder and much more responsive.

2. Test drive the vehicle. Listen for odd noises or rattles and fix as necessary.

3. If road test is fine, you can now enjoy the added power and performance from your kit.

4. K&N suggests checking the air filter element periodically for excessive dirt build-up. When the element becomes covered in dirt (or once a year), service it according to the instructions on the Recharger service kit, part number 99-5050 or 99-5000.