



# TYPHOON INTAKE SYSTEMS®

## INSTALLATION INSTRUCTIONS

### 69-8004 SUBARU 2008 WRX L4- 2.5L Turbo

**NOTE:** This kit was not designed to fit vehicles with a body lift.

#### TOOLS NEEDED:

Flat Blade Screwdriver  
Phillips Screwdriver  
3mm Allen Wrench  
10mm Allen Wrench  
Ratchet  
Extension  
10mm Socket

#### PARTS LIST:

| Description                        | Qty. | Part # | Description                        | Qty. | Part # | Description                   | Qty. | Part #  |
|------------------------------------|------|--------|------------------------------------|------|--------|-------------------------------|------|---------|
| A Hose Clamp #44                   | 2    | 08560  | F Bolt; M4 - 0.07 8MM, A/H CAP, SS | 2    | 07733  | K Edge Trim                   | 1    | 102486  |
| B Hose; Typhoon 2-3/4" x 2"L, Blk. | 1    | 08440  | G Gasket; 1/16" Neoprene           | 2    | 09202  | L Stud; 6MM-1.00 X 35MM L, SS | 4    | 08220   |
| C Intake Tube                      | 1    | 27440  | H Washer; 1/4"ID X 5/8"OD - SAE    | 2    | 08275  | M Adaptor; #350               | 1    | 21510   |
| D Nut; 6MM Nylock, Hex., SS        | 6    | 07512  | I Stud; 6-1.00 M/M, Rubber Mntd    | 2    | 07027  | N Hose clamp #80              | 1    | 08694   |
| E Washer; 6MM FLAT, SS             | 4    | 08269  | J Heat Shield                      | 1    | 07685  | O Air Filter                  | 1    | RP-5113 |

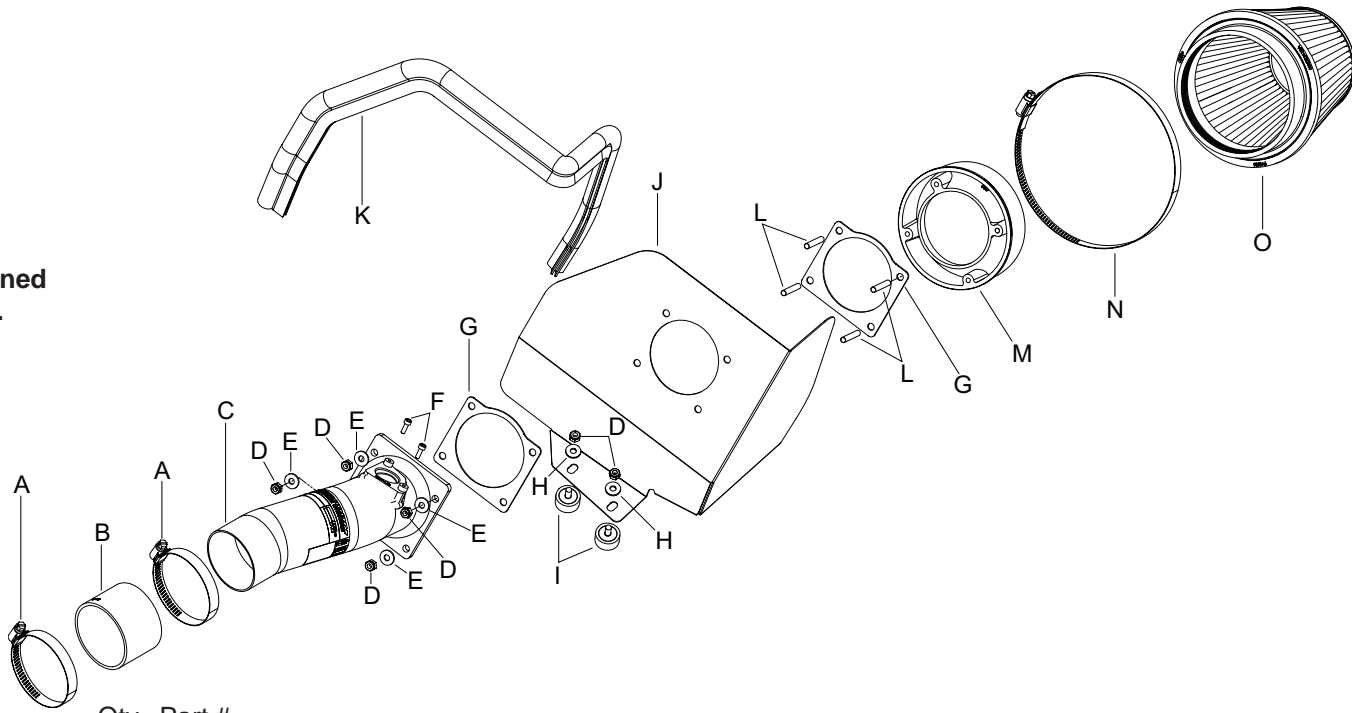

**WARNING:** The K&N Dry-Charger included with this kit must be installed on the K&N Air Filter when used with this K&N Typhoon Cold Air Intake System. The K&N Typhoon Intake System is a performance product that can be used safely during mild weather conditions. During harsh and inclement weather conditions, you must convert your Cold Air Intake System to a short ram configuration, or return your vehicle to the stock OEM air box and intake tract configuration. Failure to follow these instructions can void your warranty.

**NOTE: FAILURE TO FOLLOW INSTALLATION INSTRUCTIONS AND NOT USING THE PROVIDED HARDWARE MAY DAMAGE THE INTAKE TUBE, THROTTLE BODY AND ENGINE.**

#### TO START:

1. Turn off the ignition and disconnect the negative battery cable.

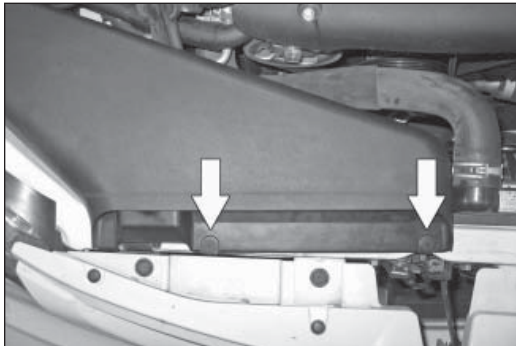

2. Remove the two fasteners which retain the fresh air inlet scoop and then remove the fresh air inlet scoop from the vehicle as shown.

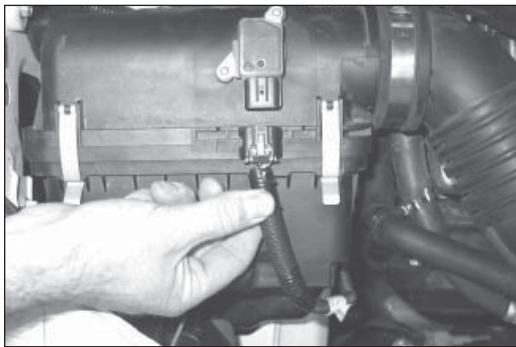

3. Disconnect the mass air sensor electrical connection and then unhook the wiring harness from the air box.

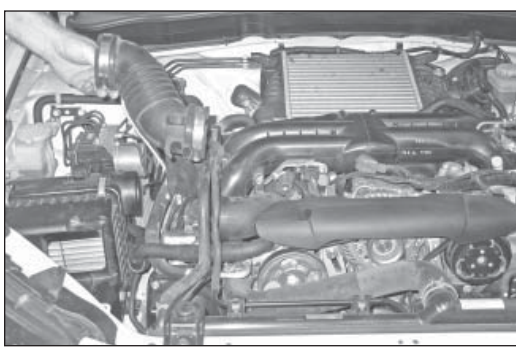

4. Loosen the two hose clamps which secure the factory intake tube and then remove the intake tube from the vehicle.

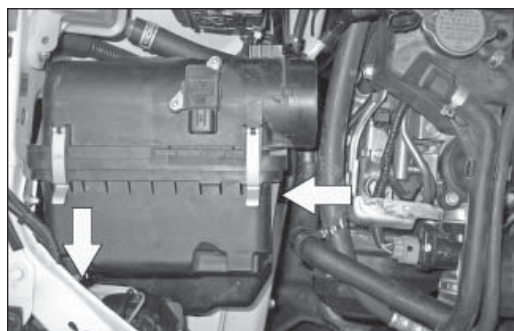

5. Loosen and remove the two bolts which secure the air box to the inner fender.

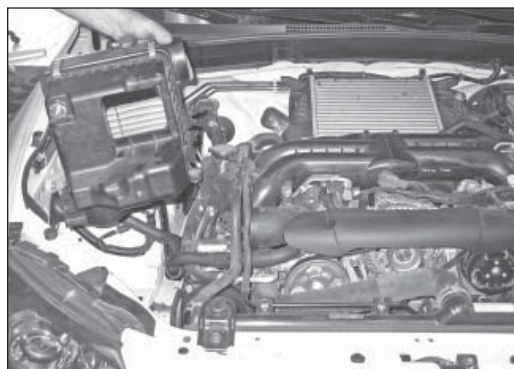

6. Remove the air box assembly from the vehicle.

**NOTE: K&N recommends that customers do not discard factory air intake.**

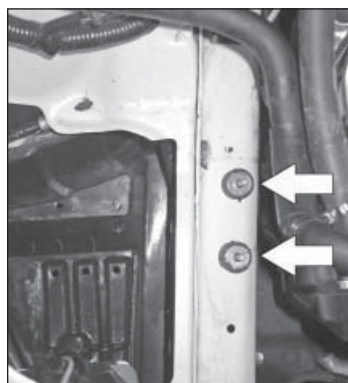

7. Install the two rubber mounted studs into the inner fender as shown.

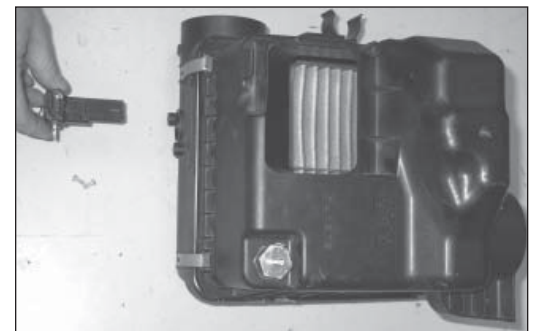

8. Remove the two screws which secure the mass air sensor and then remove the mass air sensor from the air box as shown.

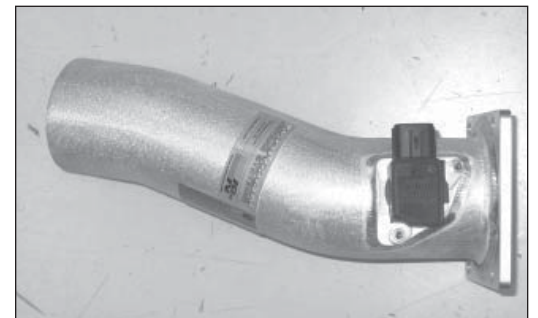

9. Install the mass air sensor into the K&N Intake Tube and secure with the provided hardware.

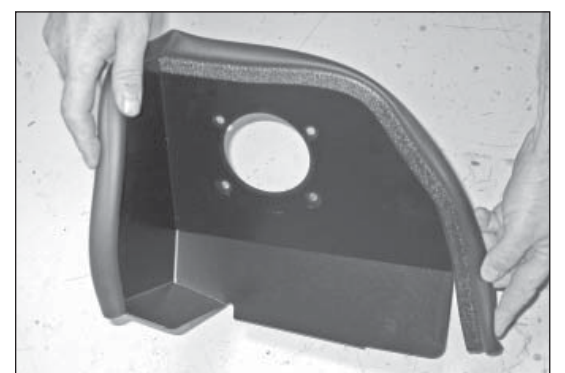

10. Install the provided edge trim onto the heat shield as shown.  
**NOTE: Some trimming of the edge trim will be necessary.**

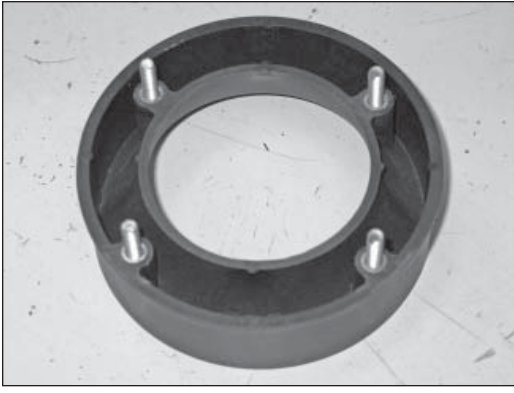

11. Install the four 6mm studs into the filter adapter as shown.

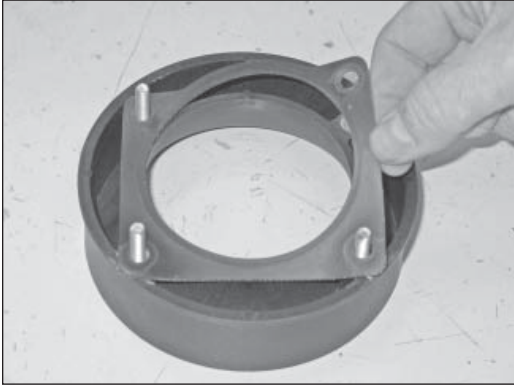

12. Install the filter adapter gasket onto the four studs as shown.



13. Install the filter adapter assembly into the heat shield and then install the remaining gasket onto the studs protruding through the heat shield as shown.

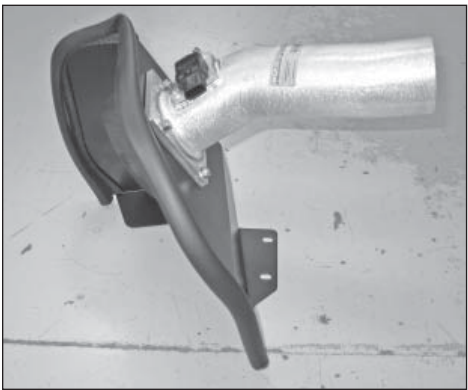

14. Install the K&N Intake Tube onto the studs and secure with the provided nuts and washers.



15. Install the K&N Air Filter onto intake assembly and secure with the provided hose clamp.

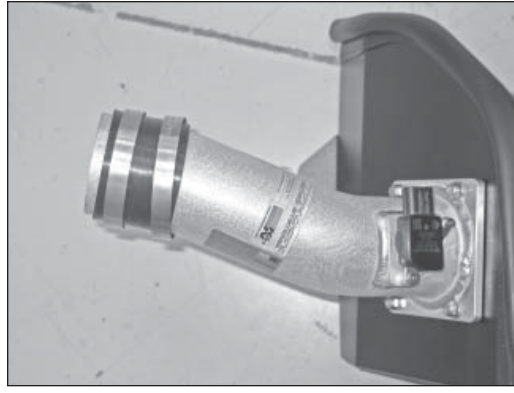

16. Install the provided silicone hose (08440) onto the intake tube as shown. **NOTE: Slide the hose all the way onto the tube to expose the end of the tube so to ease kit installation.**

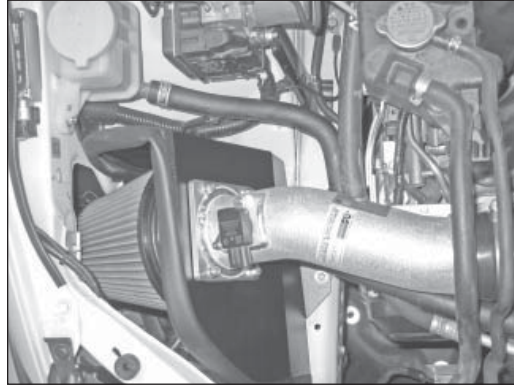

17. Install the K&N intake kit so that the heat shield rests on the rubber mounted studs installed during step #7. Secure the heat shield with the provided hardware. Slide the silicone hose onto the turbo inlet and secure with the provided hose clamp.

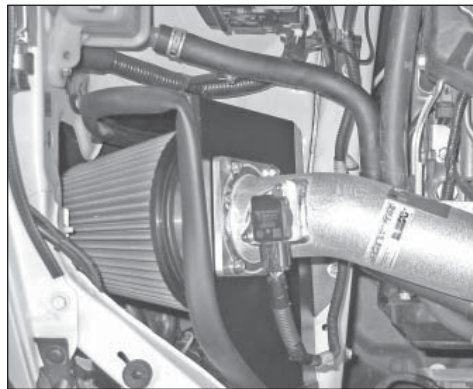

18. Reconnect the mass air sensor electrical connection as shown.

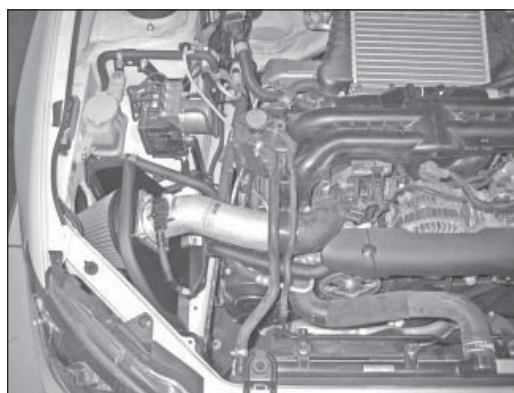

18. Reconnect the mass air sensor electrical connection as shown.

19. Reconnect the vehicle's negative battery cable. Double check to make sure everything is tight and properly positioned before starting the vehicle.

20. The C.A.R.B. exemption sticker, (attached), must be visible under the hood, so the emissions inspector can see it when the vehicle is required to be tested for emissions. California requires testing every two years, other states may vary.

21. It will be necessary for all Typhoons to be checked periodically for realignment, clearance and tightening of all connections. Failure to follow the above instructions or proper maintenance may void warranty.

#### Road Testing

1. Start the engine with the transmission in neutral or park, and the parking brake engaged. Listen for air leaks or odd noises. For air leaks secure hoses and connections. For odd noises, find cause and repair before proceeding. This kit will function identically to the factory system except for being louder and much more responsive.

2. Test drive the vehicle. Listen for odd noises or rattles and fix as necessary.

3. If road test is fine, you can now enjoy the added power and performance from your kit.

4. K&N suggests checking the air filter element periodically for excessive dirt build-up. When the element becomes covered in dirt (or once a year), service it according to the instructions on the Re-charger service kit, part number 99-5050 or 99-5000.