

INSTALLATION INSTRUCTIONS

77-1516 DODGE 2000-04 Dakota 2000-03 Durango V8-4.7L

NOTE: This kit was not designed to fit vehicles with a body lift.

TOOLS NEEDED:

Flat Blade Screwdriver
10mm Socket
13mm Socket
Long Extension
Ratchet
7/16" Open end wrench
7/16" Socket
Drill
3/4" Drill Bit

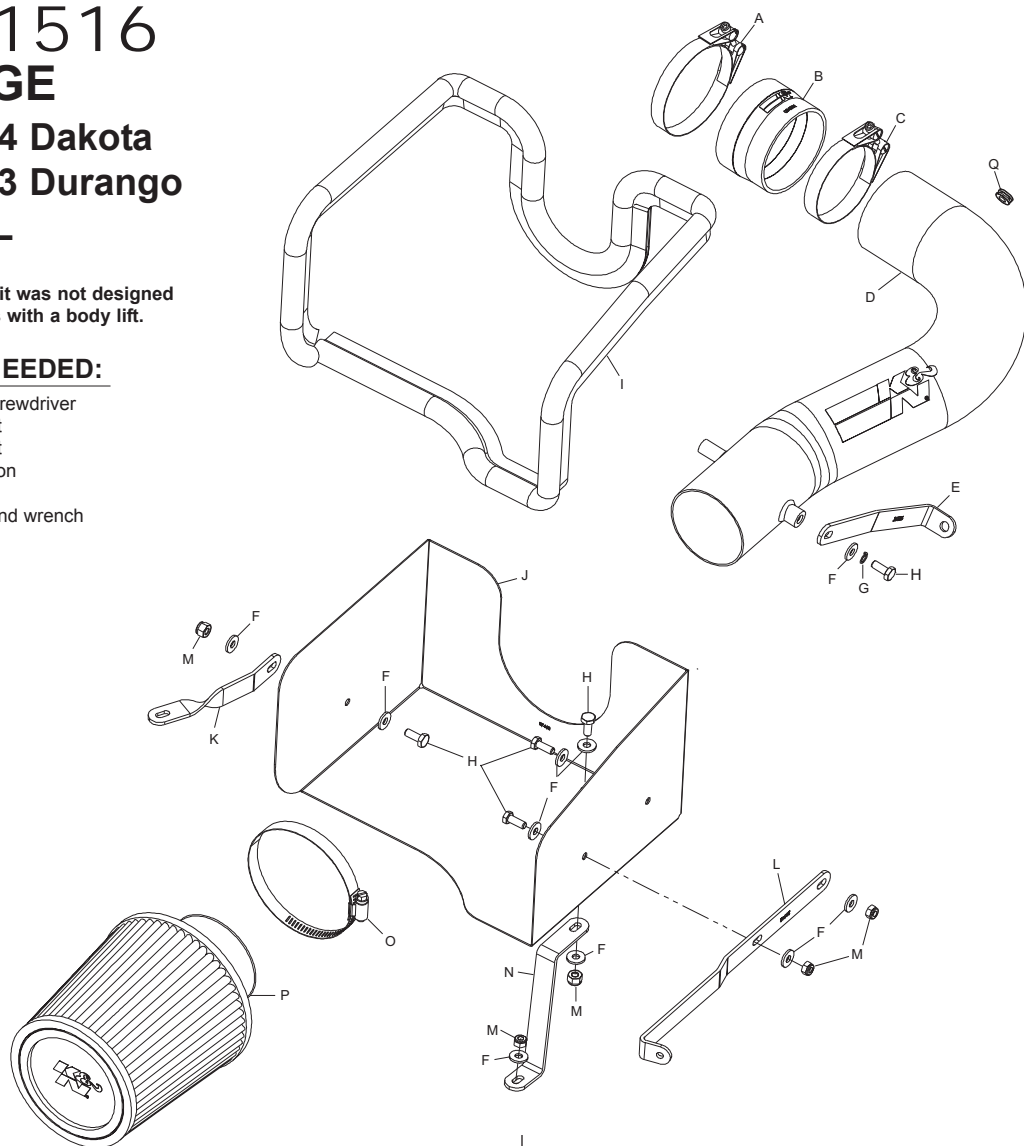

PARTS LIST:

Desc.	Qty.	Part#
A hose clamp #48	1	08601
B silicone hose	1	084031
C hose clamp #48	1	08601
D intake tube	1	27356KP
E bracket; sm. "L"	1	26526
F washer; 1/4" id x 5/8" od. Flat	10	08275
G washer; 1/4" split lock	1	08198
H bolt; 6mm-1.00 x 16mm, hex	5	07703
I edge trim 57"	1	102470
J heat shield	1	07462
K bracket; twist	1	26544
L bracket; large "L"	1	26542
M nut; 6mm nylock	5	07553
N bracket; "Z"	1	26543
O hose clamp # 48	1	08610
P filter charger	1	RU-4990
Q grommet	1	08167

TO START:

1. Turn the ignition OFF and disconnect the vehicle's negative battery cable.



2. Loosen hose clamp at the throttle body and air intake tube as shown.



3. Loosen and remove the two bolts that retain the air resonator to intake manifold as shown.



3a. On vehicles that come equipped with an air temp sensor, disconnect the electrical connection as shown.



3b. To remove temp sensor from resonator, turn sensor 1/8 of a turn counter clockwise and remove sensor as shown.



4. Remove the air resonator from vehicle as shown.



5. Remove vent hose from airbox as shown.



6. Loosen and remove nut that retains airbox to vehicle.



7. Pull firmly upwards on stock airbox to remove from vehicle as shown.



8. Unscrew plastic airbox retaining stud from vehicle as shown.



9. Apply the provided trim seal to the heat shield as shown. Trim if necessary.



10. Mount the provided "Z" bracket onto the inner fender well as shown. Do not tighten completely.



11. Install the provided large "L" bracket onto the heat shield as shown. Do not tighten completely.



12. Install the provided twist bracket onto heat shield as shown. Do not tighten completely.

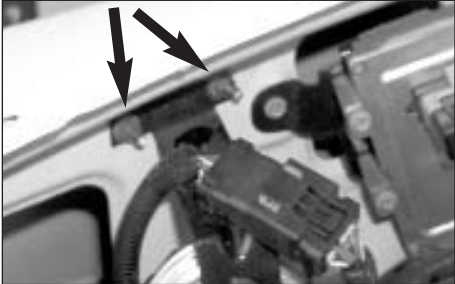

13. Remove the nuts that retains the cruise control bracket to inner fender.



14. Install the heat shield into the vehicle as shown.



15. Using the nuts that was removed in step 13, secure the bracket to the inner fender well.



16. Using the nut that was removed in step 6, secure the bracket to the airbox mounting stud as shown. Do not tighten at completely at this time .

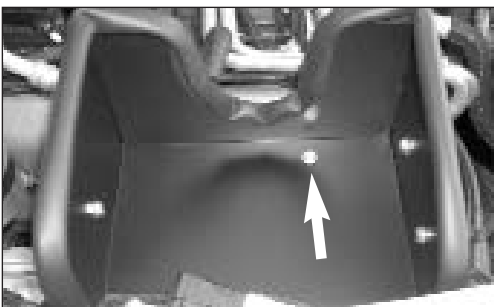

17. Attach the heat shield onto the lower "Z" bracket with hardware provided.



18. Remove the bolt from the A/C compressor as shown.



19. Install the tube-mounting bracket onto the A/C compressor with the bolt removed in step #18.



20. Install the silicone hose onto the K&N intake tube as shown.

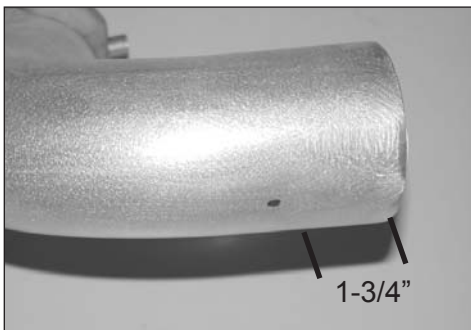

20a. On models that come equipped with an external temp sensor, mark the intake tube 1-3/4" from end of tube, then drill a 3/4" hole into intake tube

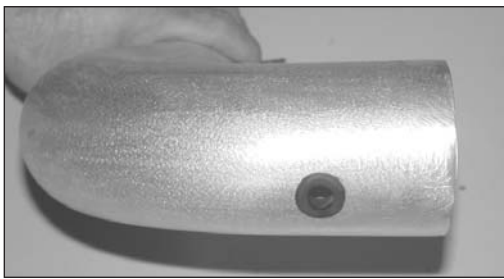

20b. Install the provided grommet into the intake tube as shown.

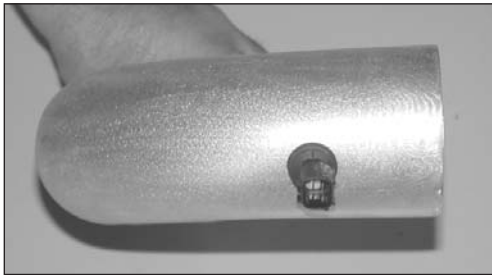

20c. Remove the factory O-ring from the temp sensor then install the sensor into the intake tube as shown.



21. Install the K&N intake tube onto the throttle body and secure with the provided hose clamp, then secure to the tube mounting bracket installed in step #19 with the provided hardware as shown.



22. Remove the vent hose from vehicle as shown.



23. Cut the vent hose that was removed in step 22 as shown.



24. Reinstall the vent hose onto the crank case vent tube and then connect the other end to the K&N intake tube as shown.

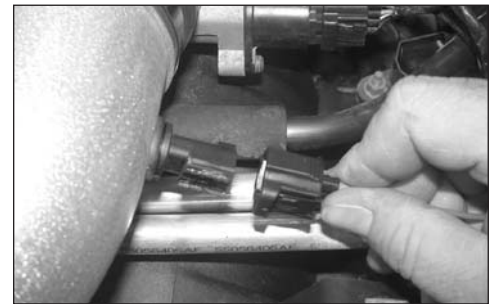

25. On vehicle that came equipped with an air temp sensor, re-connect the electrical connection as shown.



26. Install the K&N Filtercharger onto K&N intake tube as shown, then tighten completely.



27. Reconnect the negative battery cable and double check to make sure everything is tightened and properly positioned before starting the vehicle.

28. The C.A.R.B. exemption sticker, (attached), must be visible under the hood so that an emissions inspector can see it when the vehicle is required to be tested for emissions. California requires testing every two years, other states may vary.

29. It will be necessary for all intakes to be checked periodically for realignment, clearance and tightening of all connections. Failure to follow the above instructions or proper maintenance may void warranty.

ROAD TESTING:

1. Start the engine with the transmission in neutral or park, and the parking brake engaged. Listen for air leaks or odd noises. For air leaks secure hoses and connections. For odd noises, find cause and repair before proceeding. This kit will function identically to the factory system except for being louder and much more responsive.

2. Test drive the vehicle. Listen for odd noises or rattles and fix as necessary.

3. If road test is fine, you can now enjoy the added power and performance from your kit.

4. K&N suggests checking the Filtercharger element periodically for excessive dirt build-up. When the element becomes covered in dirt (or once a year), service it according to the instructions on the Recharger service kit, part number 99-5050 or 99-5000.