

INSTALLATION INSTRUCTIONS

77-1539 DODGE / CHRYSLER

2004-06 DURANGO
2007 ASPEN
V8-5.7L HEMI

NOTE: This kit was not designed to fit vehicles with a body lift.

TOOLS NEEDED:

Flat blade screwdriver
Ratchet
Extension
10mm socket
13mm socket
15mm socket
17mm socket
10mm End wrench
13mm End wrench
15mm End wrench

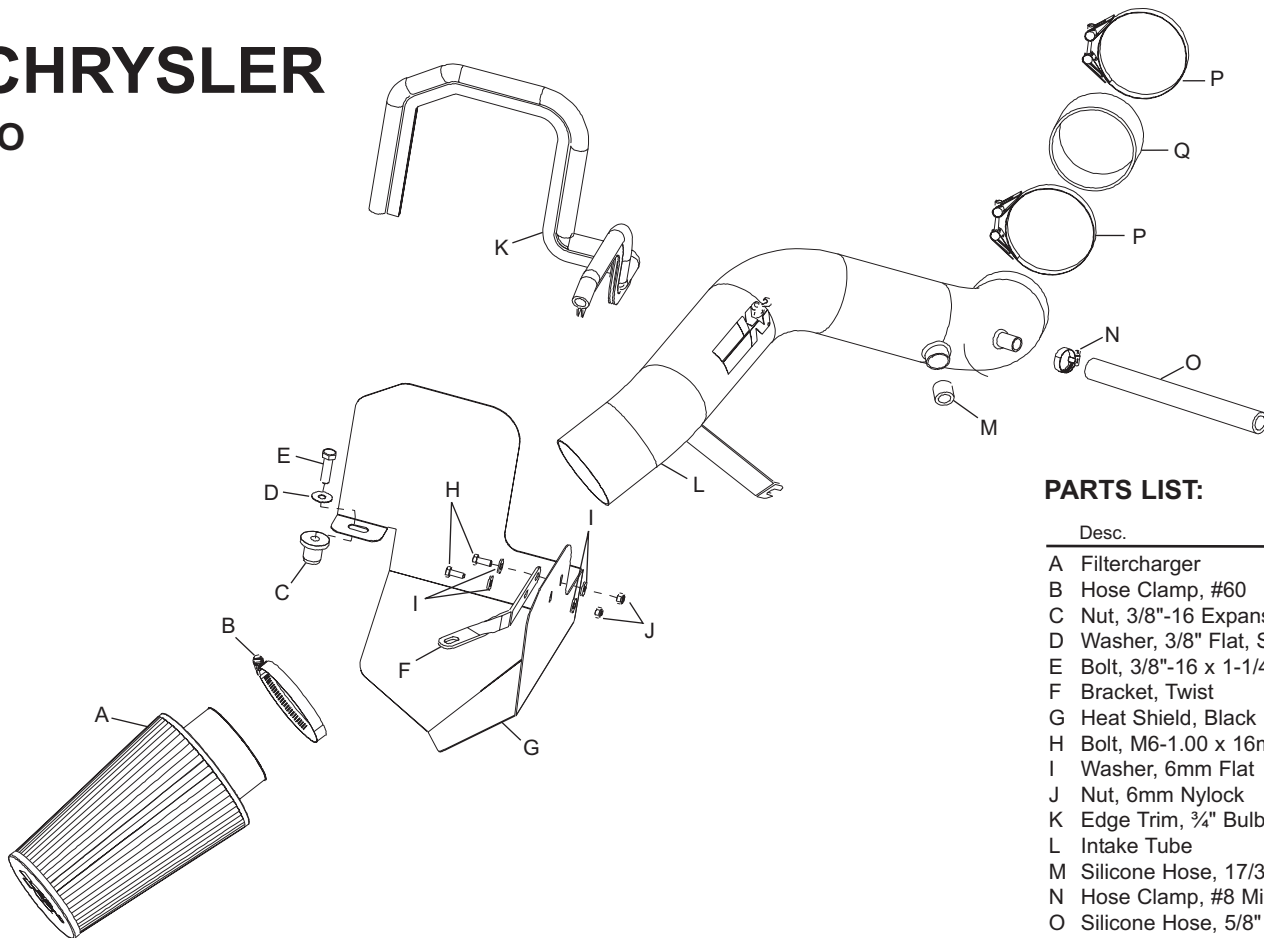

PARTS LIST:

Desc.	QTY.	Part #
A Filtercharger	1	RC-3690
B Hose Clamp, #60	1	08624
C Nut, 3/8"-16 Expansion	1	08163
D Washer, 3/8" Flat, SS	1	08134
E Bolt, 3/8"-16 x 1-1/4"L, Hex	1	07779
F Bracket, Twist	1	07197
G Heat Shield, Black	1	074023
H Bolt, M6-1.00 x 16mm L, Hex	2	07812
I Washer, 6mm Flat	4	08269
J Nut, 6mm Nylock	2	07512
K Edge Trim, 3/4" Bulb, 30"L	1	102489
L Intake Tube	1	27421
M Silicone Hose, 17/32 x 11/16"L	1	084054
N Hose Clamp, #8 Mini	1	08410
O Silicone Hose, 5/8" X 13"L	1	08602
P Hose Clamp, #56	2	08620
Q Silicone Hose, 3-1/2"ID	1	084052

NOTE: FAILURE TO FOLLOW INSTALLATION INSTRUCTIONS AND NOT USING THE PROVIDED HARDWARE MAY DAMAGE THE INTAKE TUBE, THROTTLE BODY AND ENGINE.

TO START:

1. Turn the ignition OFF and disconnect the vehicle's negative battery cable.



2. Disconnect the crank case vent hose at the oil filler stand off as shown.



3. Loosen the intake tube hose clamps and remove the intake tube assembly from the vehicle.

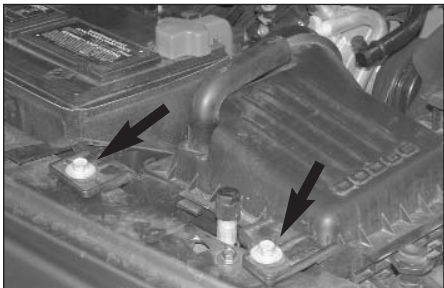

4. Remove the two airbox retaining bolts.



5. Pull up firmly to dislodge the air box from the mounting grommet, and remove the air box from the vehicle.

NOTE: K&N recommends that you do not discard your factory air intake.



6. Unclip the engine wire harness clip from the resonator box as shown.



7. Depress the locking tab on the air temp sensor and disconnect its electrical connection.



8. Remove the two 10mm resonator retaining bolts, then remove the resonator from the vehicle.



9. Remove the resonator silicone gasket from the throttle body.

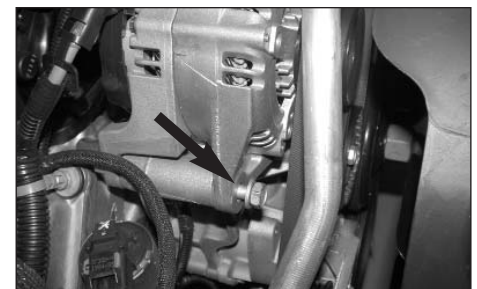

10. Loosen the bolt on the alternator but do not remove as shown.



11. Install the heat shield bracket (07197) onto the heat shield with the provided hardware.

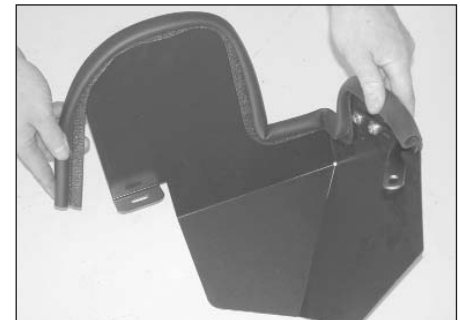

12. Install the provided edge trim onto the heat shield. Trim if necessary.



13. Remove the core support mounting bolt shown with a 13mm wrench, and pull out the stock air box mounting grommet shown.



14. Install the 3/8" threaded insert provided into the air box mounting grommet hole vacated in step #13.



15. Install the K&N heat shield assembly and secure the mounting bracket to the radiator core support with original bolt removed in step #13. Secure the rear of the heat shield to the 3/8" threaded insert with the provided hardware.



16. Install the silicone hose (08698) onto the throttle body and secure with the provided hose clamp.



17. Twist the temp sensor counter clockwise to unlock and remove the temp sensor from the resonator.



18. Remove the O-ring from the air temp sensor as shown.

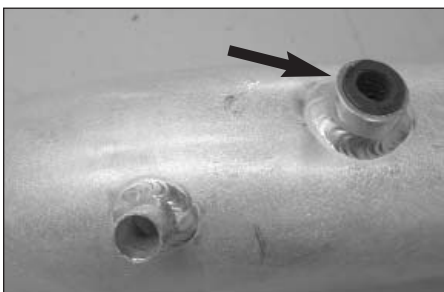

19. Install the silicone hose into the fitting on the K&N Intake Tube as shown.



20. Install the air temperature sensor into the Silicone hose on the K&N intake tube as shown.

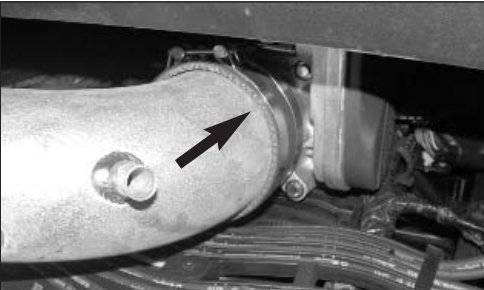

21. Slide the K&N Intake tube into the silicone hose on the throttle body as shown.

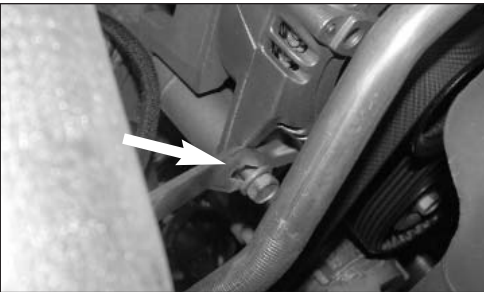

22. Rotate the bracket onto the hex bolt from step 10 and snug the bolt, but do not completely tighten at this time.



23. Remove the stock crank case vent hose as shown.



24. Connect the provided silicone hose to the crank case vent on the oil fill tube, then, connect the other end to the vent on the K&N intake tube as shown.

NOTE: Cut 1 inch off the provided silicone hose.



25. Reconnect the air temperature sensor electrical connection as shown.

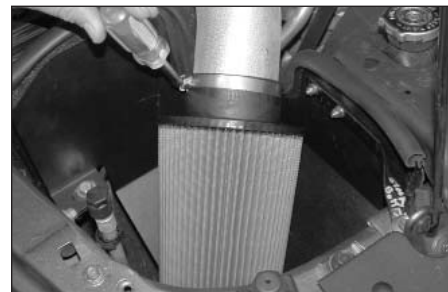

26. Install the K&N Filtercharger and secure with the provided hose clamp as shown.



27. Reconnect the negative battery cable and double check to make sure everything is tightened and properly positioned before starting the vehicle.

28. The C.A.R.B. exemption sticker, (attached), must be visible under the hood so that an emissions inspector can see it when the vehicle is required to be tested for emissions. California requires testing every two years, other states may vary.

29. It will be necessary for all Performance Intake Kit's to be checked periodically for realignment, clearance and tightening of all connections. Failure to follow the above instructions or proper maintenance may void warranty.

ROAD TESTING:

1. Start the engine with the transmission in neutral or park, and the parking brake engaged. Listen for air leaks or odd noises. For air leaks secure hoses and connections. For odd noises, find cause and repair before proceeding. This kit will function identically to the factory system except for being louder and much more responsive.

2. Test drive the vehicle. Listen for odd noises or rattles and fix as necessary.

3. If road test is fine, you can now enjoy the added power and performance from your kit.

4. K&N suggests checking the Filtercharger element periodically for excessive dirt build-up. When the element becomes covered in dirt (or once a year), service it according to the instructions on the Recharger service kit, part number 99-5050 or 99-5000.