



INSTALLATION INSTRUCTIONS

77-2577

FORD

2007-10 F250, F350

V8-5.4L

NOTE: This kit was not designed to fit vehicles with a body lift.

TOOLS NEEDED:

- Ratchet
- Extension
- 13mm Socket
- 10mm Socket
- Flat Blade Screwdriver
- T25 Torx
- 3mm Allen Wrench

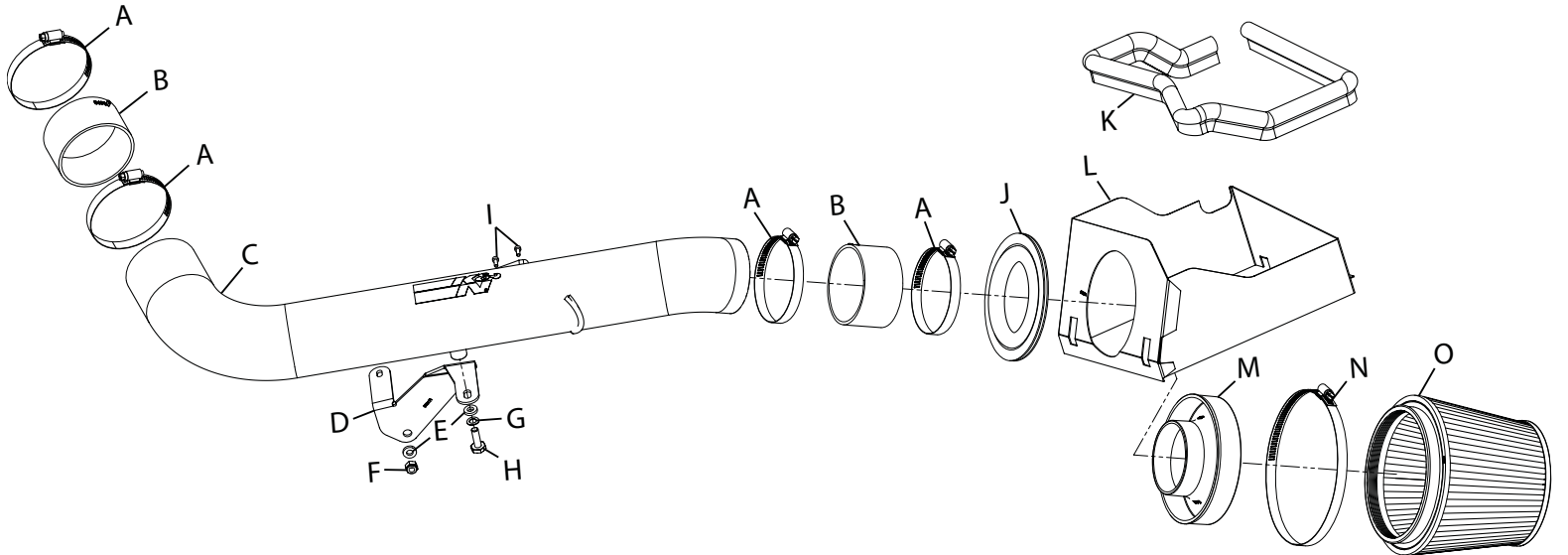

PARTS LIST:

Description	Qty.	Part #	Description	Qty.	Part #	Description	Qty.	Part #
A Hose Clamp #56	4	08620	F Nut; 8MM Nylock, SS	1	07502	K Edge Trim (39")	1	102496
B Hose; 3-1/2" ID X 2" L	2	08698	G Washer; 8MM Spring(Wave)	1	08239	L Heat Shield	1	07355-1
C Intake Tube	1	27453	H Bolt; M8 - 1.0 X 20MM, Tap	1	06533	M Adaptor; #380	1	21512
D Bracket; "Z", STL, FB/PC	1	083111	I Bolt; M4 - 0.07 8MM, A/H Cap, SS	2	07733	N Hose Clamp # 104	1	08697
E Washer; 5/16"ID X 5/8"OD,	2	08276	J Edge Trim (17")	1	102469	O Air Filter	1	RC-5173

NOTE: FAILURE TO FOLLOW INSTALLATION INSTRUCTIONS AND NOT USING THE PROVIDED HARDWARE MAY DAMAGE THE INTAKE TUBE, THROTTLE BODY AND ENGINE.

TO START:

1. Turn off the ignition and disconnect the negative battery cable.



2. Release the red locking clip and then disconnect the mass air sensor electrical connection, and then unhook the wiring harness from the power steering reservoir.



3. Loosen the hose clamps which secure the stock intake tube the air filter housing and to the intake plenum.



4. Remove the stock intake tube from the vehicle.



5. Release the three clips which secure the airbox lid.



6. Remove the airbox lid and stock air filter.
NOTE: K&N Engineering, Inc., recommends that customers do not discard factory air intake.

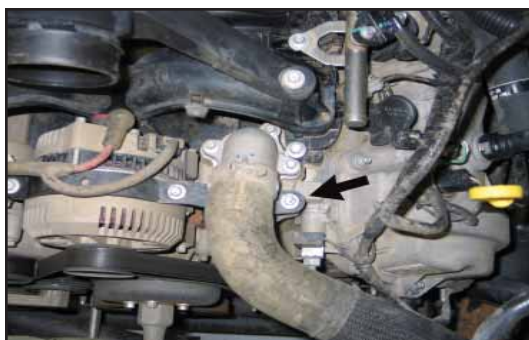

7. Remove the upper alternator mounting bracket shown.
NOTE: This bolt will be reused in the next step.

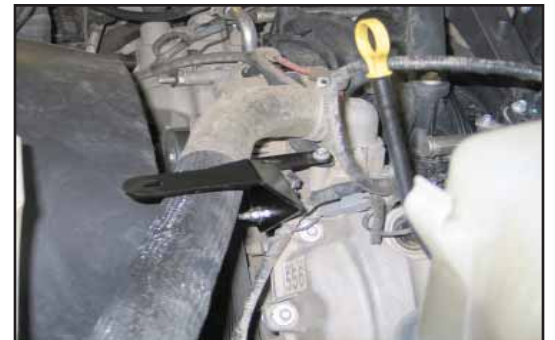

8. Install the tube mounting bracket (083111) and secure with the bolt removed from the previous step and the provided hardware.

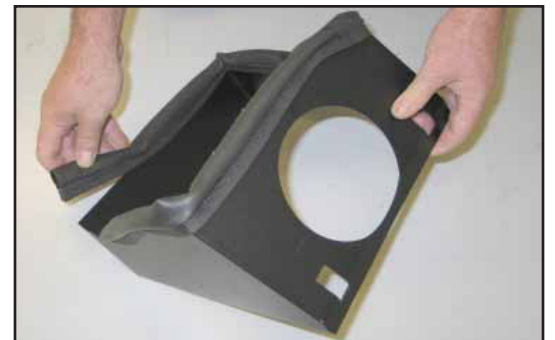

9. Install the provided long edge trim onto the heat shield as shown.
NOTE: Some trimming of the edge trim will be necessary.



10. Install the provided edge trim into the hole in the heat shield as shown.
NOTE: Some trimming of the edge trim will be necessary.



11. Remove the center airbox lid mounting clip from the lower airbox as shown.



12. Install the heat shield assembly onto the lower airbox and clip into place with the upper airbox mounting clips.

NOTE: A gap is normal between the lower airbox and heat shield on the clip side of the heat shield.



13. Install the provided silicone hose (08698) onto the intake plenum and secure with the provided hose clamp.



14. Install the filter adapter into the K&N® air filter and secure with the provided hose clamp.



15. Install the silicone hose (08698) onto the filter adapter and secure with the provided hose clamp.



16. Place the filter assembly into the lower airbox housing as shown.



17. Remove the two screws securing the mass air sensor to the upper airbox and then remove the mass air sensor from the upper airbox.



18. Install the mass air sensor into the K&N® intake tube and secure with the provided mounting screws.



19. Place the K&N® intake tube through the heat shield, install the air filter assembly onto the end of the tube then install the intake tube into the silicone hose on the intake plenum. Secure the intake tube with the hardware and hose clamps provided.

NOTE: Be sure to secure the air filter assembly with the provided hose clamp.



20. Connect the mass air sensor electrical connection.



21. Reconnect the vehicle's negative battery cable. Double check to make sure everything is tight and properly positioned before starting the vehicle.

22. It will be necessary for all K&N® high flow intake systems to be checked periodically for re-alignment, clearance and tightening of all connections. Failure to follow the above instructions or proper maintenance may void warranty.

ROAD TESTING:

1. Start the engine with the transmission in neutral or park, and the parking brake engaged. Listen for air leaks or odd noises. For air leaks secure hoses and connections. For odd noises, find cause and repair before proceeding. This kit will function identically to the factory system except for being louder and much more responsive.

2. Test drive the vehicle. Listen for odd noises or rattles and fix as necessary.

3. If road test is fine, you can now enjoy the added power and performance from your kit.

4. K&N Engineering, Inc., suggests checking the air filter element periodically for excessive dirt build-up. When the element becomes covered in dirt (or once a year), service it according to the instructions on the Recharger® service kit, part number 99-5050 or 99-5000.

STREET LEGAL IN MOST STATES

NOT LEGAL FOR USE IN CA & OTHER STATES ADOPTING CA EMISSIONS STANDARDS

See our catalog or knfilters.com for CARB status on each part for a specific vehicle

* FREE K&N® decal To register your warranty, please see us online at knfilters.com/register. FREE K&N® decal *

• 1455 CITRUS ST., P.O. BOX 1329, RIVERSIDE, CA., U.S.A. 92502 • TECH SERVICE 800-858-3333 • FAX 951-826-4001
• e-mail: tech@knfilters.com • WWW: <http://www.knfilters.com>