

## INSTALLATION INSTRUCTIONS

### 77-3037 HUMMER

2003-07 H2  
V8-6.0L

NOTE: This kit was not designed to fit vehicles with a body lift.

#### TOOLS NEEDED:

Ratchet  
Extension  
8MM Socket  
10mm Socket  
10mm Wrench  
7/16" Wrench  
9/64" Allen Wrench  
Flat Blade Screwdriver

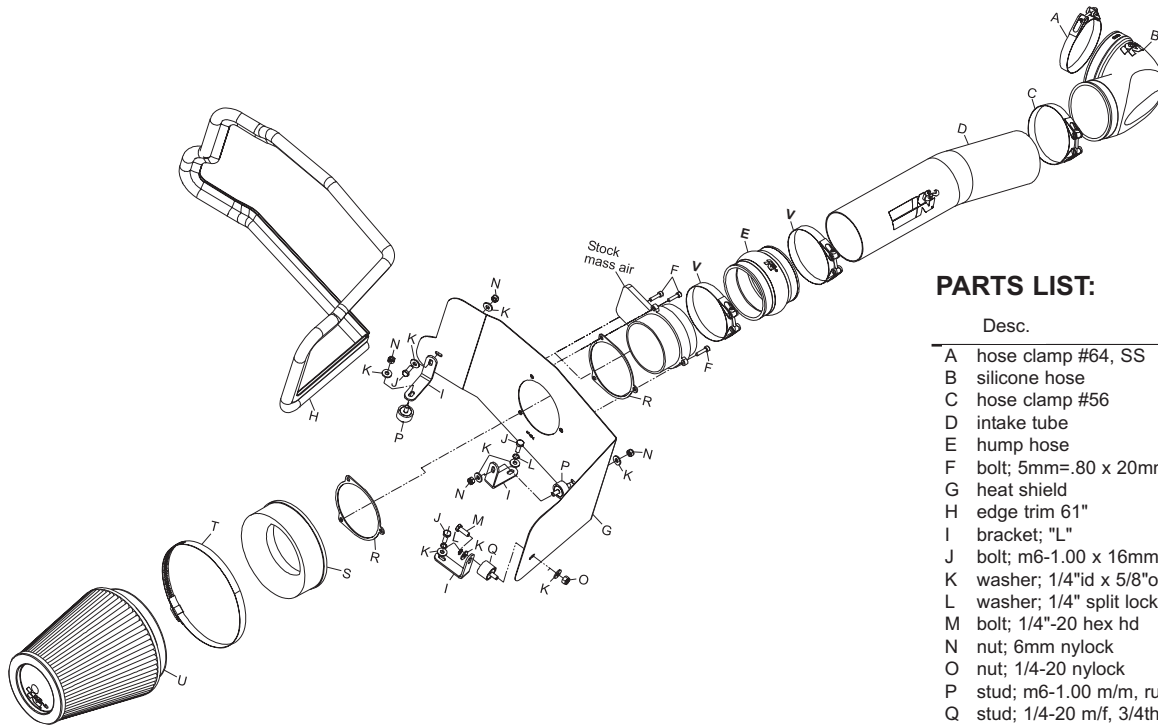

#### PARTS LIST:

Desc.	Qty.	Part#
A hose clamp #64, SS	1	08645
B silicone hose	1	084053
C hose clamp #56	1	08620
D intake tube	1	27178
E hump hose	1	084057
F bolt; 5mm=.80 x 20mm, allen	3	08320
G heat shield	1	074016
H edge trim 61"	1	102492
I bracket; "L"	3	070662
J bolt; m6-1.00 x 16mm hex hd	3	07703
K washer; 1/4" id x 5/8" od, flat	9	08275
L washer; 1/4" split lock	3	08198
M bolt; 1/4"-20 hex hd	1	08386
N nut; 6mm nylock	4	07553
O nut; 1/4"-20 nylock	1	07517
P stud; m6-1.00 m/m, rubber mounted	2	07027
Q stud; 1/4"-20 m/f, 3/4" thk, rubber mntd	1	070226
R gasket; 1/16" neoprene	2	09033
S filter adapter #240	1	08783
T hose clamp #104	1	08697
U air filter	1	RF-1041
V hose clamp #52	2	08610

NOTE: FAILURE TO FOLLOW INSTALLATION INSTRUCTIONS AND NOT USING THE PROVIDED HARDWARE MAY DAMAGE THE INTAKE TUBE, THROTTLE BODY AND ENGINE.

#### TO START:

1. Turn the ignition OFF and disconnect the vehicle's negative battery cable.



2. Remove the 8mm bolt that retains the engine cover onto the engine then remove the cover from vehicle.



3. Disconnect the mass air sensor electrical connection.



4. Loosen the hose clamp at the throttle body.

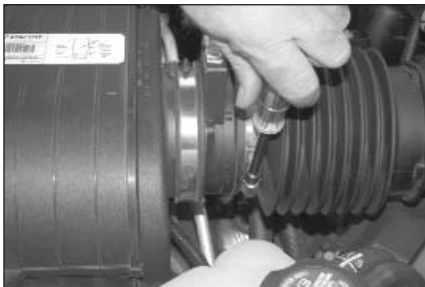

5. Loosen the hose clamp at the mass air sensor.



6. Detach the intake tube from the throttle body and mass air sensor then remove the intake assembly. NOTE: K&N recommends that customers do not discard factory air intake.

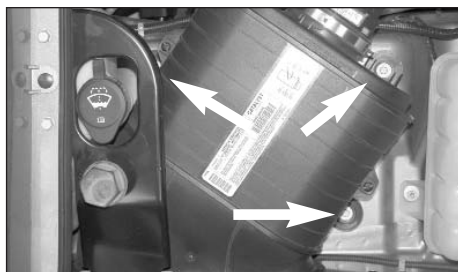

7. Remove the 3 10mm bolts that retain the air box onto the vehicle.



8. Remove the air box from vehicle as shown.



9. Loosen the hose clamp that retains the mass air sensor onto the air box then remove the mass air sensor from the air box.



10. Install the mass air sensor and filter adapter onto the heat shield using the gaskets and hardware provided.

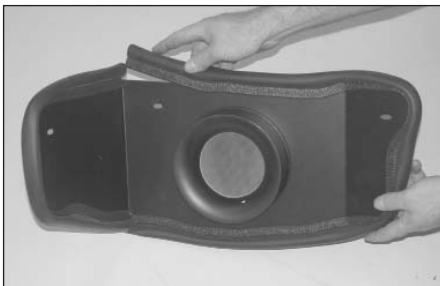

11. Install the edge trim onto the heat shield. Trim if needed.

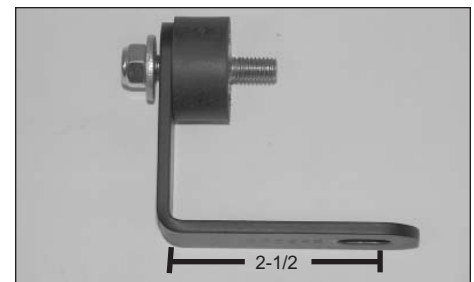

12. Install the 1/2 long rubber mounted stud onto bracket as shown.

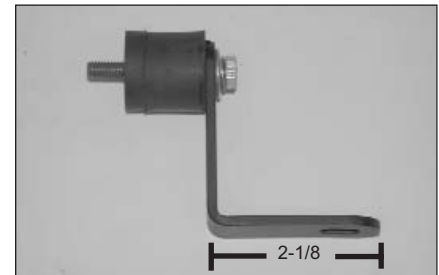

13. Install the 1" long rubber mounted stud onto bracket as shown.



14. Install the rubber mounted stud onto the vehicle as shown.



15. Install the 3 brackets onto the vehicle with the provided hardware as shown. Don't tighten completely at this time.



16. Install the silicone hose (084053) onto the K&N intake tube as shown using the supplied hose clamps.

NOTE: The synch bolt in the #400 hose clamp at the throttle body will need to be replaced with the longer synch bolt supplied.



17. Install the heat shield assembly into vehicle as shown.



18. Secure the brackets to the heat shield with the provided hardware. Do not tighten completely.



19. Install the silicone hose (084053) onto the K&N intakes tube as shown using the supplied hose clamps.

**NOTE: Do not completely tighten the hose clamp at this time.**

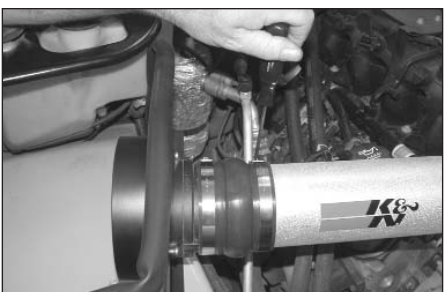

20. Install the K&N intake tube assembly onto the throttle body and into the silicone hose at the mass air sensor, then tighten the hose clamp to secure at the mass air sensor.

**NOTE: The synch bolt in the #400 hose clamp at the throttle body will need to be replaced with the longer synch bolt supplied.**



21. Tighten the hose clamp, which secures the silicone hose to the throttle body.



22. Install the air filter onto the mass air sensor and then tighten hose clamp.



23. Reconnect the mass air electrical connection as shown.



24. Re-install the engine cover removed in step #2 and reconnect the negative battery cable and double check to make sure everything is tightened and properly positioned before starting the vehicle.

25. The C.A.R.B. exemption sticker, (attached), must be visible under the hood so that an emissions inspector can see it when the vehicle is required to be tested for emissions. California requires testing every two years, other states may vary.

26. It will be necessary for all intakes to be checked periodically for realignment, clearance and tightening of all connections. Failure to follow the above instructions or proper maintenance may void warranty.

#### ROAD TESTING:

1. Start the engine with the transmission in neutral or park, and the parking brake engaged. Listen for air leaks or odd noises. For air leaks secure hoses and connections. For odd noises, find cause and repair before proceeding. This kit will function identically to the factory system except for being louder and much more responsive.

2. Test drive the vehicle. Listen for odd noises or rattles and fix as necessary.

3. If road test is fine, you can now enjoy the added power and performance from your kit.

4. K&N suggests checking the Air filter element periodically for excessive dirt build-up. When the element becomes covered in dirt (or once a year), service it according to the instructions on the Recharger service kit, part number 99-5050 or 99-5000.