



INSTALLATION INSTRUCTIONS



2013-2014 BMW 535i 3.0L

PART NO. 15289

BILL OF MATERIALS:

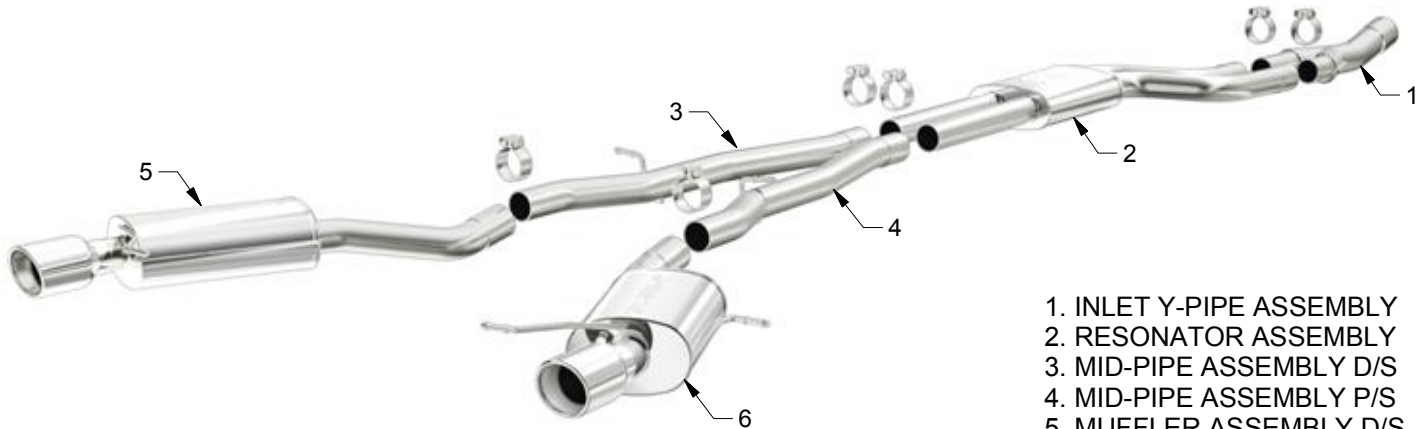

1. INLET Y-PIPE ASSEMBLY
2. RESONATOR ASSEMBLY
3. MID-PIPE ASSEMBLY D/S
4. MID-PIPE ASSEMBLY P/S
5. MUFFLER ASSEMBLY D/S
6. MUFFLER ASSEMBLY P/S



WEAR SAFETY GLASSES



READ INSTRUCTIONS THOROUGHLY BEFORE INSTALLING PRODUCT

SHOP SUPPLIES:



SPRAY LUBRICANT

To ease removal of existing exhaust components (especially on older vehicles) spray penetrating lubricant on all fasteners and hangers/insulators that will be loosened or removed and let soak before disassembly.

HARDWARE KIT:

- 1.[6] 2.50" Clamp

MINIMUM REQUIRED TOOLS:



15mm, 13mm, 12mm



Hanger Tool (Or Pry Bar)

MAGNAFLOW RECOMMENDS PROFESSIONAL INSTALLATION ON ALL THEIR PRODUCTS



WARNING: When working on, under, or around any vehicle exercise caution. Please allow the vehicle's exhaust system to cool before removal, as exhaust system temperatures may cause severe burns. If working without a lift always consult vehicle manual for correct lifting specifications. Always wear safety glasses and ensure a safe work area. Serious injury or death could occur if safety measures are not followed.

ATTENTION: Always install any supplied band or U-bolt clamps to the proper torque specifications of 40-45 ft-lbs for band clamps and 30-35 ft-lbs for U-bolt clamps. Over tightening will result in the clamp breaking and will NOT be warranted by MagnaFlow.

INSTALLATION INSTRUCTIONS



Step 1. To allow for extraction of the OEM system you must first remove the underside cross brace. Next loosen the clamp at the outlet of the catalytic converter. Working front to rear detach all hangers from rubber insulators and remove the system. Retain rubber insulators and clamp as they will be re-used the mount the new system.

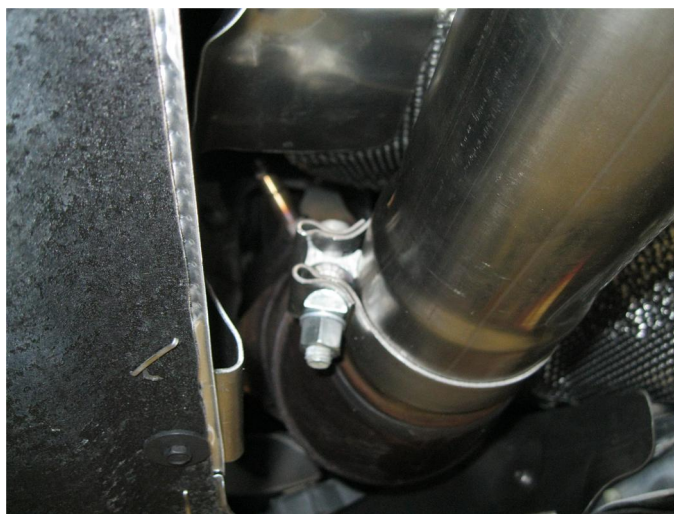

Step 2. Begin installation of the new system by fastening the inlet Y-Pipe Assembly to the outlet of the catalytic converter using the OEM band clamp.

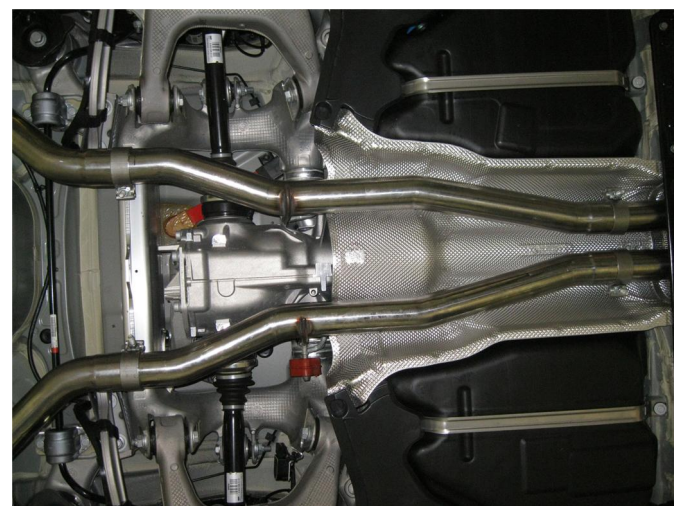
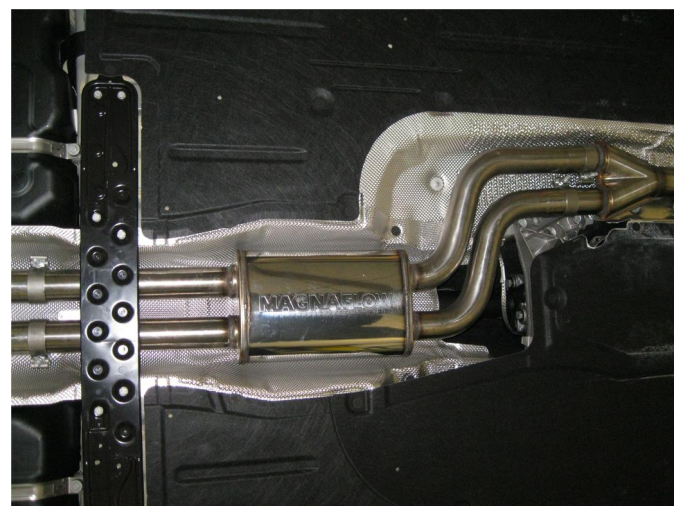

Step 3. Next attach the Resonator Assembly to the Y-Pipe Assembly followed by the two Mid-Pipe assemblies, use supplied clamps and fit hangers into rubber insulators.

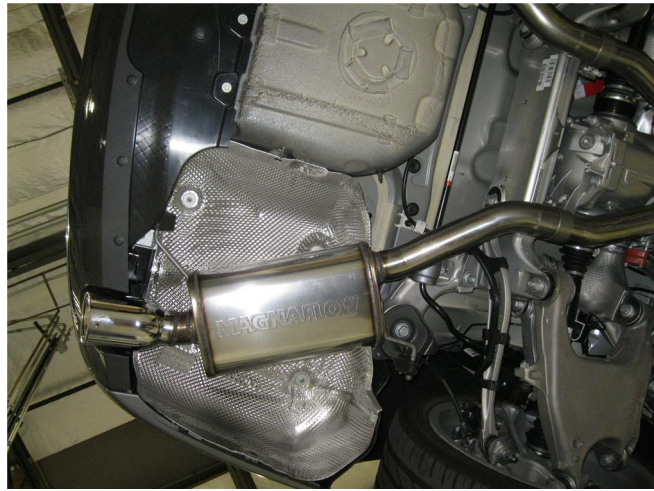

Step 4. Finish by installing both Muffler Assemblies using the supplied clamps, fitting the hangers into the rubber insulators and re-attaching the cross brace.



Step 5. Once a final position has been chosen for the new exhaust system, evenly tighten all clamps from front to rear using the torque specifications on page one of the instructions. Inspect all fasteners after 25-50 miles of operation and re-tighten if necessary.