

2004- Nissan Armada 5.6L V-8

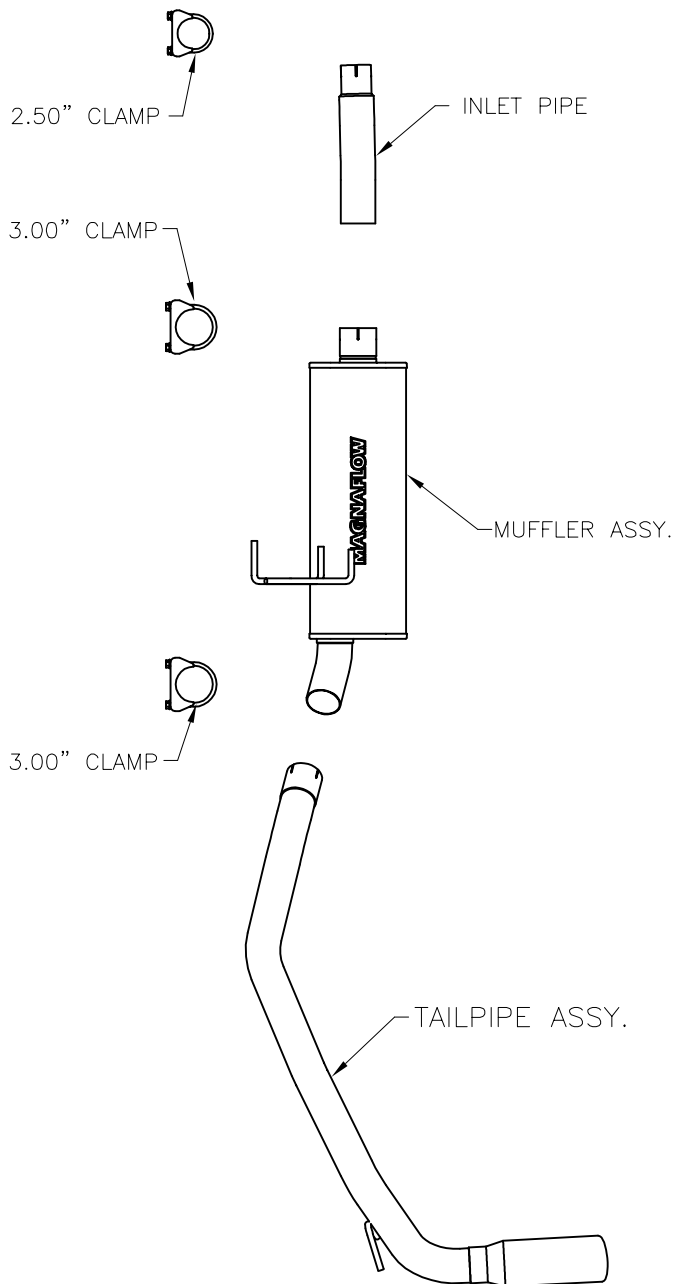

Warning: When working on, under, or around any vehicle exercise caution. Please allow the vehicle's exhaust system to cool before removal, as exhaust system temperatures may cause severe burns. If working without a lift, always consult vehicle manual for correct lifting specifications. Always wear safety glasses and ensure a safe work area. Serious injury or death could occur if safety measures are not followed.

Step 1: (Carefully read all instructions before installation) Disconnect the vehicle's battery before removal of the OEM exhaust. This will allow the computer to reset itself with the new system, and prevent electrical accidents. To remove the OEM system, you will need to cut the OEM tubing approximately 4" behind the factory hanger bracket as shown in Diagram 1. Unbolt the tailpipe and muffler at the mating connections, disengage the welded hangers from the OEM rubber insulators, and remove the assemblies. Do not damage the rubber insulators, as they will be reused to mount the new system. Be sure to deburr the cut tubing to ensure a clean fit with the new inlet pipe.

Step 2: Install the new inlet pipe by fastening it to the previously cut pipe using the supplied 2.50" clamp. Leave all clamps and fasteners loose for final adjustments of the complete system. Install the new muffler by fitting the welded hangers into the OEM rubber insulators and by fastening it to the inlet pipe using a supplied 3" clamp. Install the tailpipe in the same fashion.

*MAGNAFLOW Performance Exhaust recommends professional installation on all their products

Technical support: 1-800-959-9226 ext. 4500

MAGNAFLOW Performance Exhaust - 22961 Arroyo Vista - Rancho Santa Margarita, CA 92688

2004- Nissan Armada 5.6L V-8

DIAGRAM 1



CUT 4" BEHIND
THIS BRACKET

Warning: When working on, under, or around any vehicle exercise caution. Please allow the vehicle's exhaust system to cool before removal, as exhaust system temperatures may cause severe burns. If working without a lift, always consult vehicle manual for correct lifting specifications. Always wear safety glasses and ensure a safe work area. Serious injury or death could occur if safety measures are not followed.

Step 3: With all components mounted loosely, adjust the system for overall aesthetics and clearance of frame & bodywork. (MAGNAFLOW recommends at least 1/2" of clearance between the exhaust system and any body panels to prevent heat-related body damage or fire.)

Step 4: Once a final position has been chosen for the new system, evenly tighten all fasteners from front to rear. Supplied band clamps must be VERY tight to properly align the pipes and prevent leaks (Approximately 65ft-lbs.) U-bolt clamps should be tightened to 30-35ft-lbs. Inspect all fasteners after 25-50 miles of operation and retighten if necessary.