



INSTALLATION INSTRUCTIONS



TOYOTA SUPRA 3.0L

PART NO. 19495

BILL OF MATERIALS:

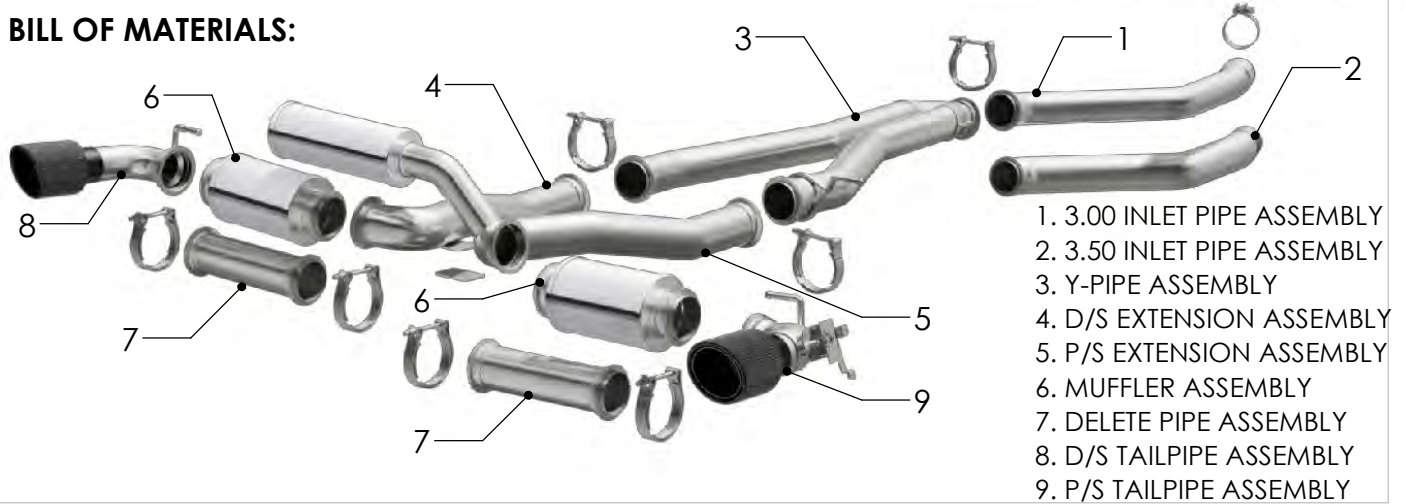

HARDWARE KIT:

- 1.[7] 3.00" V-Clamp
- 2.[1] 3.20 Torca clamp
- 3.[1] MF Bracket
- 4.[4] M6 Bolt
- 5.[4] M6 Nut
- 6.[4] M6 Lock Washer
- 7.[4] M6 Flat Washer

SHOP SUPPLIES:



WEAR SAFETY GLASSES



READ INSTRUCTIONS THOROUGHLY BEFORE INSTALLING PRODUCT



SPRAY LUBRICANT

To ease removal of existing exhaust components (especially on older vehicles) spray penetrating lubricant on all fasteners and hangers/insulators that will be loosened or removed and let soak before disassembly.

MINIMUM REQUIRED TOOLS:



13mm, 15 mm



Hanger Tool (Or Pry Bar)

MAGNAFLOW RECOMMENDS PROFESSIONAL INSTALLATION ON ALL THEIR PRODUCTS



WARNING: When working on, under, or around any vehicle exercise caution. Please allow the vehicle's exhaust system to cool before removal, as exhaust system temperatures may cause severe burns. If working without a lift always consult vehicle manual for correct lifting specifications. Always wear safety glasses and ensure a safe work area. Serious injury or death could occur if safety measures are not followed.

ATTENTION: Always install any supplied band or U-bolt clamps to the proper torque specifications of 40-45 ft-lb for band clamps and 30-35 ft-lb for U-bolt clamps. Over tightening will result in the clamps breaking and will NOT be warranted by MagnaFlow.

MAGNAFLOW: 1901 Corporate Centre Dr - Oceanside, CA 92056 | 1(800)990-0905
Technical Support: 1(800) 959-9226 | Email: moreinfo@magnaflow.com

INSTALLATION INSTRUCTIONS



Step 1. To remove the OEM system first unplug the electrical connector at the exhaust valve located on the passenger side Tail Pipe. Begin by removing the cross brace then unbolt the mounting bracket and loosen the clamp at the exhaust inlet. Remove all welded hangers from the rubber insulators and remove the exhaust. Do not damage the fasteners or rubber insulators as they will be used to install the new MagnaFlow system.

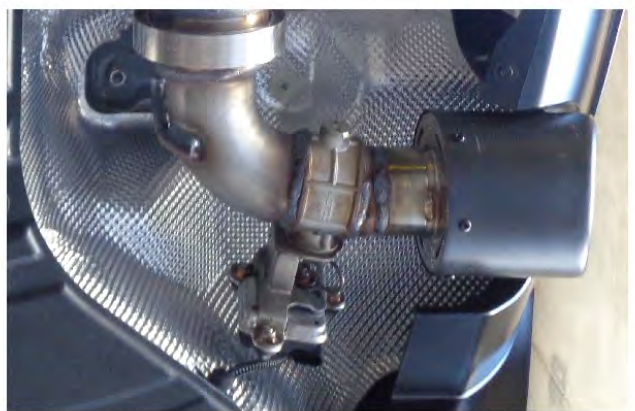

Step 2. Once the exhaust is off the vehicle remove the valve motor from the muffler assembly and transfer it over to the new exhaust valve assembly using the factory hardware.

INSTALLATION INSTRUCTIONS



Step 3. *MagnaFlow supplies this kit with multiple build options giving the ability to use different inlet pipe diameters and delete the mufflers depending on preference.*

Begin installation of the MagnaFlow system by attaching the Inlet Pipe Assembly to the downpipe using the supplied 3.20" clamp and re-using the OE fastener to attach the bracket. Next, attach the Y-Pipe Assembly using one of the supplied V clamps and engaging the hanger into the rubber insulator. (Leave all clamp and fasteners loose for final adjustment of the complete system.)

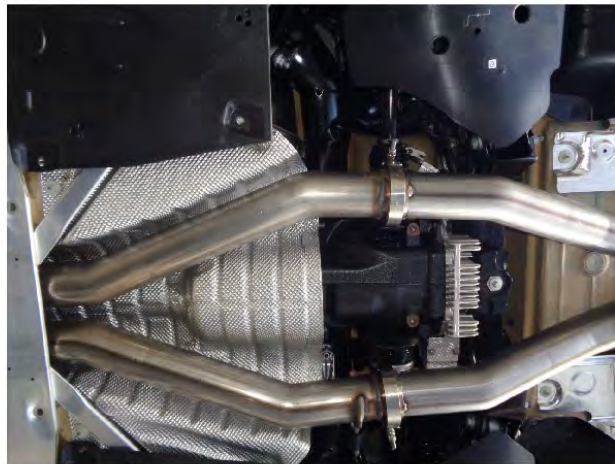

Step 4. Next install the passenger side Extension/Resonator Assembly followed by the driver side Extension pipe using supplied V-Clamps.

INSTALLATION INSTRUCTIONS



Step 5. Install the Muffler Assemblies (or Delete pipes) to the Extension Assemblies then attach the Tip Assemblies to the Mufflers using the supplied V-Clamps. Finish the installation by loosely attaching the MagnaFlow bracket between the Extension Pipes. Re-attach the valve wiring and OE cross brace.



Step 6. Once a final position has been chosen for the new exhaust system, evenly tighten all clamps and fasteners, from front to rear, using the torque specifications on page one of the instructions. Inspect all fasteners after 25-50 miles of operation and re-tighten if necessary.