



## INSTALLATION INSTRUCTIONS

## HEI REMOTE COIL ADAPTER

**Step 1**

Disconnect the battery (-) cable to cut power to the system until installation is complete.

**Step 2**

Disconnect the distributor plug (w/3 wires), 12-volt/ignition switch plug (w/1 wire) and tach lead (if equipped) from the distributor cap. See Figure 1.

**Step 3**

Remove the spark plug wire retainer and the coil cover.

**Step 4**

Remove the HEI coil from the distributor cap. Do not remove the carbon brush with spring or the rubber washer.

**Step 5**

Install the Mallory external coil adapter. Secure using the original coil cover screws. Install the Mallory spark plug wire retainer using the screws provided. See Figure 1.

**Step 6**

Connect the distributor plug and 12-volt/ignition switch plug to the Mallory adapter/harness provided. Continue wiring the Mallory adapter harness as shown in Figure 2 or 3. Connect the battery (-) cable.

FIGURE 1

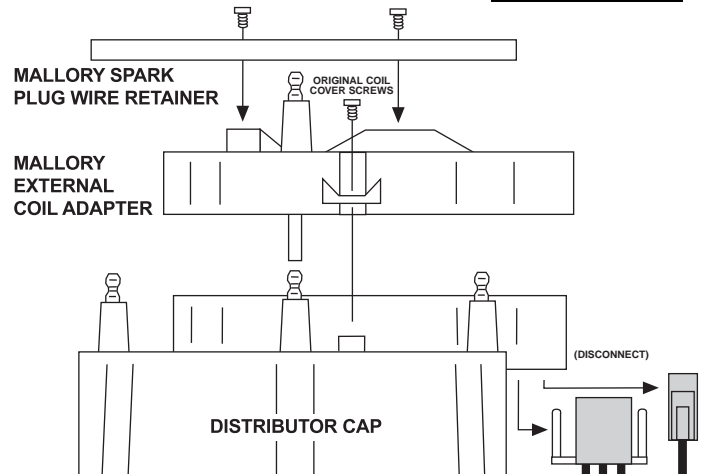
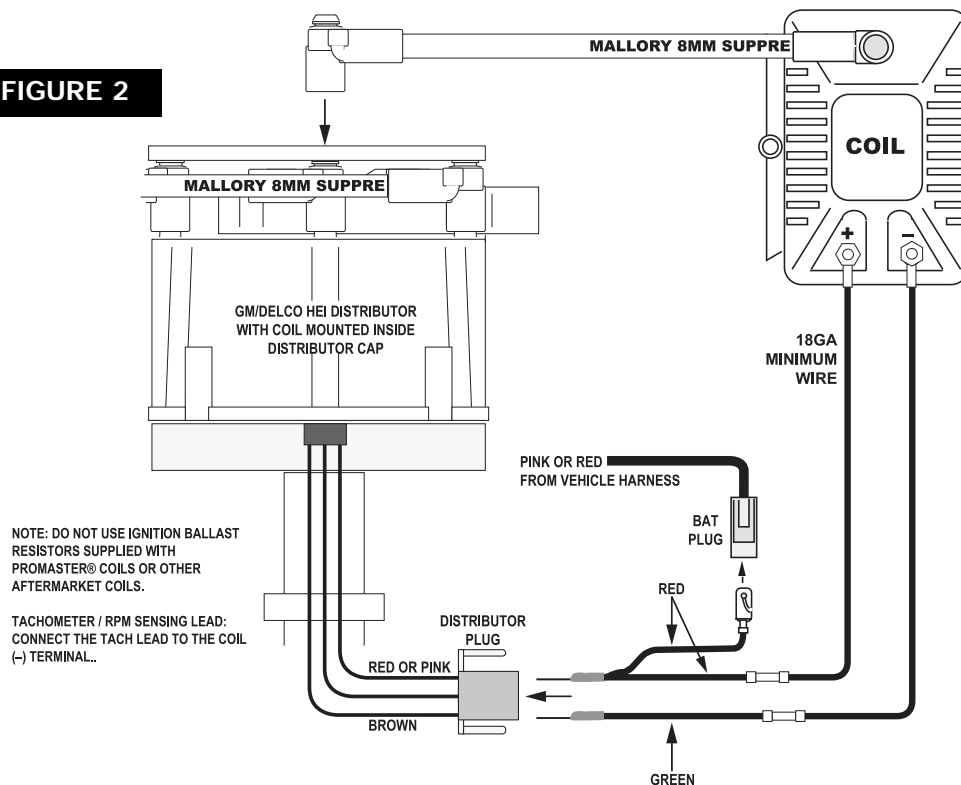
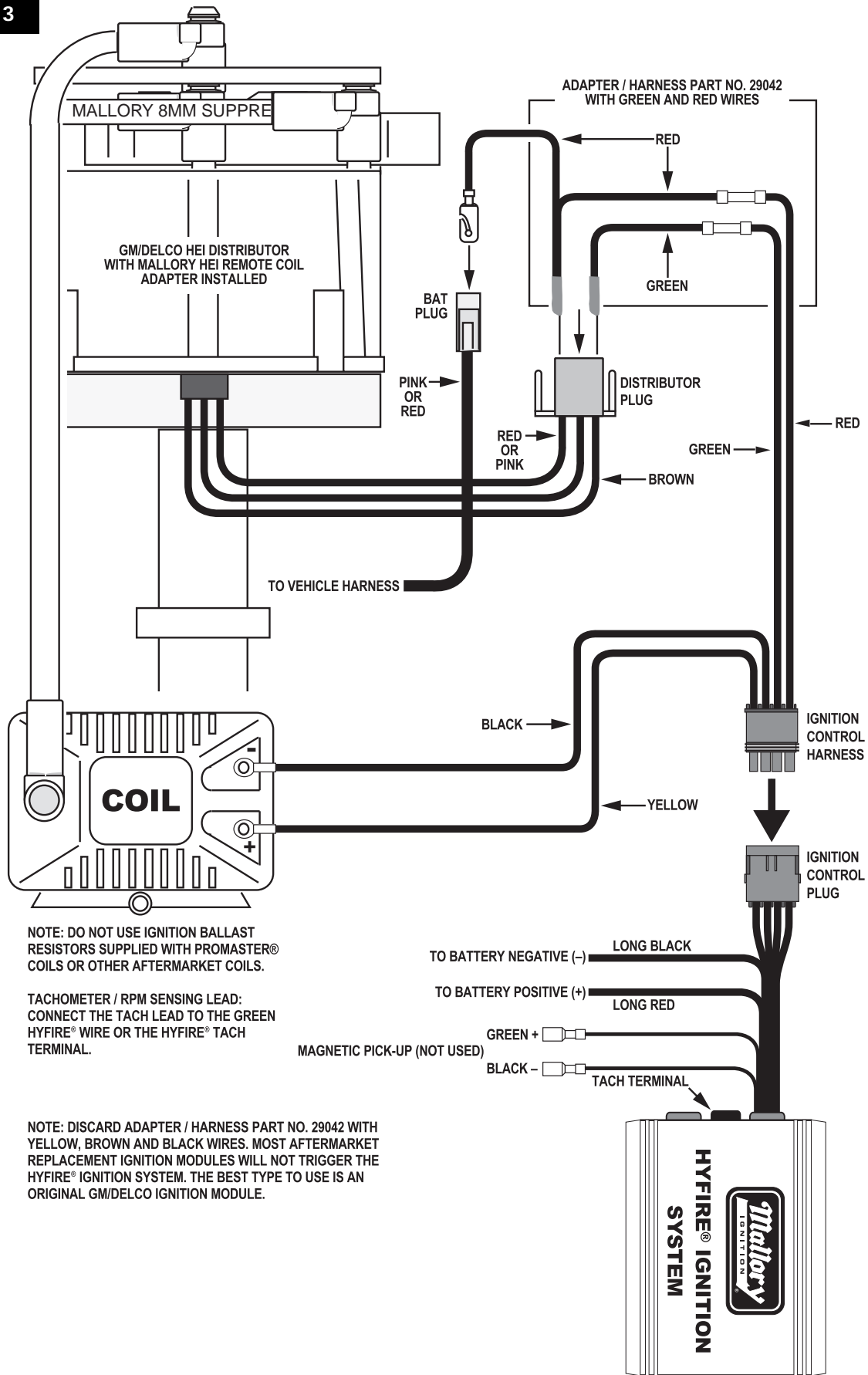

FIGURE 2



**FIGURE 3**



NOTE: DO NOT USE IGNITION BALLAST RESISTORS SUPPLIED WITH PROMASTER® COILS OR OTHER AFTERMARKET COILS.

TACHOMETER / RPM SENSING LEAD: CONNECT THE TACH LEAD TO THE GREEN HYFIRE® WIRE OR THE HYFIRE® TACH TERMINAL.

NOTE: DISCARD ADAPTER / HARNESS PART NO. 29042 WITH YELLOW, BROWN AND BLACK WIRES. MOST AFTERMARKET REPLACEMENT IGNITION MODULES WILL NOT TRIGGER THE HYFIRE® IGNITION SYSTEM. THE BEST TYPE TO USE IS AN ORIGINAL GM/DELCO IGNITION MODULE.