



# INSTALLATION INSTRUCTIONS

## COMP PUMP® SERIES 70 ELECTRIC FUEL PUMP

PART NO. 4070LP

**NOTE: DO NOT RUN THIS PUMP WITHOUT FUEL  
(EXCEPT FOR BRIEF PERIODS WHILE PRIMING).**

This product is covered under one or more of the following U.S. Patents:  
5,007,806; 4,998,557; 5,111,793; 5,123,436; 5,186,147.

### PARTS INCLUDED IN THIS KIT

- 1 Electric Fuel Pump
- 2 Nuts, 5/16" – 24
- 2 Bolts, Steel 5/16"
- 2 Washers, Steel 5/16" Flat
- 1 Splice Connector
- 1 Ring Terminal

### GENERAL INFORMATION

The COMP PUMP® 70 Series Electric Fuel Pump is a low volume fuel pump designed for automotive applications. The operating fuel pressure is factory set at 3-4 PSI. A fuel pressure regulator is not used. We recommend a 5/16" or larger fuel line with this fuel system.

When installing the fuel pump fittings, use a thread sealant compound (you can find this at a hardware store) on the fitting threads. Do not use Teflon tape. Teflon tape can get into the Gerotor and lock the pump. Also, do not overtighten the fittings. This could damage the fuel chamber.

The fuel pump output pressure can be slightly adjusted on the vehicle using a fuel pressure gauge. To change the fuel pump output pressure, release the jam nut and remove bypass plug. Clean the bypass plug. Apply thread sealant compound to the bypass plug threads. Install bypass plug. Turning the bypass plug clockwise increases fuel pressure. Tighten the jam nut.

Be sure to install a suitable fuel filter (minimum 40 micron filtration) between the fuel tank and the fuel pump. The Mallory COMP FILTER® Series Part Nos. 3140 is recommended. This prevents debris from becoming wedged in the fuel pump's Gerotor and locking it.

### SPECIFICATIONS

- Operating pressure: 3-4 PSI
- Fuel pump inlet/outlet thread sizes: 3/8" NPT
- Oil pressure switch rating: 5 AMP
- Fuel pump over current protection: 5 AMP fuse
- Fuel applications: Gasoline

**Service Parts**      PN 3146A Brush Kit  
                                 PN 3164 Seal/Repair Kit, Gasoline

### MOUNTING PROCEDURE

#### Step 1

Mount the pump as close as possible to the fuel tank (at or below the level of the fuel tank pickup) in a well ventilated area with minimal exposure to road debris. Avoid exposing the pump and fuel lines to moving parts and hot surfaces, such as the exhaust system. **NOTE: Increasing distance between the pump and tank will decrease pump efficiency.**

#### Step 2

Using the pump mounting bracket as a template, locate mounting holes on a solid member, such as the vehicle chassis. Drill holes for 5/16" bolts. See Figure 1. **NOTE: To ensure against a potential fire hazard from pump flooding, mount the pump in a vertical position with the motor on top.**

#### Step 3

Connect fuel lines as shown in Figure 2. If your fuel system requires a fuel pressure regulator, proceed to the instructions with the fuel pressure regulator.

## WIRING PROCEDURE

Wiring the pump to an oil pressure switch will provide power only when the ignition switch is on and the engine is running. This will prevent the pump from running if your engine stalls. Use 14 gauge wire or larger and be sure to disconnect the battery ground cable before wiring the pump. Refer to Figure 3 when connecting the pump to an oil pressure switch.

The pump may be wired directly to the ignition switch "ON" terminal and grounded to the frame or battery. Refer to Figure 4 when connecting the pump to the ignition switch "ON" terminal.

## MAINTENANCE—PUMP DISASSEMBLY

If your pump fails to produce adequate pressure, it may require cleaning. Follow the steps below to disassemble and clean your Mallory Electric Fuel Pump. Refer to Figure 5 while performing the following steps.

### Step 1

Remove the pump from the vehicle and clean pump exterior. Place the pump on its side on a clean work surface. Scribe or draw a line across the pump housing, port plate and fuel chamber so that you can reassemble the pump correctly.

### Step 2

Remove the two fuel chamber screws from the bottom of the pump. Remove the fuel chamber and port plate. **NOTE: Do not drop the Gerotor from the pump cavity.**

### Step 3

Separate the port plate from the fuel chamber. Inspect the flame arrestor screen in the fuel chamber and clean it if necessary.

### Step 4

Place your hand beneath the Gerotor and hold the pump in an upright position. The Gerotor should slide out of the pump housing and into your hand. **NOTE: Observe the position of the Gerotor and be careful not to reverse it when you reassemble the pump.**

### Step 5

Release the jam nut on the bypass plug. Mark the bypass plug location and count the number of turns required to remove it. Remove the bypass spring and plunger. Inspect the plunger. The plunger surface should be clean and slide freely in the chamber. Check the plunger pad and remove any debris embedded in its surface. Reinstall the bypass spring and plunger. Clean the bypass plug. Apply thread sealant compound to the bypass plug threads. Install the bypass plug. Tighten the jam nut.

### Step 6

Clean the Gerotor and install it in the pump housing. Inspect the o-ring and gasket. Replace them if necessary. Place the gasket and port plate on the fuel chamber. Install the fuel chamber assembly on the pump housing. Torque the fuel chamber screws to 24 in/lbs.

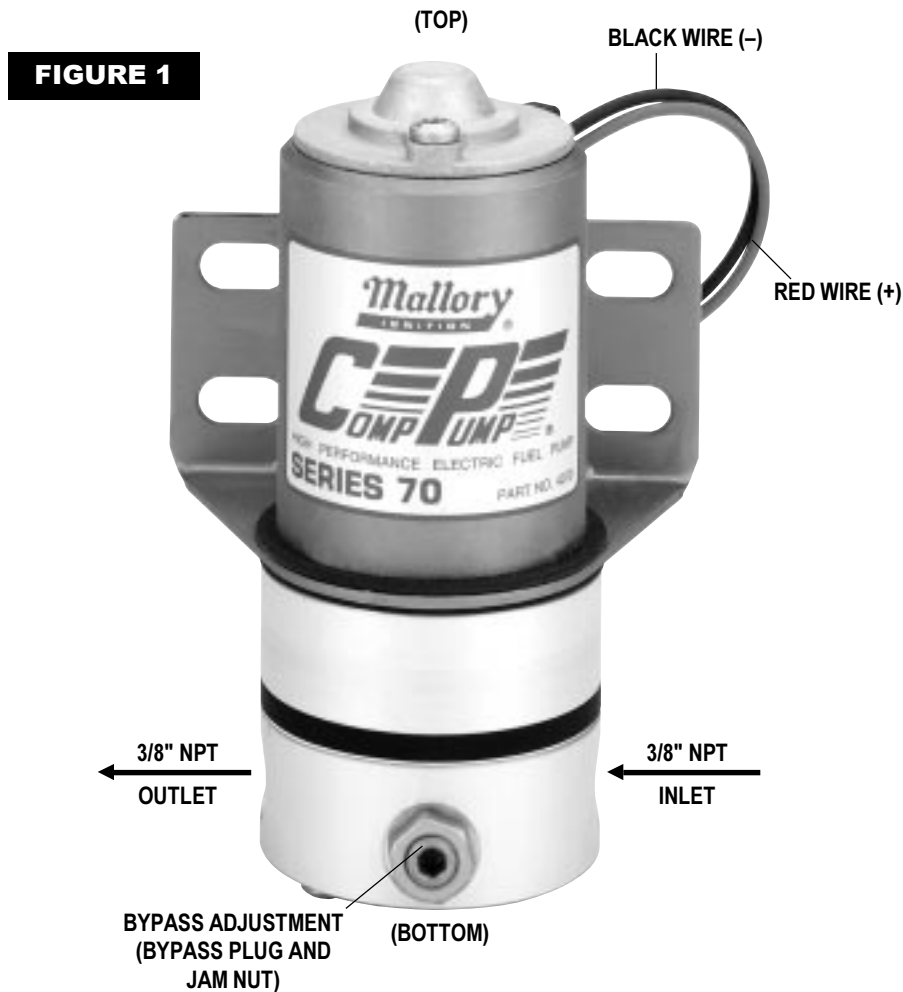

**FIGURE 2**

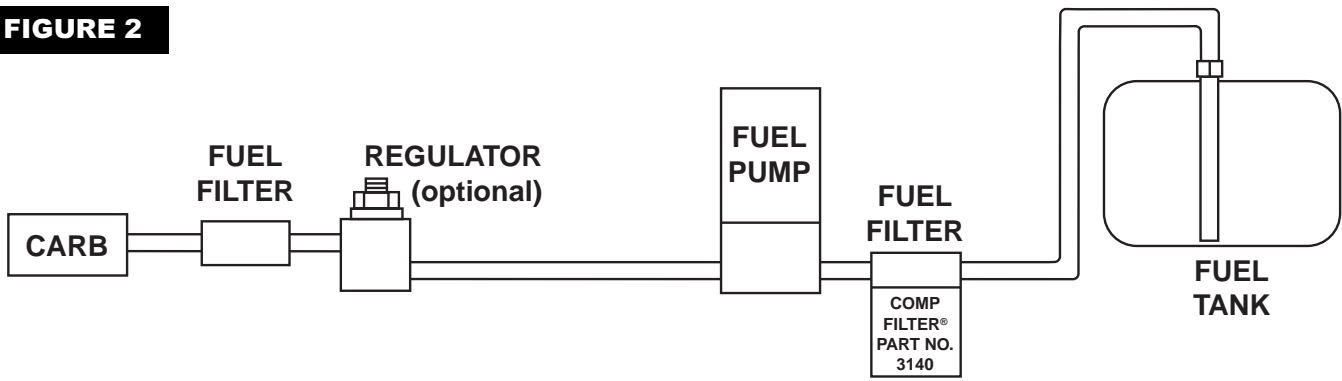

**FIGURE 3**

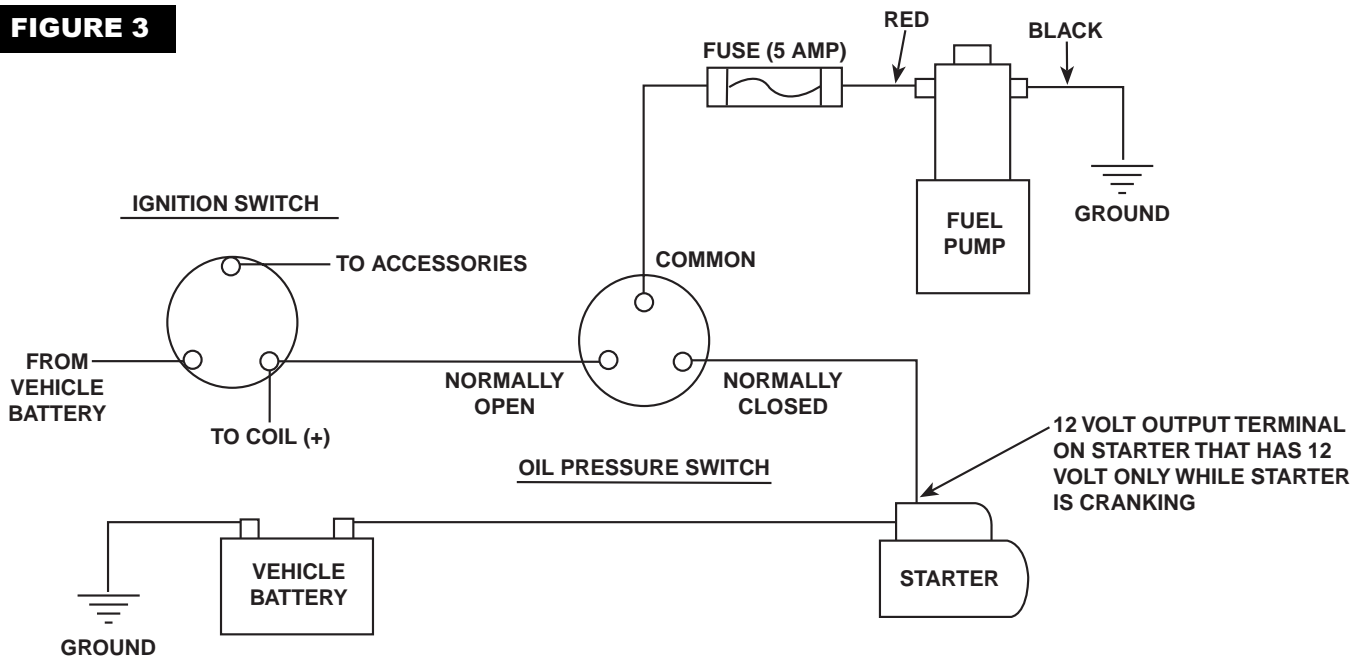

**FIGURE 4**

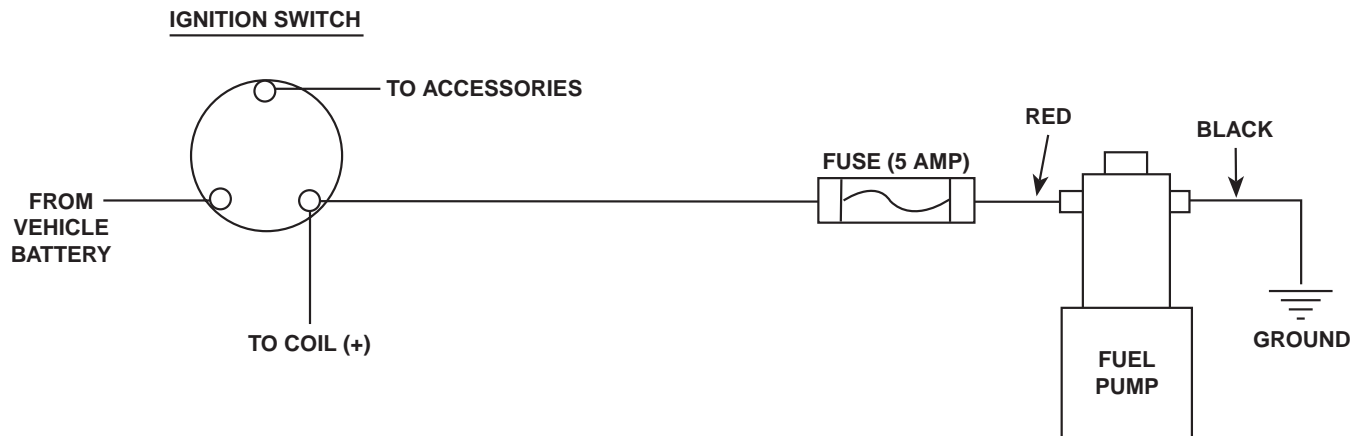

**FIGURE 5**

