



## INSTALLATION INSTRUCTIONS

# E-SPARK™ CONVERSION PART NO. 61002M

**IMPORTANT:** Before installing the E-Spark™ Ignition System, make sure that your vehicle is equipped with an ignition ballast resistor (or loom resistance wire) in the wire between the ignition switch and the coil (+) terminal. One easy way to find the ignition ballast resistor is to check the service manual for your vehicle. You can test your stock ignition system voltage while the engine is at idle at the coil (+) terminal. If the measured voltage is within 1-volt of battery voltage, an ignition ballast resistor must be installed in the wire from the ignition switch. In general, all vehicles equipped with the Ford point ignition were equipped with an ignition ballast resistor. If you find your vehicle is not equipped with an ignition ballast resistor, install a Mallory Ignition Ballast Resistor Part No. 700 in series in the wire from the ignition switch. Failure to use an ignition ballast resistor will result in the eventual destruction of the E-Spark™ Ignition Module.

**Exceptions:** 1) Using one of Mallory's 3 specially matched coils eliminate the need for a ballast resistor or a resistance wire. These coils are: 29219- Chrome Canister Coil, 30450 PROMASTER e Coil and 29450 PROMASTER Classic Coil.

2) If your vehicle is equipped with a HyFire Electronic Ignition Control or similar aftermarket ignition control, use the wiring specified for the particular controller, along with its matching coil, such as Mallory's 29440 or 30440.

**NOTE:** This kit can be installed in the distributor without removing the distributor from the engine if the distributor is easily accessible. However, removal of the distributor from the engine is recommended.

### PARTS INCLUDED IN THIS KIT

1 E-Spark™ Module	1 Cable Tie
1 Rotor/Shutter	2 Screws, 6-32 x .18
1 Distributor Wire Harness	2 Screws, 8-32 x .25
1 Female Connector	1 Screw, 8-32 x .375
2 Mounting Plates	1 Grommet
1 Capsule, Silicone Grease	

### GENERAL INFORMATION

#### Ignition Coils:

The E-Spark™ Ignition System is designed to work with most stock ignition coils and aftermarket high performance ignition coils. For optimum performance in systems without a HyFire or similar ignition control, use one of Mallory's 3 specially matched coils eliminates the need for a ballast resistor or a resistance wire. These coils are: 29219- Chrome Canister Coil, 30450 PROMASTER e Coil and 29450 PROMASTER Classic Coil.

#### Spark Plug Wires:

To prevent false triggering and the possibility of premature ignition failures, use suppression type spark plug wire. We recommend spiral core ignition wire, such as Mallory PRO SIDEWINDER® Ignition Wire.

#### Spark Plug Gaps:

For street applications, use your engine manufacturer's specifications. For racing applications, start with your engine manufacturer's specifications, then experiment with and closely monitor various gaps to achieve maximum performance.

#### Electric Welding:

Unplug the distributor wire harness before welding on the vehicle.

#### Optional Circuit Guard Part No. 29371:

Voltage spikes (voltage transients, power surges) are associated with "noisy" electrical systems from electrical defects such as worn alternator brushes, corroded or oxidized electrical connections and similar electrical problems. Voltage spikes damage the E-Spark™ Ignition Module. Voltage spikes are clamped and regulated by the optional Circuit Guard from damaging the E-Spark™ Ignition Module.

### INSTALLATION PROCEDURE

#### Step 1

Disconnect the point trigger wire from the coil (-) terminal.

#### Step 2

Locate the spark plug wire on the distributor cap that the engine timing is set from. See a service manual for these locations. Mark the distributor housing, in line with this spark plug wire position on the distributor cap.

#### Step 3

Turn the engine crankshaft until the timing mark lines up with the TDC (top dead center) mark on the timing tab. See a service manual for these locations.

**NOTE:** Removing the spark plugs may make it easier to turn the crankshaft.

#### Step 4

Remove the distributor cap from the distributor and lay it aside. Do not remove the spark plug wires or coil wire. The rotor blade should point to the mark made on the distributor housing (from Step 2). If it is not, turn the engine crankshaft one full turn (repeating Step 3) until the timing mark lines up (again) with the TDC mark on the timing tab.

**NOTE:** Once you are finished with Step 4, DO NOT turn the crankshaft until the distributor is installed – Step 12.

#### Step 5

Note the direction the rotor is pointing. Note the direction the vacuum chamber is pointing. Disconnect the vacuum chamber hose at the carburetor and temporarily plug this carburetor fitting. Remove the distributor hold down clamp and remove the distributor from the engine.

#### Step 6

Remove the rotor. Disconnect the primary point wire. Remove the primary wire and grommet from the distributor. Remove the points and the condenser from the breaker plate.

#### Step 7 (See Figure 1)

Position the lower mounting plate (with one countersunk hole) against the breaker plate. Align the countersunk hole over one existing breaker plate threaded hole. Align one non-threaded hole with the other breaker plate threaded hole. Install one 8-32 x 3/8" flathead screw through the non-threaded hole (temporarily, do not tighten) to help in the alignment of the lower mounting plate onto the breaker plate. Install one 8-32 x 1/4" flathead screw through the countersunk hole and tighten firmly into the breaker plate. Remove the 8-32 x 3/8" flathead screw.

#### Step 8

Position the upper mounting plate with its countersunk holes aligned with the holes in the lower mounting plate. Install one 8-32 x 3/8" flat-head screw through the non-threaded hole in the lower mounting plate into the breaker plate. Install one 8-32 x 1/4" flathead screw into the threaded hole in the lower mounting plate. Make sure to tighten these screws firmly.

#### Step 9

Apply a thin coat of white silicone grease to the bottom of the E-Spark™ Module. Install the E-Spark™ Module onto the upper mounting plate with two 6-32 screws. Make sure to tighten these screws firmly.

### Step 10

The grommet has a flat on one flange. Install the grommet in the hole in the distributor housing where the primary wire had previously fed through with the flat on one flange facing out and up. Positioning the flat on one flange facing out and up allows adequate distributor cap clearance. Slide the three wires from the E-Spark™ Module, through the grommet, to outside the distributor housing.

### Step 11 (See Figure 2)

Put the E-Spark™ Module's three wires in the female connector:

- GREEN WIRE in hole #1
- BROWN WIRE in hole #2
- RED WIRE in hole #3

Plug the female connector into the distributor wire harness. See Figure 2.

### Step 12

Install the rotor/shutter. Place the distributor in the engine with the rotor pointing in the same general direction as during removal of the distributor (from Step 5).

**NOTE: The distributor must be fully seated into the engine. It may be necessary to turn the oil pump drive, or turn the engine crankshaft in the direction of rotation two full turns until the timing mark lines up (again) with the TDC mark on the timing tab to allow the distributor to seat fully.**

### Step 13

Rotate the distributor housing until the rotor points to the mark on the distributor housing (from Step 2) and the nearest slot on the rotor's shutter wheel is approximately in the center of the optics of the E-Spark™ Module. This will generally put timing close enough for starting purposes. Put the distributor hold down clamp in place and tighten slightly, leaving it loose enough to turn the distributor housing.

### Step 14

Install the distributor cap.

**NOTE: The grommet was installed during step 10. The grommet has a flat on one flange. When installed, the flat on the flange of the grommet must face out and up to allow adequate distributor cap clearance. The distributor cap may not sit properly on the distributor housing unless these details are followed exactly.**

## WIRING PROCEDURE

(See Figures 3, 4 and 5)

**IMPORTANT:** Make sure that your vehicle is equipped with an ignition ballast resistor (or loom resistance wire) in the wire between the ignition switch and the coil (+) terminal. One easy way to find the ignition ballast resistor is to check the service manual for your vehicle. In general, all vehicles equipped with the Ford/Motorcraft point ignition were equipped with an ignition ballast resistor. If you find your vehicle is not equipped with an ignition ballast resistor, install a Mallory Ignition Ballast Resistor Part No. 700 in series in the wire from the ignition switch. Failure to use an ignition ballast resistor will result in the eventual destruction of the E-Spark™ Ignition Module. Exception: If your vehicle is equipped with a HYFIRE® Electronic Ignition Control or similar aftermarket ignition control, use ignition ballast resistors and wiring procedures as stated in the instructions for the particular ignition control.

**NOTE: If your vehicle is equipped with a HYFIRE® Electronic Ignition Control or similar aftermarket ignition control, use ignition ballast resistors and wiring procedures as stated in the instructions for the particular ignition control.**

## ADDITIONAL CONNECTIONS

Tachometer operation: Connect tachometer wire or wires as recommended by the actual tachometer manufacturer.

## STARTING ENGINE

**CAUTION: Be sure all tools, wires and miscellaneous objects are clear of moving engine parts and extreme heat before starting the engine.**

### Step 1

Recheck all wires and connections to make sure they are correct. Check and clean, or replace, spark plugs. If replacing spark plugs, use types recommended by the engine manufacturer.

### Step 2

Connect a timing light. Find the area with the best view of the timing marks.

### Step 3

Start the engine. If it fails to start, rotate the distributor housing in small increments clockwise or counterclockwise until engine starts. Do not exceed more than 10 degrees of distributor housing rotation in either direction.

### Step 4

Set timing as recommended by engine manufacturer, then tighten distributor hold down clamp. Make sure timing is still correct. If timing has moved, repeat this procedure. Re-connect vacuum line.

DISTRIBUTOR TUNE-UP PARTS	PART NO.
DISTRIBUTOR CAP	217
ROTOR/SHUTTER WHEEL	333
E-Spark™ MODULE	6100M

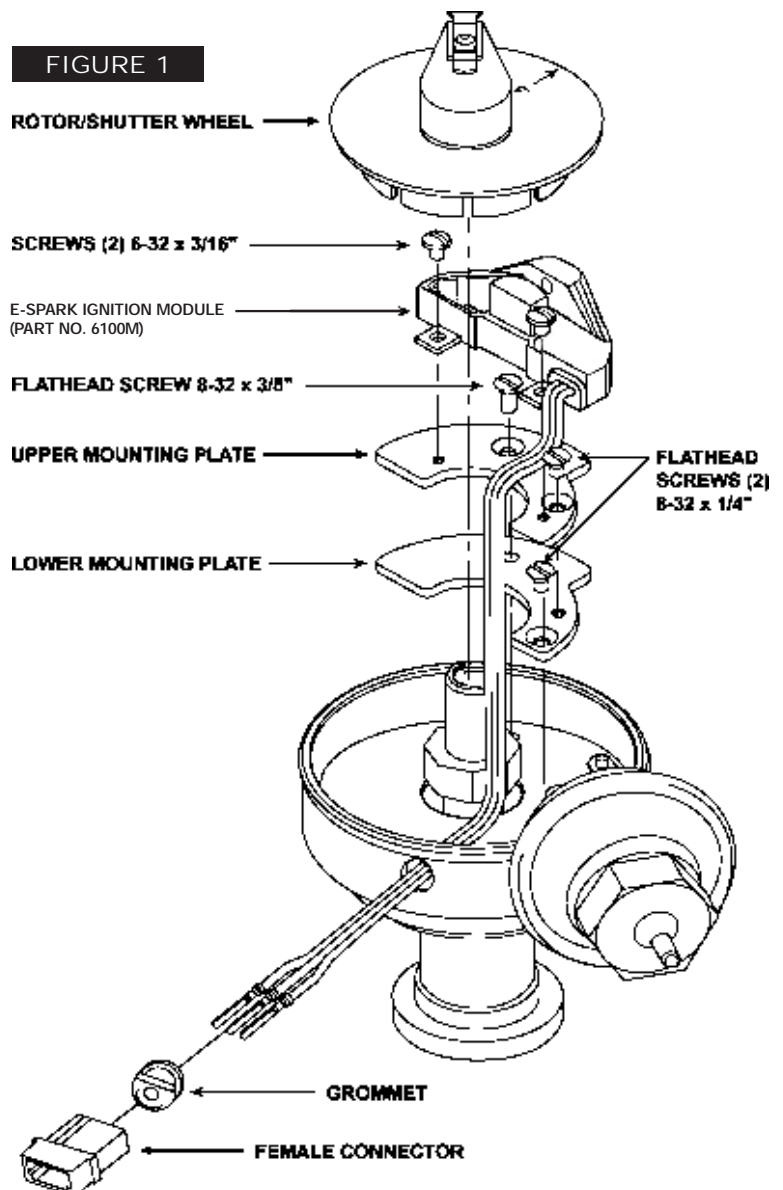

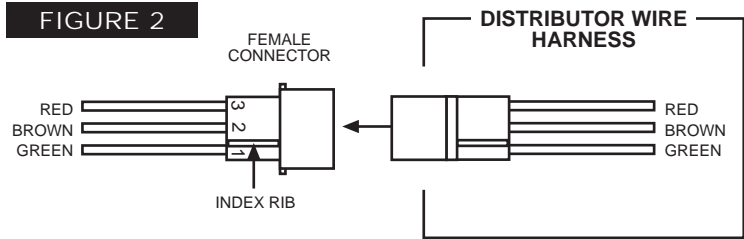

**FIGURE 3**

**E-SPARK™ WIRING DIAGRAM USING 12V IGNITION FEED AND A MALLORY 29219, 30450 OR A 29450 PERFORMANCE IGNITION COIL**

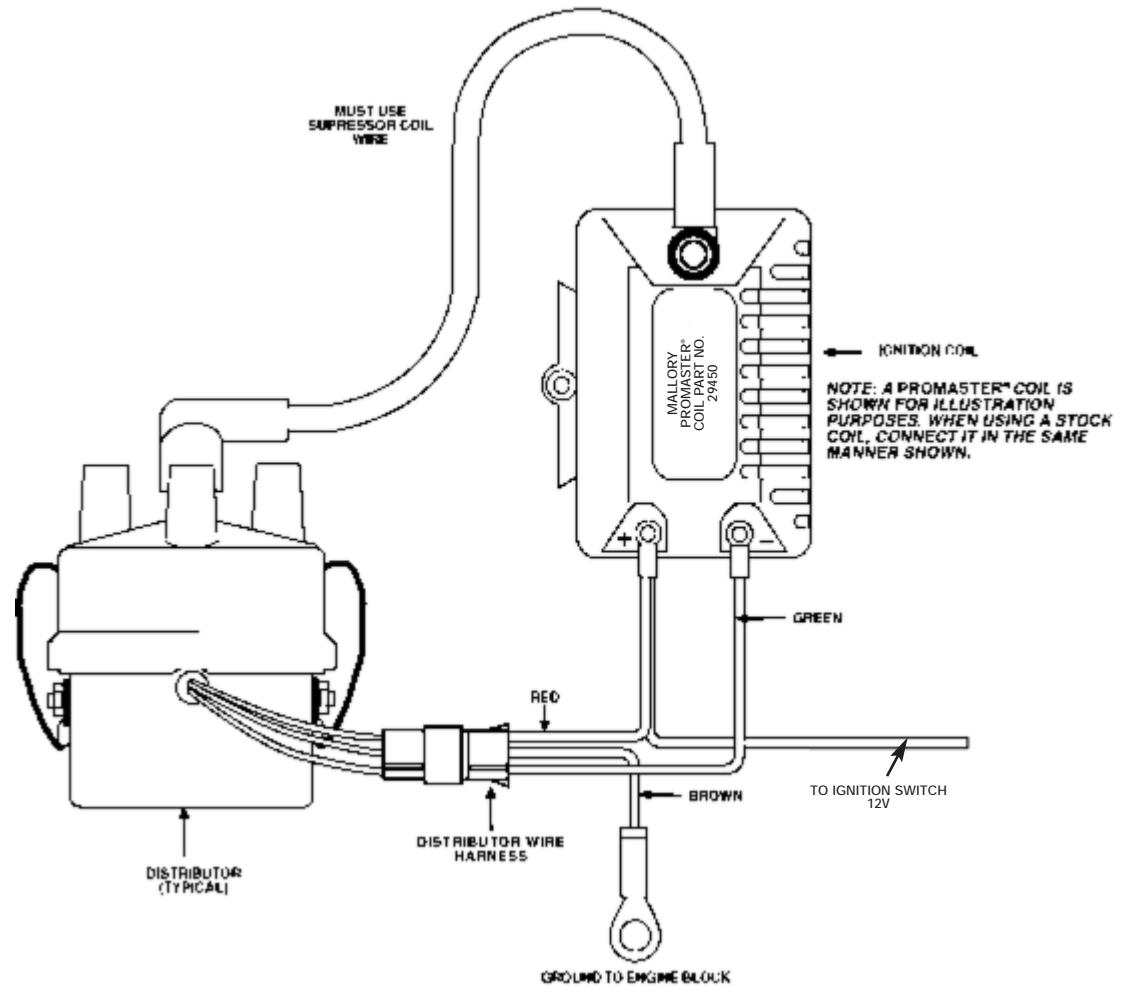

FIGURE 4

# E-SPARK™ WIRING DIAGRAM USING OEM PRIMARY RESISTANCE WIRE

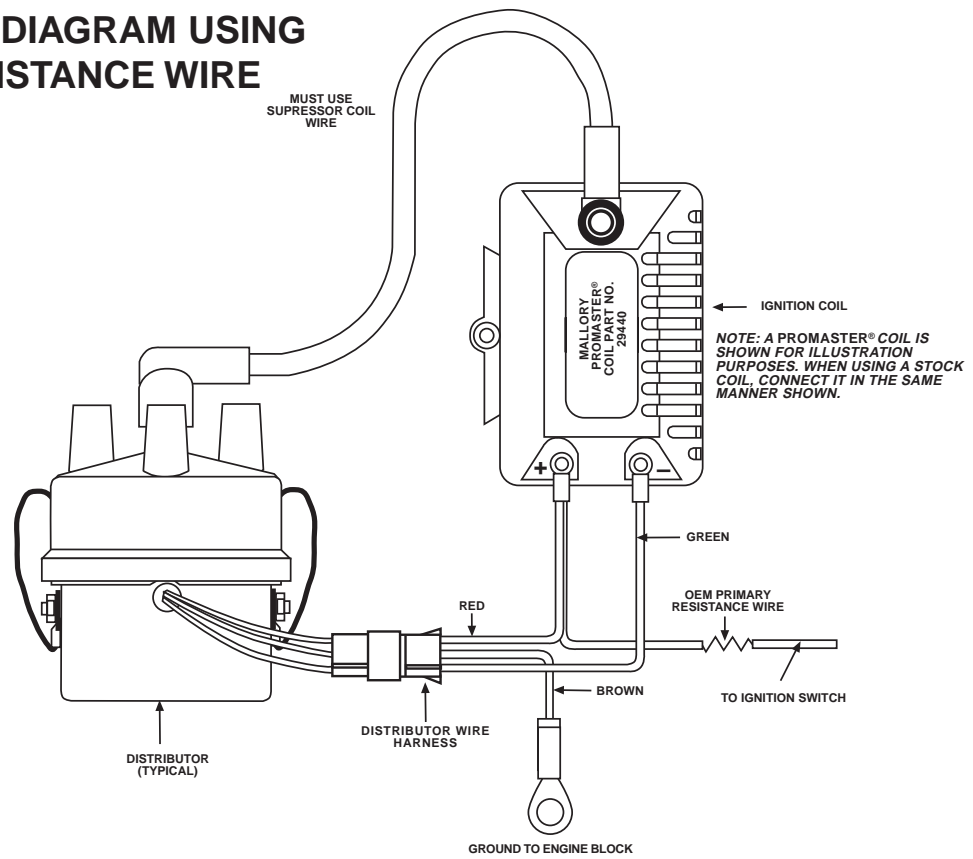
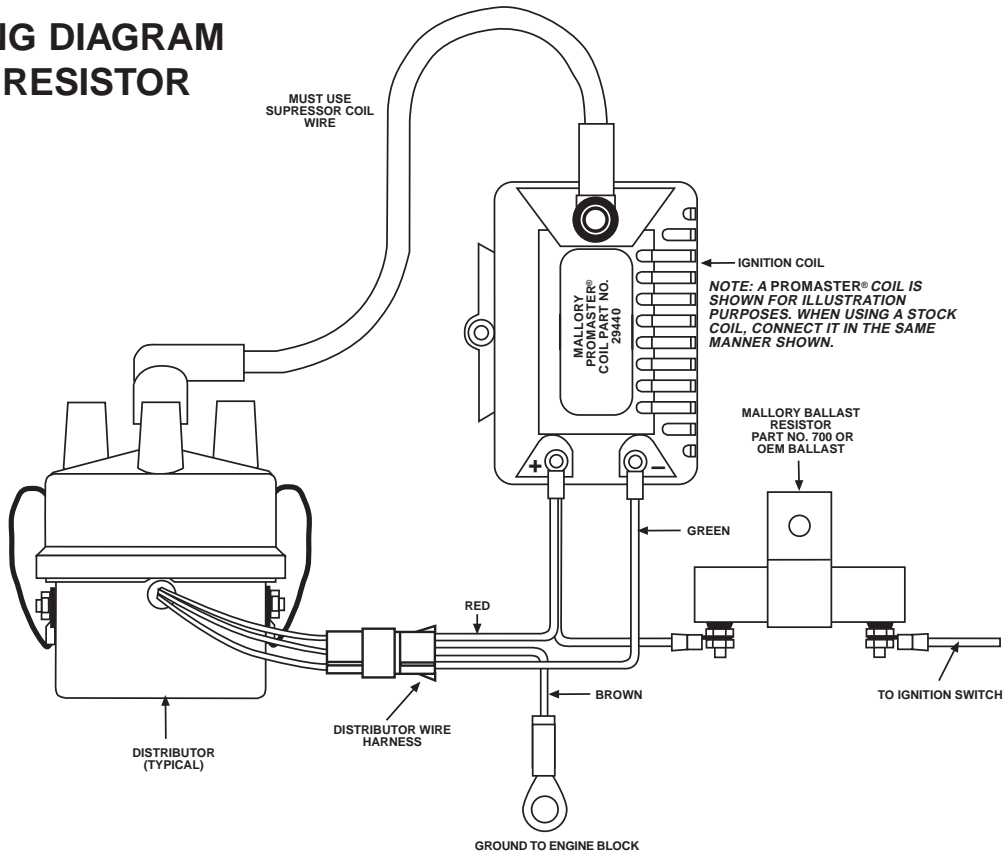

FIGURE 5

# E-SPARK™ WIRING DIAGRAM USING BALLAST RESISTOR



MALLORY IS A DIVISION OF THE MR. GASKET PERFORMANCE GROUP  
10601 MEMPHIS AVE. #12, CLEVELAND, OH 44144  
216.688.8300 FAX 216.688.8306

FORM 1580  
12/03  
Made in U.S.A.  
Printed in U.S.A.