

## Bell Housing Alignment Procedure

When swapping a clutch, bell housing or transmission it is highly recommended you check the alignment of the bell housing to the engine block/crankshaft and to the transmission input shaft/output shaft. Think of this as a theoretical straight line running through the crankshaft, through the input shaft of the transmission and the output shaft of the transmission. Misalignment along this path can lead to leaks, poor clutch release, premature wear of components and excessively noisy operation. This inspection can be performed with a few common measuring devices and some time. Manufacturer's tolerances of engine/crankshaft alignment can vary

especially if the engine block has been modified throughout its lifetime or if you are performing a bell housing and/or transmission swap. If you find excess misalignment on your engine/bell housing you can correct the problem with off-set dowel pins. (Lakewood Industries offers Offset dowel Pins to correct misalignment conditions). You will need a dial indicator with a magnetic base along with some typical hand tools to perform this inspection. It is critical you pay close attention to detail when performing this inspection in order to achieve accurate assembly results.

- 1) Install flywheel onto crankshaft, using proper bolts and torque to factory setting.
- 2) Be certain the engine block dowel pins stick out of the rear of the engine block at least 3/8" for proper bell housing engagement. Check the rear surface of the engine block at this time to be certain it is free of nicks or burrs that will prevent the bell housing from seating against the block.
- 3) Install just the bell housing and hold in place with a few bolts. Install dial indicator base onto crank flange or flywheel face and adjust plunger to contact the register bore of the bell housing. Rotate the crankshaft and note the indicator reading as you sweep the register bore of the bell housing.
- 4) Misalignment can be determined by dividing the change in the indicator by 2. Maximum allowable runout is .005".
- 5) If your reading exceeds .005" off set dowel pins must be used to correct the misalignment. Lakewood Industries offers such dowel pins in several sizes.

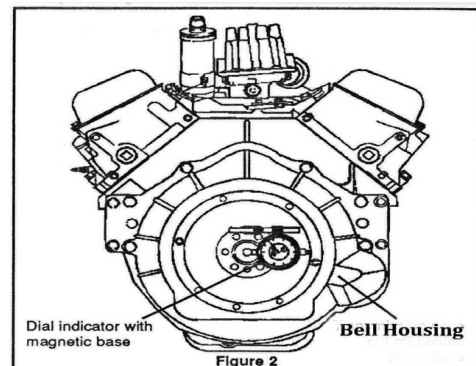
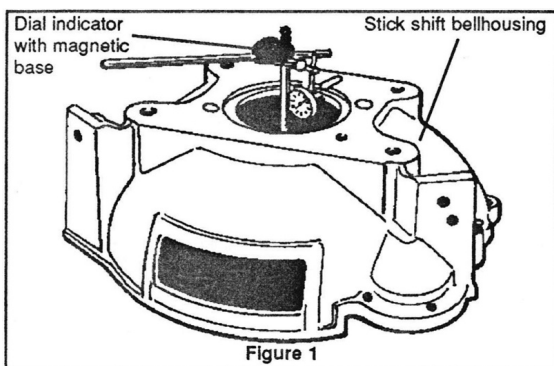

**This alignment procedure will eliminate premature wear on many of the transmission and clutch related components and will provide smoother operation.**

## Limited Warranty

McLeod Racing LLC, products are warranted to be free from defects in material and workmanship for the period of ninety (90) days, from the date of purchase. McLeod does not warrant or make any representations concerning its products when not installed and/or used strictly in accordance with the manufacturer's instructions for such; installation and operation, and in accordance with good installation and maintenance practices of the automotive industry. Products purchased used do not carry a warranty. This warranty is to the original purchaser and is non-transferable.

McLeod Racing LLC will not be held liable for the labor charges and other intangible or consequent losses that might be claimed as a result of the failure of any part, nor shall it be liable for damages or injury to persons or property resulting from the misuse or improper installation of any part subject to this warranty.

No merchandise may be returned for any reason unless prior return merchandise authorization number (RMA) has been obtained from McLeod. An RMA number may be obtained via [www.mcleodracing.com](http://www.mcleodracing.com) or by calling McLeod directly.

McLeod Racing LLC reserves the right to examine all parts returned for warranty claim to determine whether or not any such part has failed because of a defect in material or workmanship. McLeod's obligation under this warranty shall be limited to repairing, replacing or crediting, at its option, any part found to be defective. All products returned to McLeod for warranty inspection must be prepaid by the customer under this warranty.

In a racing environment, the type of stress placed on automotive parts can vary dramatically by the type of use, driving style, track preparation, differing tire style and other variables that are out of McLeod's control. For this reason, any parts used in a racing environment shall be void of any warranty either expressed or implied.

There are no other warranties, either expressed or implied including, but not limited to, warranty of merchantability, and warranty of fitness for a particular purpose which extend beyond those set forth in the preceding paragraphs. This warranty shall be interpreted and applied in accordance with California law.

For any changes or updated versions of the warrant described above, please refer to [www.mcleodracing.com](http://www.mcleodracing.com) before installation of product.