

# S5500

2000-06 JEEP WRANGLER/RUBICON (TJ),  
2.5L I-4 & 4.0L I-6, CAT BACK, SINGLE SIDE

# MBRP INC.

**PERFORMANCE EXHAUST**

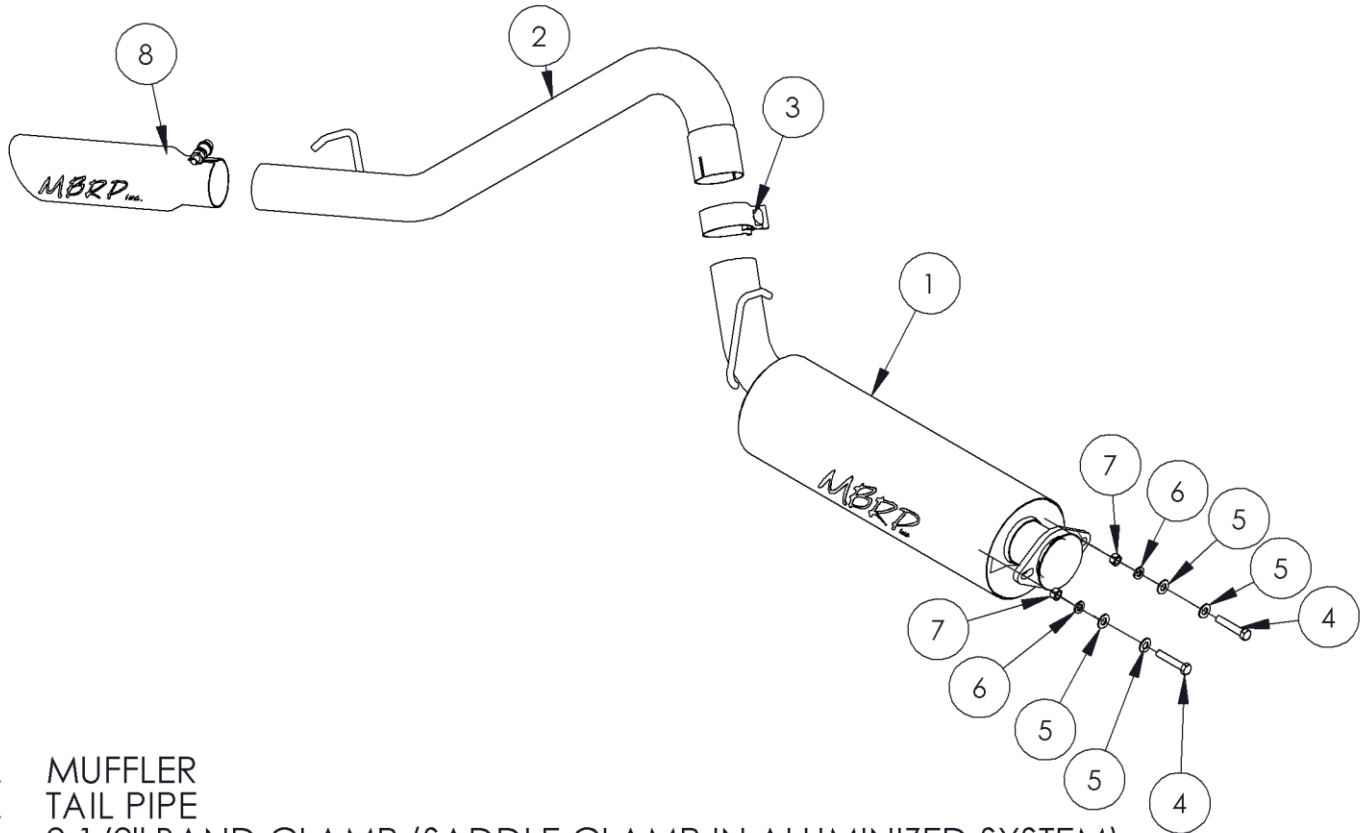

1. MUFFLER
2. TAIL PIPE
3. 2 1/2" BAND CLAMP (SADDLE CLAMP IN ALUMINIZED SYSTEM)
4. 3/8" X 2" BOLT (2PCS)
5. 3/8" WASHER (4PCS)
6. 3/8" LOCK WASHER (2PCS)
7. 3/8" NUT (2PCS)
8. EXHAUST TIP

## PLEASE READ BEFORE STARTING INSTALLATION

While MBRP Inc. has made every effort to ensure that all components of this system are of superior quality and properly packaged, it is the installer's responsibility to ensure the following before removal of the factory exhaust:

- that ALL components shown above are present.
- that ALL mating components fit together.
- that there are no damaged components.
- that the system you have purchased is appropriate for your vehicle year, model and configuration.
- that the system will not interfere with any modifications previously installed or planned.
- that you have read and understand these instructions.

If you have any questions or are uncertain about any aspect of the installation of this system to your vehicle please contact your dealer before commencing installation.

## 2000-2006 Jeep Wrangler/Rubicon (TJ)

### Removal of stock system:



**Figure 1**

1. Apply a penetrating lubricant liberally to all exhaust fasteners, hangers and rubber insulators.

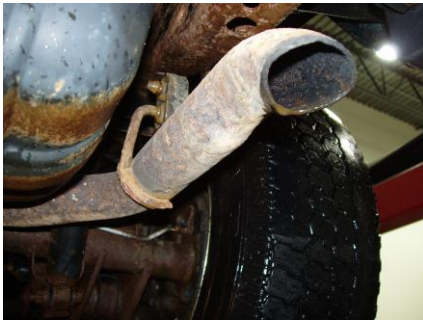

**Figure 2**

2. Cut the exhaust pipe after the muffler to be able to remove it from the vehicle. **Refer to Figure 1.**

3. Remove the tail section of the exhaust by removing it from the rubber isolators. **Refer to Figure 2.**



**Figure 3**

4. Remove the hardware from the flange and remove the muffler. **Refer to Figure 3.**

**Installation of MBRP Inc. Performance Exhaust:**



**Figure 4**

1. Install the **Muffler** to the existing flange using the fasteners provided. Slide the **Muffler** hanger into the existing rubber isolator. Refer to **Figure 4**.



**Figure 5**

2. Slide a 2 ½” **Clamp** over the **Muffler** outlet then install the **Tail Pipe** to the **Muffler**. Install the **Tail Pipe** hanger into the existing rubber isolator. Refer to **Figure 5**.

3. Install and adjust the **Exhaust Tip** to suit. Tighten the lock bolt located on the **Exhaust Tip**. Refer to **Figure 6**.

4. Align the exhaust as required. Starting at the front of the exhaust, tighten all clamps and connections.



**Figure 6**

5. Check along the whole length of the exhaust system to ensure that there is adequate clearance around the spare tire, fuel and brake lines or any wiring. If any interference is detected relocate or adjust.



**Congratulations!** You are ready to begin experiencing the improved power, sound and driving experience of your MBRP Inc. performance exhaust system. We hope you enjoy your purchase.