

S7018

**2010 CAMARO 6.2L CAT BACK DUAL
EXHAUST (ROUND TIPS)**

MBRP
INC.

PERFORMANCE EXHAUST

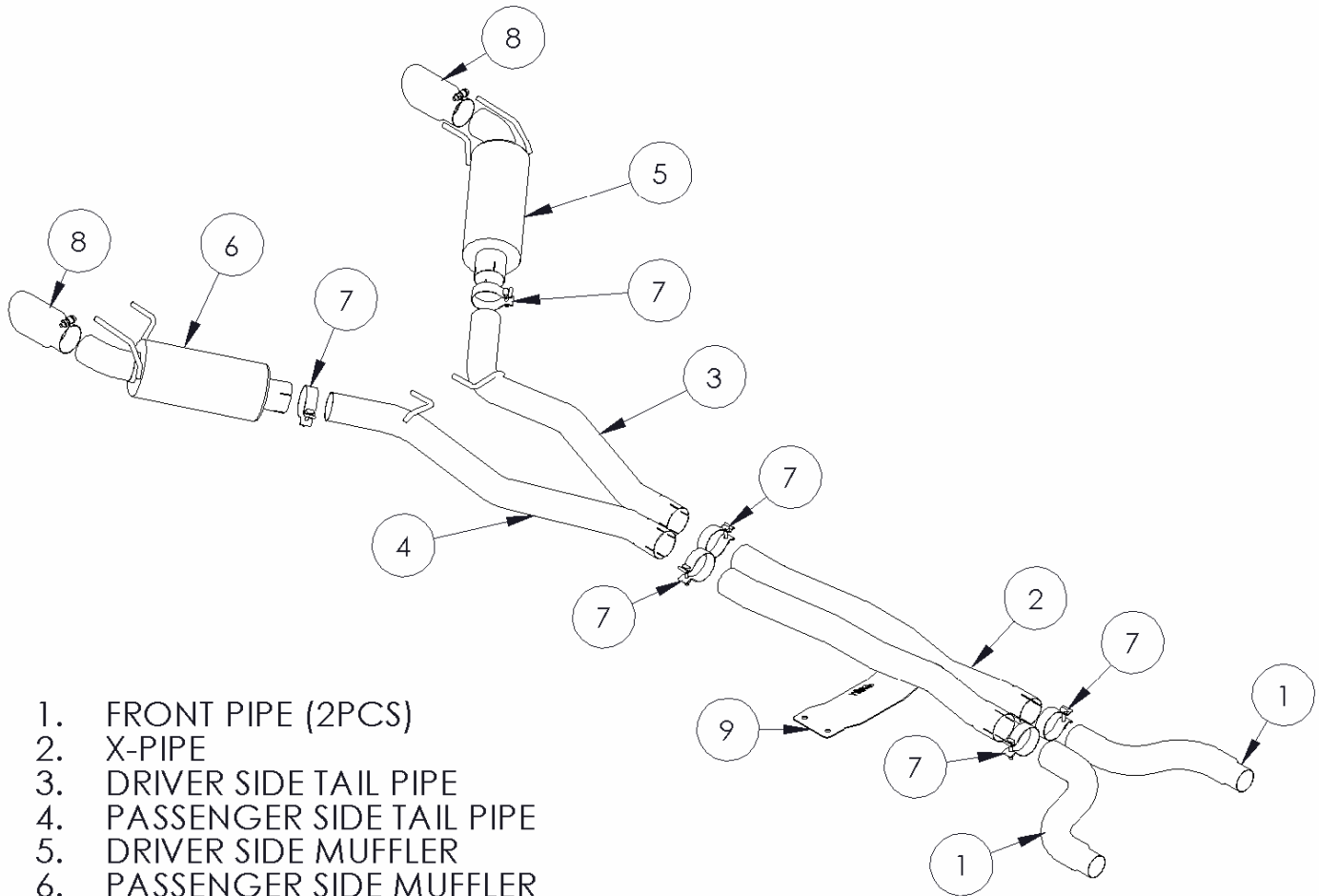

1. FRONT PIPE (2PCS)
2. X-PIPE
3. DRIVER SIDE TAIL PIPE
4. PASSENGER SIDE TAIL PIPE
5. DRIVER SIDE MUFFLER
6. PASSENGER SIDE MUFFLER
7. 3" CLAMP (6 PCS)
8. EXHAUST TIP (2 PCS)
9. CROSS-MEMBER

PLEASE READ BEFORE STARTING INSTALLATION

While MBRP Inc. has made every effort to ensure that all components of this system are of superior quality and properly packaged it is the installer's responsibility to ensure the following before removal of the factory exhaust:

- that ALL components shown above are present.
- that ALL mating components fit together.
- that there are no damaged components.
- that the system you have purchased is appropriate for your vehicle year, model and configuration.
- that the system will not interfere with any modifications previously installed or planned.
- that you have read and understand these instructions.

If you have any questions or are uncertain about any aspect of the installation of this system to your vehicle please contact your dealer before commencing installation.

2010 CHEVROLET CAMARO SS

Removal of Stock System:

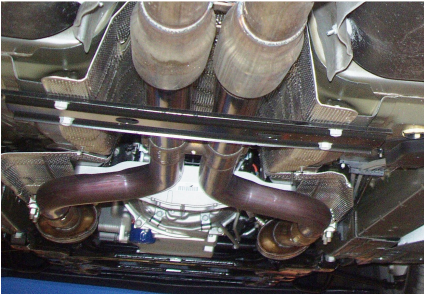

Figure 1



Figure 2



Figure 3



Figure 4

1. Apply a penetrating lubricant liberally to all exhaust fasteners, hangers and rubber insulators.

2. Remove the factory cross-member using a 15mm socket. Retain the fasteners. The cross-member can be returned to the customer.

Refer to Figure 1.

3. Loosen the sleeve clamps on the factory exhaust located behind the catalytic converters using a 15mm socket. Using a screwdriver pry back the tabs on the clamps. **Refer to Figure 1.**

4. The exhaust comes down as one piece from the cat back. We recommend three people remove the stock exhaust, one person at the front the others supporting the muffler to prevent the tips from marking the fascia. With help in place remove the rubber isolators and then slide the entire system rearward to remove it from the sleeve clamps behind the catalytic converters. Once you have lowered the system just below the sleeve clamps you can push the system forward to remove. **Refer to Figure 2 & 3.**

Figure 4 shows the exhaust removed.

Installation of MBRP Inc. Performance Exhaust:



Figure 5

1. Loosely preassembly the **Front Pipes** to the **X-Pipe** with **3" Clamps**. Install to the vehicle using the factory sleeve clamps. The **Front Pipes** should be on an upward slope to the **X-Pipe**, approximately ten degrees. **Refer to Figure 5.**

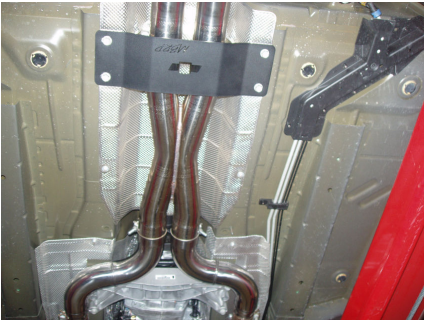

Figure 6

2. Install the **Cross-Member** using the hardware removed earlier. Refer to **Figure 6**.



Figure 7

3. Loosely install the **Passenger Side Tail Pipe** and **Driver Side Tail Pipe** onto the **X-Pipe** using two **3" Clamps**. Attach the factory rubber isolators to the **Tail Pipe** hangers. Refer to **Figure 7**.

4. Carefully install the **Passenger Side Muffler** onto the **Passenger Side Tail Pipe** using a **3" Clamp** and mount it to the factory rubber isolator. Repeat on the driver's side. Refer to **Figure 8**.



Figure 8

5. Install and adjust the **Exhaust Tips**. Before tightening the system check the tips are in the center of the fascia openings. Insert a 1" wood or rubber spacer between the **X-Pipe** and the **Cross-Member** before tightening the system. Check to make sure the **X-Pipe** is level. Starting at the front of the exhaust, tighten all clamps and connections. Refer to **Figure 9**.

6. Check along the whole length of the exhaust system to ensure that there is adequate clearance around the fascia, fuel and brake lines or any wiring. If any interference is detected relocate or adjust.



Figure 9



Congratulations! You are ready to begin experiencing the improved power, sound and driving excitement of your MBRP Inc. performance exhaust system. We know you will enjoy your purchase.