

# S5502

2007-2011 JEEP WRANGLER/RUBICON 4DR  
3.8L V6, CAT BACK, SINGLE REAR EXIT

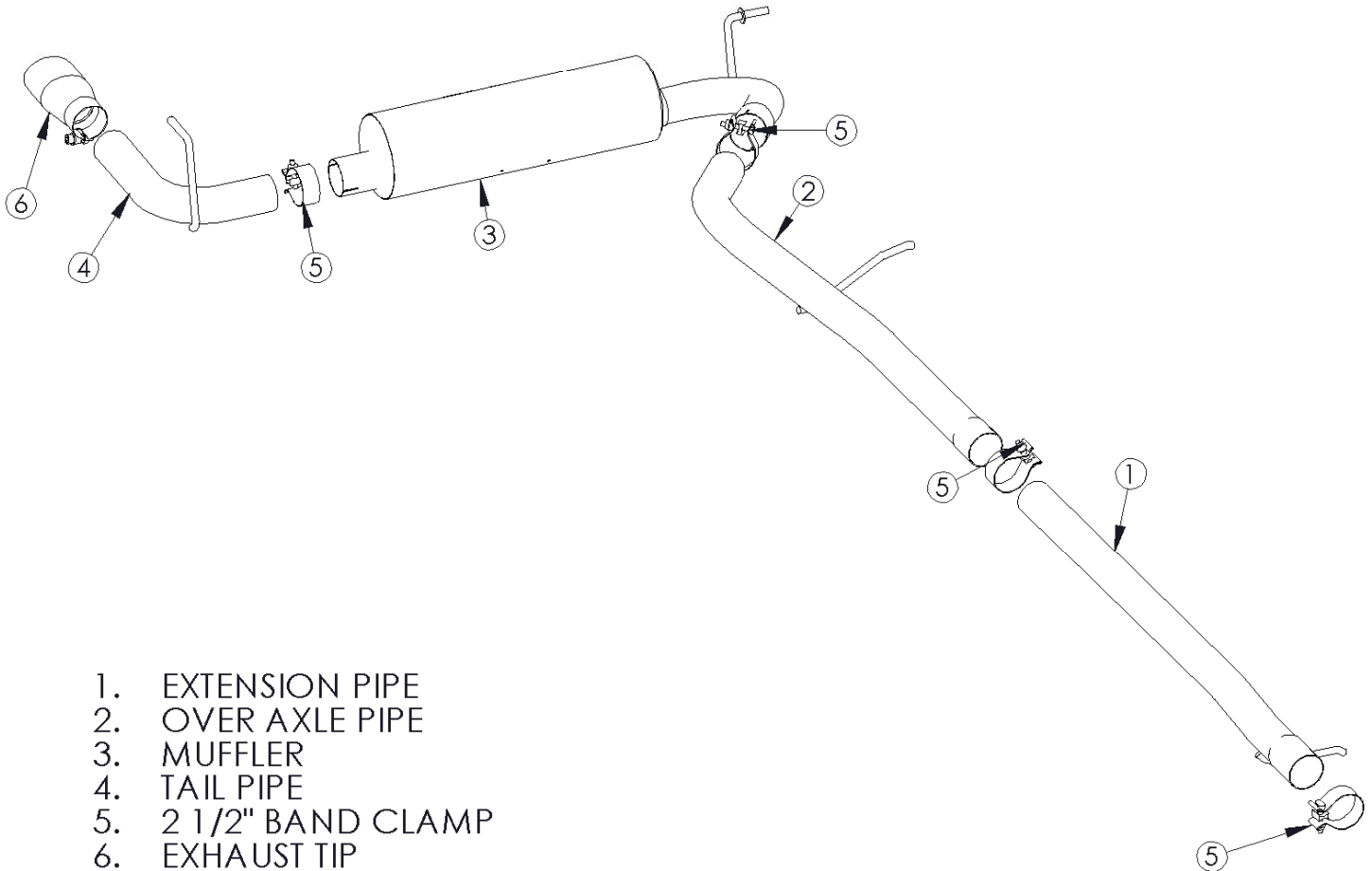

1. EXTENSION PIPE
2. OVER AXLE PIPE
3. MUFFLER
4. TAIL PIPE
5. 2 1/2" BAND CLAMP
6. EXHAUST TIP

NOTE: SADDLE CLAMPS USED IN ALUMINIZED VERSION

## PLEASE READ BEFORE STARTING INSTALLATION

**While MBRP Inc. has made every effort to ensure that all components of this system are of superior quality and properly packaged, it is the installer's responsibility to ensure the following before removal of the factory exhaust:**

- that ALL components shown above are present.
- that ALL mating components fit together.
- that there are no damaged components.
- that the system you have purchased is appropriate for your vehicle year, model and configuration.
- that the system will not interfere with any modifications previously installed or planned.
- that you have read and understand these instructions.

If you have any questions or are uncertain about any aspect of the installation of this system to your vehicle please contact your dealer before commencing installation.

## 2007-2008 JEEP WRANGLER

### Removal of stock system:



**Figure 1**

1. Apply a penetrating lubricant liberally to all exhaust fasteners, hangers and rubber insulators.

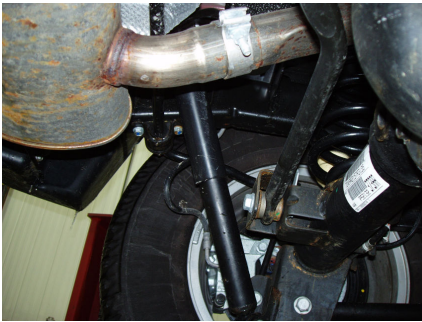

**Figure 2**

2. Loosen the guard below the transfer case and remove. **Refer to Figure 1.**

3. Start to remove the exhaust by loosening the clamp just before the muffler on the driver's side. **Refer to Figure 2.**



**Figure 3**

4. The muffler can be removed by removing the hangers from the rubber isolators, one on each side. **Refer to Figure 3.**



**Figure 4**

5. Loosen the clamp on the extension pipe and remove from the existing isolators. **Refer to Figure 4.**



Figure 5



Figure 6



Figure 7

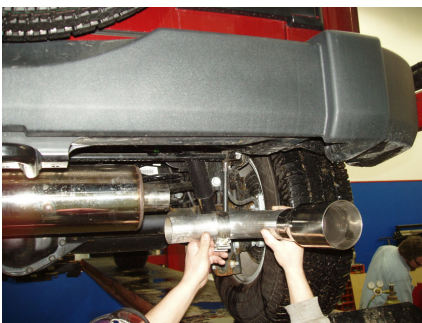

Figure 8



## Installation of MBRP Inc. Performance Exhaust:

1. Install the **Extension Pipe** using a **2 ½” Clamp** and attaching to the existing rubber isolator. Leave the clamp loose enough for some adjustment. **Refer to Figure 5.**
2. Slide a **2 ½” Clamp** over the **Extension Pipe** and install the **Over Axle Pipe** to the **Extension Pipe**. Attach the **Over Axle Pipe** hanger to the existing rubber isolator. **Refer to Figure 6.**
3. Slide a **2 ½” Clamp** onto the **Over Axle Pipe**. Install the **Muffler** to the **Over Axle Pipe**, install the **Muffler** hanger into the factory rubber insulator. **Refer to Figure 7.**
4. Slide a **2 ½” Clamp** over the **Tail Pipe** and install onto the **Muffler**. Slide the **Tail Pipe** hanger into existing the rubber insulator. **Refer to Figure 8.**
5. Install the **Exhaust Tip** onto the **Tail Pipe** and tighten.
6. Align the exhaust as required. Starting at the front of the exhaust, tighten all clamps and connections.
7. Reinstall the guard below the transfer case.
8. Check along the whole length of the exhaust system to ensure that there is adequate clearance around the spare tire, fuel and brake lines or any wiring. If any interference is detected relocate or adjust.

**Congratulations!** You are ready to begin experiencing the improved power, sound and driving experience of your MBRP Inc. performance exhaust system. We hope you enjoy your purchase.