

Please read and save these instructions. Read through this owner's manual carefully before using the product. Protect yourself and others by observing all safety information, warnings and cautions. Failure to comply with these instructions could result in personal injury and/or damage to the product or property. Please retain instructions for future reference.



MANUAL BUSHING INSTALLATION AND REMOVAL TOOL SET

FOR CUSTOMER SERVICE

Technical Question?

CALL 1-866-458-2472

customerservice@oem-tools.com

UNPACKING

After unpacking the unit, inspect carefully for any damage that may have occurred during transit. Check for loose, missing or damaged parts. If any damage is observed, a shipping damage claim must be filed with the carrier. Do not use the Manual Bushing Installation and Removal Tool if broken, bent, cracked or damaged parts (including labels) are noted. Any Manual Bushing Installation and Removal Tool that appears damaged in any way, operates abnormally or is missing parts should be removed from service immediately. If you suspect that the Manual Bushing Installation and Removal Tool was subjected to a shock load (a load that was dropped suddenly, unexpectedly, etc.) immediately discontinue use until it has been checked by a factory authorized service center.

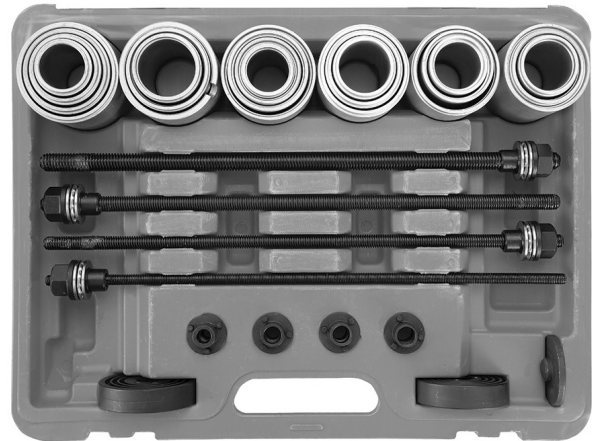

⚠ WARNING

The following safety information is provided as a guideline to help you operate your Manual Bushing Installation and Removal Tool under the safest possible conditions. Any tool or piece of equipment can be potentially dangerous to use when safety or safe handling instructions are not known or not followed. The following safety instructions are to provide the user with the information necessary for safe use and operation. Please read and retain these instructions for the continued safe use of your tool. Failure to follow instructions listed below may result in serious injury. In addition, make certain that anyone who uses the equipment understands and follows these safety instructions as well.

Explanation of Safety Signal Words

⚠ WARNING: Indicates a potentially hazardous situation which, if not avoided, could result in death or serious injury.

⚠ CAUTION: Indicates a potentially hazardous situation which, if not avoided, may result in minor or moderate injury.

CAUTION: Used without the safety alert symbol indicates a potentially hazardous situation which, if not avoided, may result in property damage.

NOTES: Provide clarity and helpful information.

Thank you very much for choosing an OEMTOOLS® Product!

For future reference, please register your new tool at www.oem-tools.com and complete the owner's record below:

Model: _____ **Purchase Date:** _____

Save the receipt, warranty and these instructions. It is important that you read the entire manual to become familiar with this product before you begin using it. This product is designed for certain applications only. OEMTOOLS® cannot be responsible for issues arising from modification. We strongly recommend this product is not modified and/or used for any application other than that for which it was designed. If you have any questions relative to a particular application, DO NOT use the product until you have first contacted customer service to determine if it can or should be performed on the product.



MANUAL BUSHING INSTALLATION AND REMOVAL TOOL SET



IMPORTANT INSTRUCTIONS AND SAFETY RULES

1. Know your tool. Read this manual carefully. Learn the tool's applications and limitations, as well as, potential hazards specific to it.
2. Keep work area clean and well lit. Cluttered or dark work areas invite accidents.
3. Keep children away. All children should be kept away from the work area. Never let a child handle a tool without strict adult supervision.
4. Do not operate this tool if under the influence of alcohol or drugs. Read warning labels on prescriptions to determine if your judgment or reflexes are impaired while taking drugs. If there is any doubt, do not attempt to operate.
5. Use safety equipment. Eye protection should be worn at all times when operating this tool. Use ANSI approved safety glasses. Everyday eyeglasses are NOT safety glasses. Dust mask, non-skid safety shoes, hard hat or hearing protection should be used in appropriate conditions.
6. Wear proper apparel. Loose clothing, gloves, neck-ties, rings, bracelets or other jewelry may present a potential hazard when operating this tool. Keep all apparel clear of the tool.
7. Don't overreach. Keep proper footing and balance at all times when operating this tool.
8. Check for damage. Check your tool regularly. If part of the tool is damaged it should be carefully inspected to make sure that it can perform its intended function correctly. If in doubt, the part should be repaired. Refer all servicing to a qualified technician. Consult your dealer for advice.
9. Keep away from flammables. Do not attempt to operate this tool near flammable materials or combustibles. Failure to comply may cause serious injury or death.
10. Store idle tools out of the reach of children and untrained persons. Tools may be dangerous in the hands of untrained users.
11. Maintain tools with care.
12. Keep tools dry and clean.
13. Properly maintained tools are less likely to bind and are easier to control. Do not use a damaged tool. Tag damaged tools "Do not use" until repaired.
14. Check for misalignment or binding of moving parts, breakage of parts, and any other condition that may affect the tool's operation.
15. If damaged, have the tool serviced before using. Many accidents are caused by poorly maintained tools.
16. Use only accessories that are recommended by the manufacturer for your model. Accessories that may be suitable for one tool may become hazardous when used on another tool.
17. Tool service must be performed only by qualified repair personnel. Service or maintenance performed by unqualified personnel could result in a risk of injury.
18. When servicing a tool, use only identical replacement parts. Use of unauthorized parts or failure to follow maintenance instructions may create a risk of injury.
19. Maintain a safe working environment. Keep the work area well lit. Make sure there is adequate surrounding workspace. Keep the work area free of obstructions, grease, oil, trash, and other debris. Do not use this product in a damp or wet location.
20. Maintain labels and nameplates on this product. These carry important information. If unreadable or missing, contact OEMTOOLS® for a replacement.
21. Before use, read and understand all warnings, safety precautions, and instructions as outlined in the vehicle manufacturer's service manual. It is beyond the scope of this manual to properly describe the correct procedure and test data for each vehicle.
22. Always perform vehicle service in a properly ventilated area. Never run an engine without proper ventilation for its exhaust. Stop work and take necessary steps to improve ventilation in the work area if you develop momentary eye, nose, or throat irritation as this indicates inadequate ventilation.
23. Engine parts that are in motion and unexpected movement of a vehicle can injure or kill. When working near moving engine parts, wear snug fit clothing and keep hands and fingers away from moving parts. Keep hoses and tools clear of moving parts. Always stay clear of moving engine parts. Hoses and tools can be thrown through the air if not kept clear of moving engine parts.
24. The unexpected movement of a vehicle can injure or kill. When working on vehicles always set the parking brake or block the wheels.
25. Avoid accidental fire and/or explosion. Do not smoke near engine fuel and battery components.
26. The warnings, precautions, and instructions discussed in this manual cannot cover all possible conditions and situations that may occur. The operator must understand that common sense and caution are factors which cannot be built into this product, but must be supplied by the operator.
27. For safety purposes and the prevention of damage to expensive components it is advised that the user have an understanding of basic automotive repair and a working knowledge of automotive systems.
28. We believe the information contained herein to be reliable. However, general technical information is given by us without charge and the user shall employ such information at their own discretion and risk. We assume no responsibility for results or damages incurred from the use of such information in whole or in part. Always refer to specific instructions and technical information supplied by vehicle manufacturer.
29. The manufacturer declines any and all responsibility for damage to vehicles or components if said damage is the result of unskillful handling by the operator or of failure to observe the basic safety rules set forth in the instruction manual.
30. This equipment is intended only for professional use by personnel trained in performing the service functions for which it is has been designed.
31. This equipment is designed for servicing a variety of vehicles in a safe, convenient manner. However, differences in vehicle makes and models may make it impossible to use this equipment as it is intended. Do not attempt to force the use of this equipment on an application for which it is not designed to perform.
32. The procedures documented in this manual are to serve as guidelines for the use of this equipment.
33. In addition to these guidelines, always follow the manufacturer's recommended procedures when servicing each unique vehicle.
34. The use of this equipment is simple and straightforward if you follow the instructions. When operating this equipment, use common sense, and always stop to think before using this tool.

WARNING

1. Always keep forcing screw well lubricated. Use a high-quality, anti-seize compound.
2. **DO NOT** use air tools.
3. **DO NOT** exceed the maximum recommended torque for each forcing screw.
NOTE: Exceeding these torque values may shorten the life of the forcing screws. The forcing screws are considered to be consumable items and are **NOT** covered under warranty.

PURPOSE

The OEMTOOLS® Manual Bushing Installation and Removal Tool Set is a comprehensive set used for fast and effective removal/installation of wheel bearings/suspension bushings and seals. It reduces the possibility of damaging the bearing/suspension housings. It includes (2) stepped end plates and (4) forcing screws in a blow mold case. The plates and sleeves can also be used in a standard workshop press when access isn't possible.



MANUAL BUSHING INSTALLATION AND REMOVAL TOOL SET

OPERATION

BUSHING/BEARING REMOVAL (Fig. 5)

NOTE: Before starting, mark the place where the existing bushing is installed to ensure accurate positioning of the replacement bushing.

1. Select a sleeve that will sit square on the bushing/bearing housing and will allow the bushing/bearing to be extracted without interference. Ensure that only the force end of the sleeve with the U-shape inspection slot is used to sit on the bushing/bearing housing. The stepped end of the sleeve should be used to locate in the end plate.
2. Select a second sleeve that will sit square on the outer ring of the bushing/bearing and will pass through the bushing/bearing housing without interference. Ensure that only the force end of the sleeve with the U-shape inspection slot is used to sit on the outer ring of the bushing/bearing. The stepped end of the sleeve should be used to locate in the end plate.
3. Remove the nuts and thrust washers and pass the forcing screw halfway through the bushing/bearing center hole.

NOTE: Lubricate the forcing screw before use.

NOTE: Always use the largest diameter forcing screw available that will fit through the center of the bushing/bearing.

4. Fit the end plates to the stepped ends of the selected sleeves. Ensure that side-A is only used for 'A' sleeves and side-B is only used for 'B' sleeves.
5. Slide the assembled end plates and sleeves over the forcing screw and install the thrust washers and nuts.
6. Progressively tighten the nuts while locating the sleeves squarely on the bushing/bearing housing and the bushing/bearing outer ring.
7. Once the sleeves are square on the housing and outer ring, tighten the nuts and check that the thrust washers are centered in the end plates.
8. Using the appropriate sized wrenches hold the forcing nut that has the 3 pins and gradually tighten the forcing nut that has the bearing, driving bushing/bearing from the housing.

⚠ WARNING

DO NOT use air tools to operate the force screw nuts.

DO NOT exceed the maximum recommended torque for each forcing screw.

BUSHING/BEARING INSTALLATION (FIG. 5)

1. Select the appropriate size sleeves for the housing and bushing/bearing as described in the removal section.
2. Prior to installing the bushing/bearing, clean the inside of the housing with an abrasive cloth to ensure that it is free of debris and corrosion.
3. Lightly oil the outer ring of the bushing/bearing to be installed.
4. You may use a hammer to gently tap around the outer ring of the bushing/bearing to locate it into the housing.

NOTE: Make sure that the bushing/bearing is square to the housing when installing.

NOTE: Always use the largest diameter forcing screw available that will fit through the center of the bushing/bearing.
5. Lubricate the forcing screw and assemble the kit as described in the removal section and shown in Fig. 5.
6. Once the sleeves are square on the housing and outer ring, tighten the nuts and check that the thrust washers are centered in the end plates.
7. Using the appropriate sized wrenches hold the forcing nut that has the 3 pins and gradually tighten the forcing nut that has the bearing, driving bushing/bearing into the housing. Ensure that the bushing/bearing is square to the housing during installation.

USING WITH A WORKSHOP PRESS

1. Where access is not possible, the end plates and sleeves can be used with a standard workshop press for bushing/bearing removal and installation.
2. To avoid damage to the end plates, use the provided shop press plate between the press and the end plate during workshop press operation.

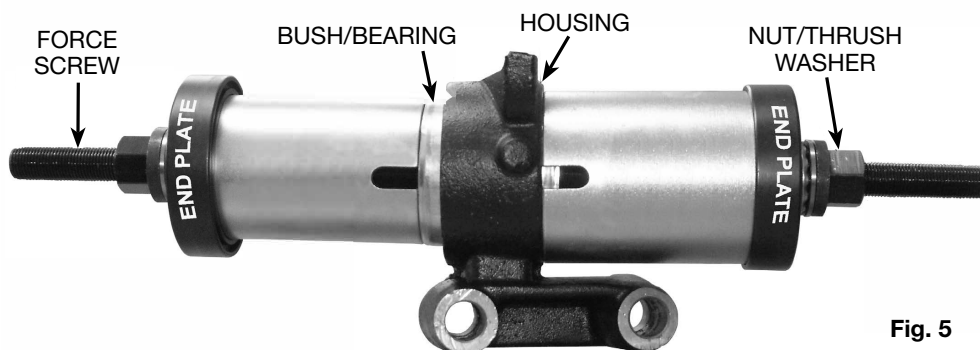

Fig. 5



MANUAL BUSHING INSTALLATION AND REMOVAL TOOL SET

Sleeve 'A' (11 pieces)

Item #	Sizes
A	D44 x d34
B	D46 x d36
C	D54 x d44
D	D56 x d46
E	D58 x d48
F	D66 x d56
G	D68 x d58
H	D70 x d60
I	D78 x d68
J	D80 x d70
K	D82 x d72

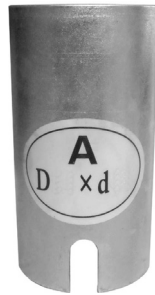

Sleeve 'B' (9 pieces)

Item #	Sizes
A	D48 x d38
B	D50 x d40
C	D52 x d42
D	D60 x d50
E	D62 x d52
F	D64 x d54
G	D72 x d62
H	D74 x d64
I	D76 x d66



Forcing Screws With Nuts and Thrust Washers

Item	Sizes	Max Torque
A	M10X1.5	33Nm (24 Ft/Lbs.)
B	M12X1.5	60Nm (44 Ft/Lbs.)
C	M14X1.5	99Nm (73 Ft/Lbs.)
D	M16X1.5	155Nm (114 Ft/Lbs.)



Shop Press Plate

Note: Not all components of the Manual Bushing Installation and Removal Tool are replacement items, but are illustrated as a convenient reference for location and position in the assembly sequence.

The manufacturer and/or distributor have provided the parts list and assembly diagram in this manual as a reference tool only. Neither the manufacturer nor distributor makes any representation or warranty of any kind to the buyer that

he or she is qualified to make any repairs to the product, or that he or she is qualified to replace any parts of the product. In fact, the manufacturer and/or distributor expressly states that all repairs and parts replacements should be undertaken by certified and licensed technicians, and not by the buyer. The buyer assumes all risk and liability arising out of his or her repairs to the original product or replacement parts thereto, or arising out of his or her installation of replacement parts thereto.

OEMTOOLS® LIMITED LIFETIME WARRANTY

Please read the following carefully.

If for as long as you own this OEMTOOLS® product you find any defect in material or workmanship, through normal usage, return it to the place of purchase, or to OEMTOOLS® for repair or replacement at our discretion. In order to obtain this service send your tool and proof of purchase, transportation pre-paid, to OEMTOOLS® Q.A. Dept, 3850 Raines Road #3, Memphis, TN 38118. We will not be responsible for lost or damaged goods during transportation, please insure your package. If our inspection verifies the defect, we will either repair or replace the product at our election, or we may elect to refund the purchase price if we cannot readily and quickly provide you with a replacement. We will return repaired products at our expense, but if we determine there is no defect, or that the defect resulted from causes not within the scope of our warranty, then you must bear the cost of returning the product.

OEMTOOLS® does not provide warranty for products labeled other than OEM® or OEMTOOLS®. OEMTOOLS® will not provide any warranty for products subjected to abnormal use. Abnormal use includes, but is not limited to, abuse, accident, alteration, neglect, and unauthorized or unreasonable use or repairs. This warranty does not cover bits, blades, files, batteries, or calibration. We recommend that you maintain your tools and sharpen or replace blades, bits, files, and batteries as necessary. OEMTOOLS® reserves the right to make any changes in construction or design at any time without any obligation in incorporating such changes to tools or equipment previously sold.

OEMTOOLS® makes every effort to assure that its products meet high quality and durability standards, and warrants to the original purchaser that this product is free from defects in materials and workmanship for the duration of this warranty from the date of purchase. This warranty does not apply to damage due directly or indirectly to misuse, abuse, negligence or accidents, repairs or alterations outside our facilities, criminal activity, improper installation, normal wear and tear or to lack of maintenance.

We shall in no event be liable for death, injuries to persons or property, or for incidental, contingent, special or consequential damages arising from the use of our product. Some states do not allow the exclusion or limitation of incidental or consequential damages, so the above limitation of exclusion may not apply to you.

THIS WARRANTY IS EXPRESSLY IN LIEU OF ALL OTHER WARRANTIES, EXPRESS OR IMPLIED, INCLUDING THE WARRANTIES OF MERCHANTABILITY AND FITNESS.

This warranty gives you specific legal rights, and you may also have other rights, which vary from state to state.

Don't forget to register your new OEMTOOLS® product at www.oem-tools.com.

CONTACT US

3580 E. Raines Road, Suite 3, Memphis, TN 38118
 Tel: 1-866-458-2472
www.oem-tools.com