



Vacuum Pump P/N 22642

IMPORTANT: USE THE FITTINGS SUPPLIED WITH THIS VACUUM PUMP. THE USE OF ANY OTHER BRAND OF FITTINGS WILL DAMAGE THIS UNIT!

This Vacuum Pump is designed for racing engines requiring a supplementary vacuum (evacuation) source. The Moroso P/N 22642 Vacuum Pump has proven to be a more efficient unit in design, function and ease of maintenance than previous designs from all manufacturers. This unit performs from engine idle, throughout the entire RPM range.

Moroso recommends as a starting point running this vacuum pump at 50% engine RPM. Adjustments can be made to gain or reduce the amount of vacuum you are achieving based on drive ratio or Vacuum Relief Valve.

As always, you can only achieve desired results with a properly sealed engine. If poor vacuum results are already present with your motor, for example leaks in various areas or poor ring seal, may be the cause and would need to be addressed before ANY Vacuum Pump can work properly. Also, on that note, a new Vacuum Pump may also find potential leaks with your engine by pulling a great amount of vacuum through the engine, causing the weak spot to become a leak and causing the pump to show poor results.

NOTE: The Inlet and Outlet of the Pump is determined by the direction of pump rotation. If the pump is rotating in a clockwise direction, the first fitting in that direction is the outlet and the second is the inlet. The exact opposite is true if the pump rotates counterclockwise, (see diagram).

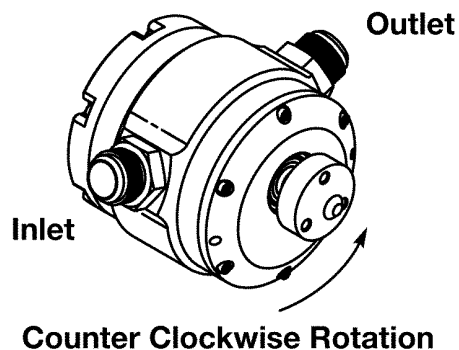
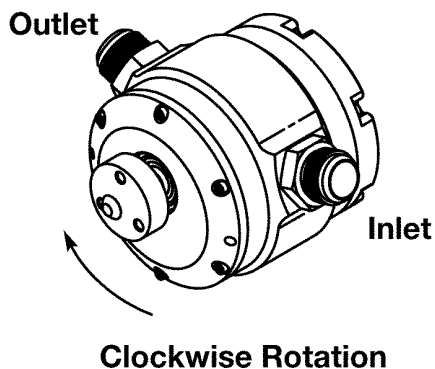

**For Technical Assistance, Call Moroso's Tech Line at
(203) 458-0542, 8:30am – 5:00pm Eastern Time**

MOROSO PERFORMANCE PRODUCTS, INC
80 CARTER DR • GUILFORD, CT 06437-2116
Phone: (203) 453-6571 • Fax: (203) 453-6906

INSTALLATION

Determine a location for mounting the Vacuum Pump assembly. The supplied Mounting Bracket will fit on the front or back of the Vacuum Pump to allow for space requirements. This Bracket will allow the Vacuum Pump to be mounted on any Motor Plate, Small Block and Big Block Chevrolet cylinder heads and various locations on these motors.

Install the rubber O-rings onto the supplied AN Fittings and screw the Fittings into the Pump housing. Make sure O-ring is seated correctly between pump housing and fitting before tightening.

IMPORTANT: The Fittings supplied are specially made for Moroso Vacuum Pumps. DO NOT use any other type of fittings, if you need a replacement fitting contact a Moroso Dealer for p/n 97641.

Determine the Inlet from the instructions above and plumb a hose to the valve cover using a -12AN fitting. DO NOT use a catch can between this hose to the valve cover.

Plumb the Outlet side of the Pump to a Breather Tank, such as Moroso p/n 85465. A Breather Tank is necessary to catch any oil residue that is pulled from the engine during operation.

Determine the speed the Vacuum Pump will be running. Moroso recommends starting at 50% of your engine speed. Select and install a Drive Pulley to the mounting Hub of the Pump and secure with the supplied hardware. Tighten the bolts in a cross pattern to 16 ft.-lbs. Moroso offers many styles and sizes of Pulleys, check a Moroso Catalog or consult a Moroso dealer.

Install the correct length drive belt and tighten properly. **DO NOT over-tighten the belt**, doing so will cause excessive side load on the pump bearings. Check that all bolts are tight and that the pulley and drive belt on the Vacuum Pump are aligned with the pulley on the crankshaft.

The vane material used in this Vacuum Pump requires an initial break-in to seat the vanes to the pump housing for maximum vacuum. During this time you may notice a black dust or residue exiting the pump outlet. This is normal. As the vanes mate to the housing bore this condition will stop.

MAINTENANCE

We recommend that your Vacuum Pump be cleaned on a regular basis for optimum performance. When performing any maintenance, wear approved safety glasses.

Loosen the Vacuum Pump Pulley bolts and remove the Pulley. Remove Vacuum Pump from engine and remove Bearing Cap from the back of the Pump.

Remove the Rear Cover from the Pump Housing, remove the Vanes from the Rotor slots noting the notches on the bottom and top of the Vanes face towards the shaft and the worn in edge of the Vane curves to match the shape of the Rotor. Remove the Front Cover and Rotor Shaft assembly. Disassemble Rotor from shaft.

Clean all pieces, (Vanes, Housing, Rotor & Shaft, Front & Rear Covers, Bearing Cap), using a mild part cleaning solvent or soap and water. Inspect parts for wear or damage. If rebuilding is necessary use Rebuild Kit p/n 97642 or contact Moroso Performance Technical Service Department at (203) 458-0542 for information on how we can service your pump for you.

When all pieces are cleaned and ready for assembly, place the Rotor Shaft Keys onto the Shaft. Install Rotor onto Shaft being careful to keep the Shaft Keys in place.

Next, place the Rotor, Shaft and Front Cover assembly into the Housing. Replace the Vanes making sure the Vane notches are facing the Shaft and the curved "worn-in" ends are facing the Housing. If you are using new Vanes, they will not have a curved end, follow the instructions provided with the rebuild kit.

Replace Rear Cover and Bearing Cap. Install and tighten Front and Rear Cover hardware and Bearing Cap Screw. Re-install Pump onto your engine.