



## **Vacuum Pump Rebuild Kit P/N's 22645, 22646**

4 - Thrust Washers	2 - Thrust Bearings
2 - Flat Head Set Screws	1 - Viton Shaft Seal
2 - Socket Head Set Screws	3 - Vanes (w/kit P/N 22645)
2 - Shaft Bearings	4 - Vanes (w/kit P/N 22646)

*This kit is designed to replace the bearings and vanes in a Moroso Vacuum Pump. The vacuum pump should be rebuilt at least once a year to ensure top performance.*

### **INSTRUCTIONS**

1. Remove the pump from the engine and take off the pump pulley.
2. Loosen and remove the four socket head retaining bolts on the lid and slide the lid/shaft assembly out of the housing and set aside.
3. Remove the AN fittings from the housing body.
4. Loosen and remove the two 10-32 rotor set screws from the shaft assembly. (Take note of the type of set screws that were just removed, as this kit contains two different styles of replacement set screws). Slide the rotor and lid off of the shaft.
5. Remove all vanes, noting where the notched end is facing, (see diagram). Press the seal and shaft bearing out of the lid. Remove the shaft bearing from the housing using a pilot bearing puller tool. Discard all bearings, vanes and seal.
6. Inspect all components and clean with brake cleaner or carb/choke cleaner.
7. Lubricate the shaft bearings with high temperature wheel bearing grease.
8. Press one shaft bearing into the housing bore making sure that the part number on the bearing is facing up. Press the bearing so that it is below the shoulder in the housing bottom.
9. Press the other shaft bearing into the lid bore from the backside of the lid. Make sure the end of the bearing is flush with the machined shoulder.
10. Flip the lid over and press the shaft seal into the lid top with the closed side of the seal facing out. Slide the lid assembly onto the shaft.
11. Lubricate two thrust washers and one thrust bearing with motor oil, sandwich the bearing with the thrust washers and install onto the shaft assembly.
12. Slide the rotor onto the shaft and lock it in place with two of the supplied 10-32 rotor set screws that match your application. (These set screws should match the type that were removed in step #4). Use Loctite® #263 or equivalent on the screws and torque to 60 in.-lbs.

13. Lubricate two thrust washers and one thrust bearing with motor oil, sandwich the bearing with the thrust washers and install onto the shaft assembly.
14. Install the supplied vanes, (3 vanes with kit p/n 22645, or 4 vanes with kit p/n 22646), into the rotor slots with the notched and chamfered ends of the vanes facing in. (See diagram).
15. Install the housing body over the lid/shaft assembly aligning the housing with the dowel pins. Secure the assembly with the four socket head retaining bolts and torque to 192 in.-lbs.
16. Reinstall the AN fittings and mount the pump on the engine. Do not over tighten the drive belt. Belt flex should not have less than 1" deflection over a 12" span.

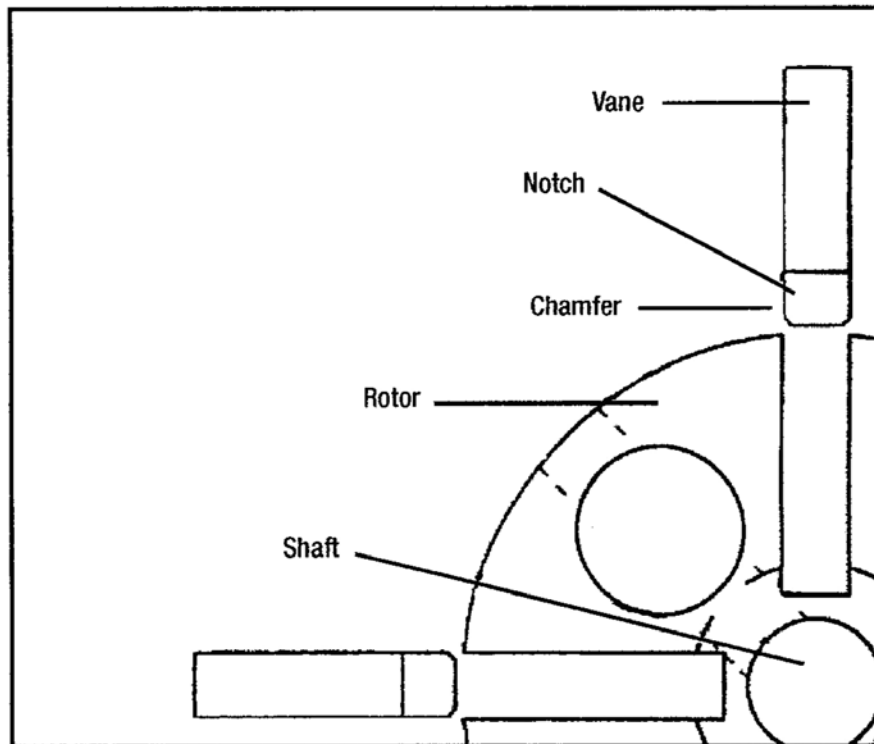

**For Technical Assistance, Call Moroso's Tech Line at  
(203) 458-0542, 8:30am – 5:00pm Eastern Time**

MOROSO PERFORMANCE PRODUCTS, INC  
80 CARTER DR • GUILFORD, CT 06437-2116  
Phone: (203) 453-6571 • Fax: (203) 453-6906