



## Turbo 350 Transmission Pan P/N 42010

### PARTS LIST

- |                        |                            |
|------------------------|----------------------------|
| 1 Transmission Pan     | 2 Hex Bolts 1/4 -20 x 1.5" |
| 2 Magnetic Drain Plugs | 2 Washers 1/4"             |
| 1 Filter Spacer        | 13 Mounting Studs          |
| 2 Spacer Gaskets       | 13 Serrated Nuts           |

1. Drain fluid from transmission and remove old pan.
2. Clean any old gasket material from the pan-mounting surface.
3. Remove filter, clean thoroughly or replace with a new one. Re-install the filter with the supplied Filter Spacer, Gaskets and Mounting Hardware, (see diagram below). Place a Gasket between the Filter and the Filter Spacer and place the other Gasket between the Filter Spacer and the mounting area. Tighten with the two 1/4 -20 x 1.5" Hex Bolts and 1/4" Washers to 10 ft.-lbs.
4. Install the 13 Mounting Studs into the transmission, place a new gasket on the pan rail, tighten the pan with the Serrated Nuts to 10 ft.-lbs. (NOTE: Moroso Performance does not recommend using any type of sealer on the gasket. Small pieces may dislodge and clog the transmission or transbrake internals resulting in failure). Check that all the Drain Plugs are tight.
5. The Moroso Transmission Pan holds more fluid than a stock shallow sump type pan, so be certain to fill your transmission to the proper level as indicated on the dipstick.

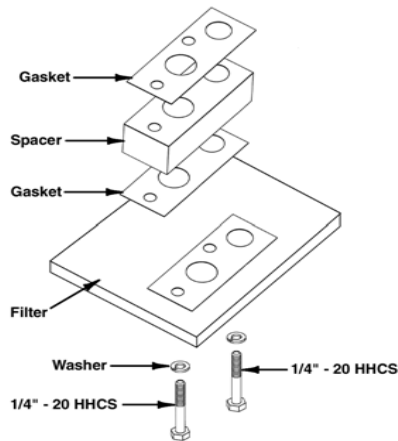

*For Technical Assistance, Call Moroso's Tech Line at  
(203) 458-0542, 8:30am – 5:00pm Eastern Time*

**MOROSO PERFORMANCE PRODUCTS, INC**  
80 CARTER DR • GUILFORD, CT 06437  
Phone: (203) 453-6571 • FAX (203) 453-6906

Visit Us At [www.moroso.com](http://www.moroso.com)



## Turbo 350 Transmission Pan P/N 42010

### PARTS LIST

- |                        |                            |
|------------------------|----------------------------|
| 1 Transmission Pan     | 2 Hex Bolts 1/4 -20 x 1.5" |
| 2 Magnetic Drain Plugs | 2 Washers 1/4"             |
| 1 Filter Spacer        | 13 Mounting Studs          |
| 2 Spacer Gaskets       | 13 Serrated Nuts           |

1. Drain fluid from transmission and remove old pan.
2. Clean any old gasket material from the pan-mounting surface.
3. Remove filter, clean thoroughly or replace with a new one. Re-install the filter with the supplied Filter Spacer, Gaskets and Mounting Hardware, (see diagram below). Place a Gasket between the Filter and the Filter Spacer and place the other Gasket between the Filter Spacer and the mounting area. Tighten with the two 1/4 -20 x 1.5" Hex Bolts and 1/4" Washers to 10 ft.-lbs.
4. Install the 13 Mounting Studs into the transmission, place a new gasket on the pan rail, tighten the pan with the Serrated Nuts to 10 ft.-lbs. (NOTE: Moroso Performance does not recommend using any type of sealer on the gasket. Small pieces may dislodge and clog the transmission or transbrake internals resulting in failure). Check that all the Drain Plugs are tight.
5. The Moroso Transmission Pan holds more fluid than a stock shallow sump type pan, so be certain to fill your transmission to the proper level as indicated on the dipstick.

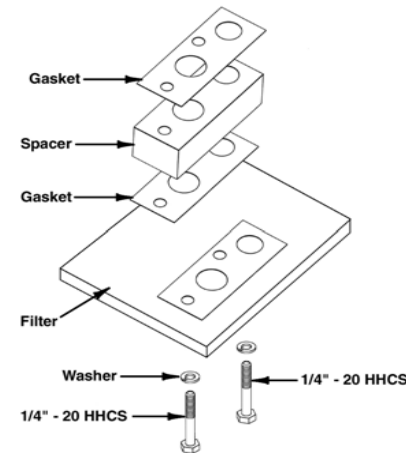

*For Technical Assistance, Call Moroso's Tech Line at  
(203) 458-0542, 8:30am – 5:00pm Eastern Time*

**MOROSO PERFORMANCE PRODUCTS, INC**  
80 CARTER DR • GUILFORD, CT 06437  
Phone: (203) 453-6571 • FAX (203) 453-6906

Visit Us At [www.moroso.com](http://www.moroso.com)