



INSTALLATION INSTRUCTIONS

P/N 63650, 63651, 63655 and 63656

1. Find a suitable location in the engine compartment to mount the tank. When considering the location, at least the upper half of the tank should be above the manifold filler neck or the highest water passage of the cooling system.
2. Once the tank is mounted, proper hose routing is performed (See figure #1.) The bottom of the tank contains a 1/2" fitting. This is connected to the inlet fitting on the water pump. On the upper portion of the tank there is a 1/4" fitting which is connected to the small side fitting on the radiator. If the radiator does not have such a fitting, one will have to be added. CAUTION: DO NOT USE THE OVERFLOW NIPPLE ON THE RADIATOR. This nipple will not work with the expansion system. The expansion tank's nipple is routed to a suitable discharge container. All threaded connections should be sealed with Teflon tape.
3. Fill the system and check for leaks. Install a proper radiator cap and road test.

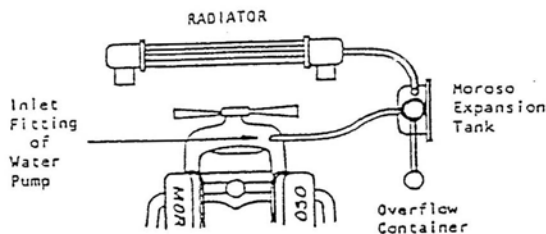
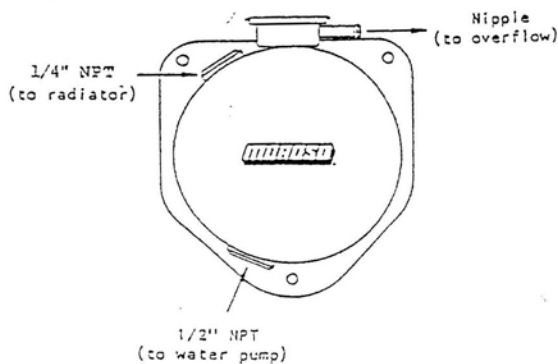
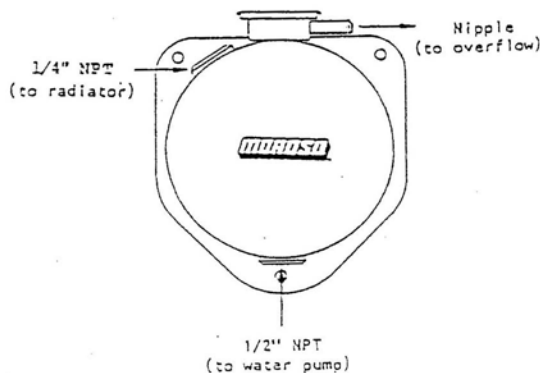

Figure 1



P/N 63655



P/N 63650

**For Technical Assistance, Call Moroso's Tech Line at
(203) 458-0542, 8:30am – 5:00pm Eastern Time**

MOROSO PERFORMANCE PRODUCTS, INC
80 CARTER DR • GUILFORD, CT 06437-2116
Phone: (203) 453-6571 • Fax: (203) 453-6906