

INSTRUCTION SHEET

100A Racing Alternator Snug Mount Bracket BB Chevy 882, 1882, 2882, 8-882, 8-8828

We want to help! If you have any comments or difficulty with this product, please contact technical support at



1833 Downs Drive
West Chicago, IL 60185
(800) 862-7223

e-mail: tech@powermastermotorsports.com

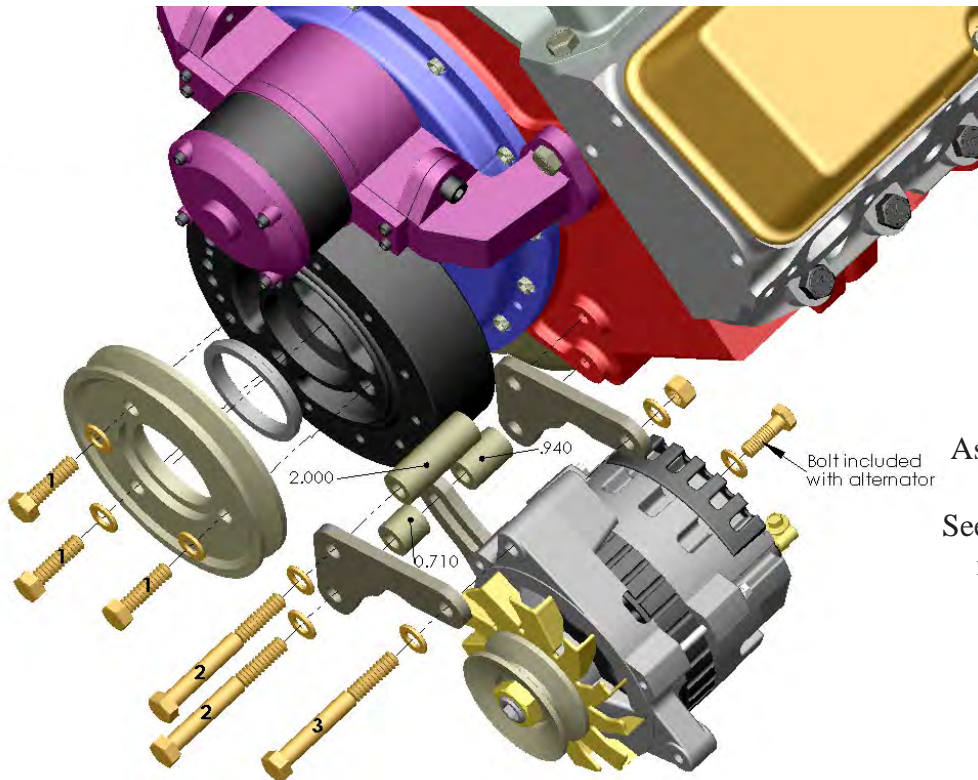
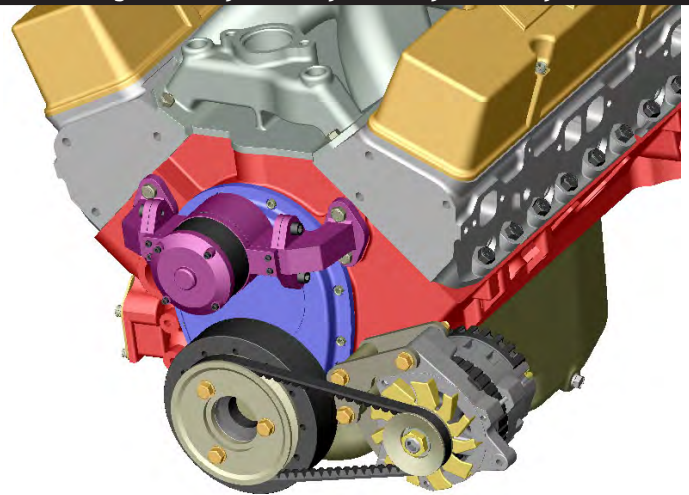

Assembly per illustration.

See reverse side for special notes and instructions

Diagram Ref. #	Part Description	P/N 882 Qty.	P/N 1882 Qty.	P/N 2882 Qty.	P/N 8-882 Qty.	P/N 8-8828 Qty.
	882 triangle bracket	2	2	2	2	2
	882 slotted bracket	1	1	1	1	1
1	3/8"-24 X 1 1/4" bolt				3	3
2	7/16"-14 X 3 1/2" bolt	2	2	2	2	2
3	3/8"-16 X 3 1/2" bolt	1	1	1	1	1
	7/16" flat washer	2	2	2	2	2
	3/8" flat washer	2	2	2	5	5
	5/16" flat washer	1	1	1	1	1
	3/8"-16 nut	1	1	1	1	1
	29/64" ID X 7/8" OD X 2.00" spacer	1	1	1	1	1
	29/64" ID X 7/8" OD X 0.94" spacer	1	1	1	1	1
	29/64" ID X 7/8" OD X 0.71" spacer	1	1	1	1	1
	5.25" V-belt crank pulley				1	1
	Pulley locating bushing, BB				1	1
	2.8" V-belt alternator pulley				1	1
	31 1/4" V-belt (Gates 7312)				1	1
	8072 one wire racing alternator				1	
	8078 XSVolt one wire racing alternator					1

Special Notes:

* This system can be used with electric or short mechanical water pumps. The Pro Series kits include a belt for use with an electric water pump.

* This bracket can be used with most manufacturer's crank and water pump pulleys as long as proper belt alignment is maintained.

* **One wire** alternators require only the charge wire connection to function. An adequate charge wire should be run between the alternator and the positive battery post or the positive battery side of the safety cut off switch. If the alternator's charge wire is connected to the starter's battery connection or on any other positive point on the car that is on the switched side of the cutoff, the car may continue to run after the cutoff switch is opened.

* Be certain that any paint or corrosion is removed from the points where the bracket attaches to the engine block. Also be certain that an adequate ground path is supplied from the engine block to the negative battery post.

* Tension the belt to have 1/2" of deflection.

* If you are installing an 8-8828 Pro Series kit refer to the **XSvolt** alternator instruction sheets for special instructions.

* This bracket can be assembled and mounted on either side of the crank pulley.

Crank pulley installation (included in Pro Series kits)

If installing on an OE balancer:

- Insert the locating bushing into the center notched side of the pulley with the bushing's raised ring facing out.
- Place the spacer on the crank balancer with the bushing side facing the balancer. The bushing's raised ring should locate into the center opening on the balancer.

If installing on a SFI balancer:

- Place the pulley on the balancer with the center notched side facing the balancer. The spacer should locate on the step around the outside circumference of the balancer.
- * Make certain the side of the pulley with the right angle step is toward the motor and the tapered side is facing away from the motor.