



SPX Corporation
 655 Eisenhower Drive
 Owatonna, MN 55060-0995 USA
 Phone: (507) 455-7000
 Tech. Serv.: (800) 533-6127
 Fax: (800) 955-8329
 Order Entry: (800) 533-6127
 Fax: (800) 283-8665
 International Sales: (507) 455-7290
 Fax: (507) 455-7063

Assembly Instructions

for:

927
 938
 939

Push-Puller

The Push-Puller is designed to quickly remove or install gears, bearings, pulleys, couplings, sprockets, shafts, and other press-fitted parts without damage to the part. A variety of adapters, attachments, and legs may be used with the push-puller to apply either pushing or pulling force.

Assembly

- Consider how the tool will be used, and determine whether the forcing screw will be pushing or pulling.
 - If the forcing screw will be pushing** (removing a gear from a shaft):
 - Insert the forcing screw into the cross block with the forcing nut and washer assembled **below** the cross block. See Figure 1.
 - Slide a leg assembly into each end of the cross block with the sliding plates and nuts assembled **above** the cross block and the washers assembled **below** the cross block. See Figure 1.
 - If the forcing screw will be pulling** (removing a shaft from a housing):
 - Insert the forcing screw into the cross block with the forcing nut and washer assembled **above** the cross block. See Figure 2.
 - Slide a leg assembly into each end of the cross block with the nuts and washers assembled **above** the cross block and the sliding plates assembled **below** the cross block. See Figure 2.

Caution: To help prevent personal injury caused by tool failure, the sliding plates **MUST** be assembled on the opposite side of the cross block from the forcing nut.

- Regularly clean and lubricate the forcing screw to ensure the correct operation of the tool.

Safety Precautions

- Caution:** To help avoid personal injury or equipment damage,
- Wear eye protection that meets the requirements of ANSI Z87.1 and OSHA.
 - The tool setup must be rigid and aligned with the part.
 - Do not couple puller legs together. This reduces the tonnage capacity and increases the chance of tool or equipment damage.
 - Always use the shortest legs possible for an application to reduce the chance of tool or equipment damage.
 - Cover the tool setup and part with a protective blanket (see catalog) or canvas before applying force, because high forces exerted on the part being pushed or pulled can cause breakage.
 - Apply force gradually. The part should "give" a little at a time. Do not try to speed the operation by using an impact wrench on the forcing screw.
 - If maximum force has been applied, and the part has not moved, use a tool with a larger capacity. Do not hit the part with a hammer in an attempt to jar it loose.

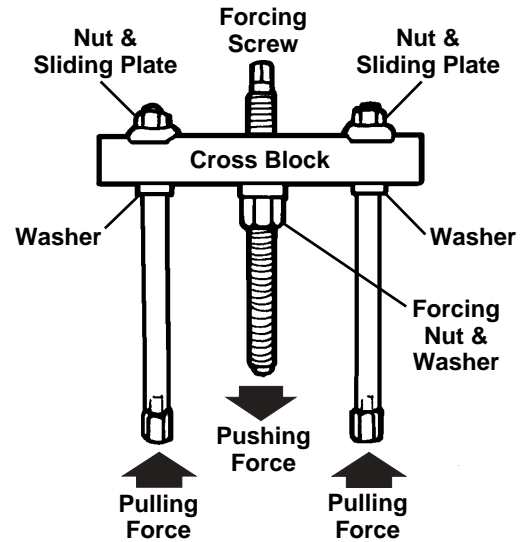

Figure 1

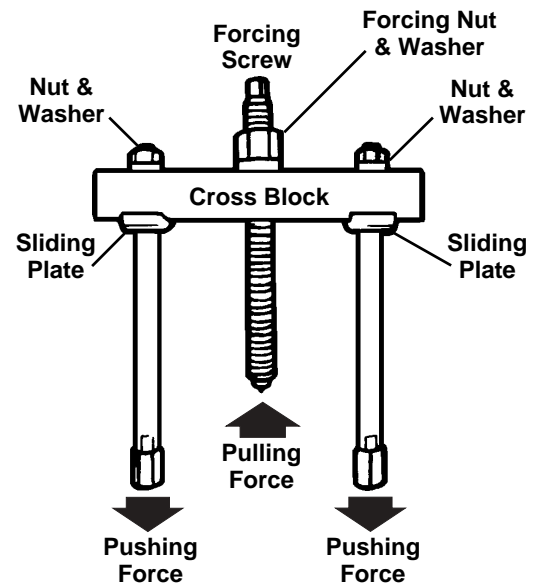

Figure 2