

PUTCO®

# MOLLE PANELS

- MODULAR LIGHTWEIGHT LOAD CARRYING EQUIPMENT -

## INSTRUCTION GUIDE

### CHEVROLET

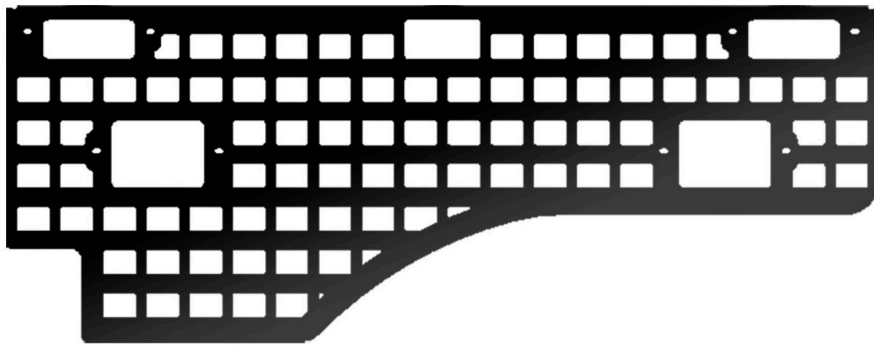

SIDE PANEL

Congratulations on your purchase of a high quality PUTCO® product. Should you need any application or technical assistance, feel free to call us at:

**1-800-247-3974**

Monday-Friday 8:00am - 5:00pm (Central Standard Time)  
Contact your PUTCO® dealer for other quality accessories.



**PLEASE READ ALL INSTRUCTIONS BEFORE INSTALLATION  
AND CHECK TO SEE THAT ALL PARTS ARE INCLUDED**

#### REQUIRED TOOLS

3/16" HEX KEY



T30 TORX DRIVE



FLATHEAD SCREWDRIVER



#### CONTENT LIST

DESCRIPTION	QTY
Molle Side Plate	1
Brackets	3
M6 Bolts	12
Tabbed Washer	3
5/16-18 X 2' Button Head Bolt	3
Threaded Nut Plate	3



## INSTALLATION INSTRUCTIONS

- 1** Begin by locating and removing the necessary plastic oval covers from the slots in the bed using a small flat-head screwdriver.
- 2** Next, loosely assemble a 5/16 bolt, tabbed washer, and nut plate to each bracket as shown.

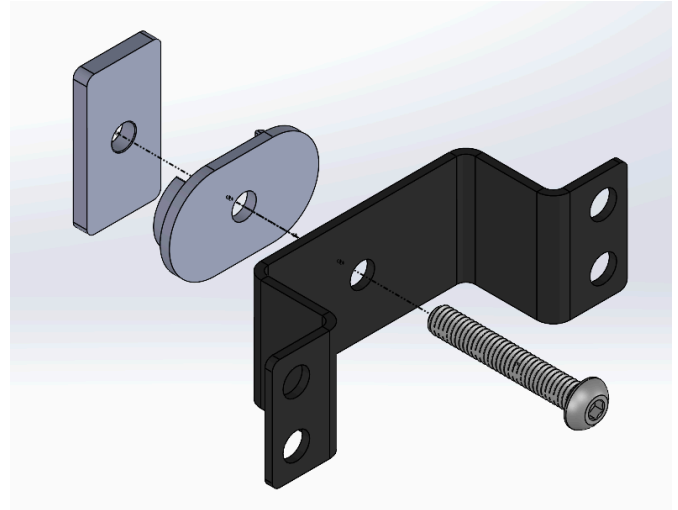

- 3** Grab one of the assembled brackets and insert the nut plate into one of the required bed slots. The nut plate will have to be inserted at an angle in order to fit. During this process, use caution so you do not loosen the nut plate and drop it behind the slot! Next, orient the nut plate so that it is perpendicular and centered behind the slot, then push the tabbed washer against the bed side so that the tabs fit into the slot. If aligned correctly, the tabs should prevent the nut plate from spinning. While keeping the tabbed washer in the slot pull back on the bolt and begin to tighten until snug, but do not fully tighten, as the position of the bracket may need to be adjusted. Repeat this process for the rest of the required slots in the bed.

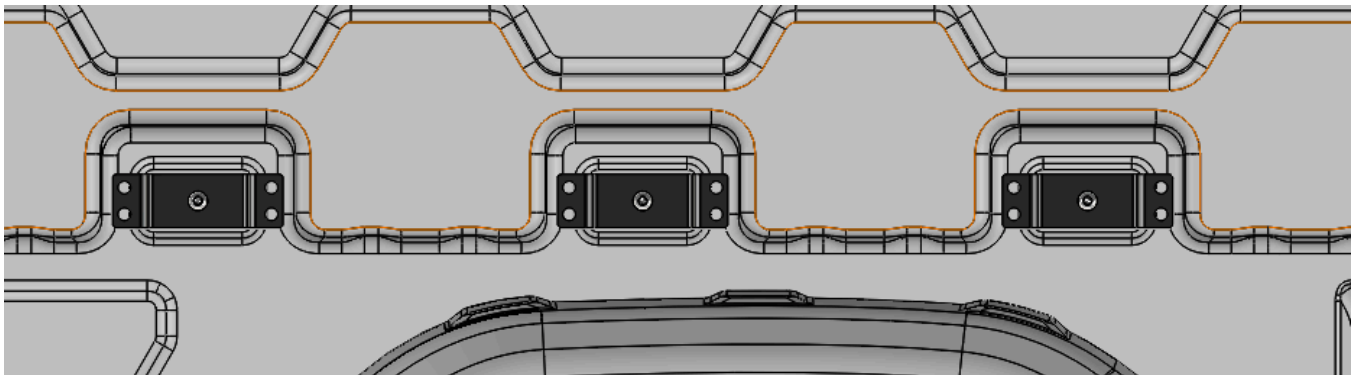

- 4** Attach the side plates to the brackets using the included M6 bolts. The brackets may have to be adjusted to get the holes to line up. The installed side plate should look like the figure below.



- 5** After the plate is in place, go back and make sure that all the bolts are tight, including the ones in the center of the bracket. All the bolts should be snug, but do not overtighten!

**Your new MOLLE Panel is now successfully installed on your vehicle!**