



**Sniper 4-Bolt GM LS 105mm Plate Kit Number 07162NOS**  
**Sniper 4-Bolt GM LS 90mm Plate Kit Number 07163NOS**



**OWNER'S MANUAL**

**P/N 199R11542**

**CONGRATULATIONS** on purchasing your Sniper Nitrous Oxide Injection System! It should provide many miles of trouble-free performance when used correctly. If you have any questions regarding the performance of your system, **call our Technical Service at 1-866-464-6553** or for online help, refer to the **Tech Service section of our website: [www.holley.com](http://www.holley.com)**

**NOTICE: The installation of Nitrous Oxide Systems, Inc. products signifies that you have read this document and have agreed to the terms stated within.**

It is the purchaser's responsibility to follow all installation instruction guidelines and safety procedures supplied with the product as it is received by the purchaser to determine the compatibility of the product with the vehicle or the device the purchaser intends to install the product on.

Nitrous Oxide Systems Inc. assumes no responsibility for damages occurring from accident, misuse, abuse, improper installation, improper operation, lack of reasonable care, or all previously stated reasons resulting from incompatibility with other manufacturers' products.

Nitrous Oxide Systems Inc. assumes no responsibility or liability for damages incurred by the use of products manufactured or sold by Nitrous Oxide Systems Inc. on vehicles used for competition or racing.

Nitrous Oxide Systems Inc. neither recommends nor condones the use of products manufactured or sold by Nitrous Oxide Systems Inc. on vehicles, which may be driven on public roads or highways, and assumes no responsibility for damages incurred by such use.

SNIPER nitrous oxide is legal for use in most states when used in accordance with state and local traffic laws. SNIPER does not recommend or condone the use of its products in illegal racing activities.

SNIPER has not pursued California Air Research Board (CARB) exemptions for its kits, hence, they are not legal for use on pollution-controlled vehicles in California. A correctly installed SNIPER nitrous system should not alter the emission control performance of your vehicle under standard EPA test cycle conditions.

## **HAZARDS DEFINED**

This manual presents step-by-step instructions that describe the process of installing your SNIPER Nitrous Oxide Injection System. These procedures provide a framework for the installation and operation of this kit. Parts are referenced by name and number to avoid confusion. Within the instructions, you are advised of potential hazards, pitfalls, and problems to avoid. The following examples explain the various hazard levels:

**WARNING! Failure to comply with instructions may result in injury or death.**

**CAUTION! Failure to comply with instructions may result in damage to equipment.**

**NOTE:** This information is important, needs to be emphasized, and is set apart from the rest of the text.

**HINT:** These special instructions provide a handy work tip.

## **NITROUS OXIDE INJECTION SYSTEM SAFETY TIPS**

### **WARNINGS**

**IT IS NOT LEGAL TO ENGAGE NITROUS OXIDE INJECTION SYSTEMS ON PUBLIC ROADS OR HIGHWAYS. NITROUS OXIDE INJECTION SYSTEMS ARE ONLY TO BE ENGAGED DURING SANCTIONED COMPETITION OR RACING EVENTS.**

**Do not attempt to start the engine if the nitrous has been injected while the engine was not running. Disable the ignition and fuel systems (consult owner's manual) and turn the engine over with the throttle wide open for several revolutions before attempting to start. Failure to do so can result in extreme engine damage.**

**Never permit oil, grease, or any other readily combustible substances to come in contact with cylinders, valves, solenoids, hoses, and fittings. Oil and certain gases (such as oxygen and nitrous oxide) may combine to produce a highly flammable condition.**

**Never interchange nitrous and fuel solenoids. Failure to follow these simple instructions can result in extreme engine damage and/or personal injury.**

**Never drop or violently strike the bottle. Doing so may result in an explosive bottle failure.**

**Never change pressure settings of safety relief valve on the nitrous bottle valve. Increasing the safety relief valve pressure settings may create an explosive bottle hazard.**

Please note that the SNIPER bottle label has changed to a two-part assembly. The first label is already located on the bottle. Upon filling your bottle with nitrous oxide, apply the (second) material information label in the area indicated in the picture to the right.

**NOTE:** The material information decal is located in the same plastic bag as the bottle.

**WARNING!** Once the nitrous bottle has been filled, it must be shipped according to the applicable transportation and shipping regulations!

Do not deface or remove any markings, which are used for content identification.

Nitrous bottle valves should always be closed when the system is not being used.

Notify the supplier of any condition that may have permitted any foreign matter to enter the valve or bottle.

Keep the valves closed on all empty bottles to prevent accidental contamination.

After storage, open the nitrous bottle valve for an instant to clear the opening of any possible dust or dirt.

It is important that all threads on the valves and solenoids are properly mated. Never force connections that do not fit properly.

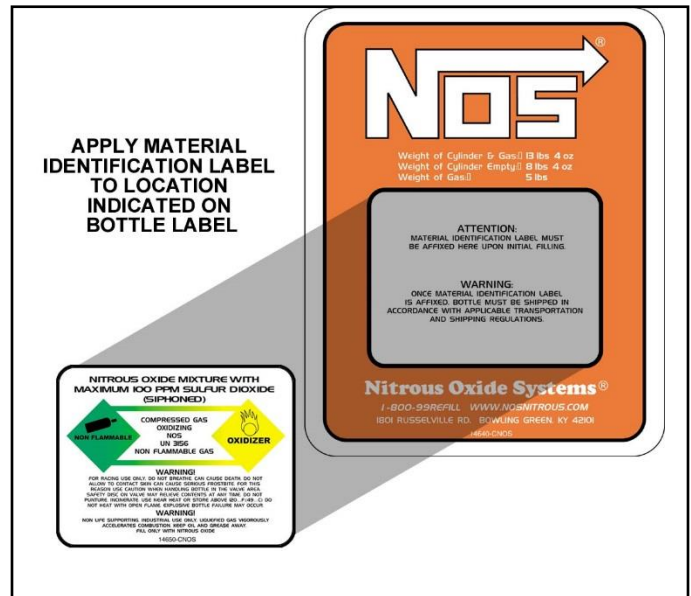

## TABLE OF CONTENTS

WHAT IS NITROUS OXIDE? .....	4
DO'S AND DON'TS OF NITROUS OXIDE .....	4
Chapter 1 Introduction to Your Sniper Nitrous Oxide Kit .....	4
1.1 General Information .....	4
1.2 System Requirements .....	5
1.3 Kit Components .....	5
Chapter 2 Kit Installation .....	7
2.1 Bottle Mounting Instructions .....	7
2.2 Bottle Orientation .....	7
2.3 Bottle Installation .....	7
2.4 Solenoid Fittings and Bracket Mounting .....	8
2.5 Kit Plate Installation .....	8
2.6 Fuel and Nitrous Supply Connection .....	9
2.7 Electrical System .....	10
Chapter 3 Tuning .....	12
Chapter 4 Determining Optimum System Performance .....	12
Chapter 5 Alternate Sensor, Actuator, and Switch Components .....	13
Chapter 6 Routine Maintenance .....	13
6.1 Nitrous Solenoid Filter .....	13
6.2 Nitrous Solenoid Plunger .....	13
6.2.1 General Information .....	13
6.2.2 Nitrous Solenoid Plunger Disassembly and Inspection .....	14
Appendix A Troubleshooting Guide .....	15
Nitrous Oxide Accessories .....	16

## WHAT IS NITROUS OXIDE?

### NITROUS OXIDE...

...Is a cryogenic gas composed of nitrogen and oxygen molecules

...Is 36% oxygen by weight

...Is non-flammable by itself

...Is stored as a compressed liquid

...Exists in two grades—U.S.P. and Nitrous Plus:

- ❑ U.S.P. is medical grade nitrous oxide; its common use is dental and veterinary anesthesia. It is also commonly used as a propellant in canned whipped cream. U.S.P. is not available to the public.
- ❑ Nitrous Plus differs from U.S.P. in that it contains trace amounts of Sulphur Dioxide added to prevent substance abuse. Nitrous Plus is intended for automotive applications and is available for sale to the public.

In automotive applications, Nitrous Plus and fuel are injected into the engine's intake manifold, producing the following results:

- ❑ Lowers engine intake air temperature, producing a dense inlet charge.
- ❑ Increases the oxygen content of the inlet charge (air is only 22 percent oxygen by weight).
- ❑ Increases the rate at which combustion occurs in the engine's cylinders.

## DO'S AND DON'TS OF NITROUS OXIDE

### Do's

- ❑ Read all instructions before attempting to install your SNIPER nitrous system.
- ❑ Make sure your fuel delivery system is adequate for the nitrous jetting you have chosen. Inadequate fuel pressure or flow will result in engine damage.
- ❑ Use 14 gauge (minimum) wire when installing electrical system components.
- ❑ Use high-quality connections at all electrical joints.
- ❑ Use PTFE-based paste on pipe-style fittings.
- ❑ Make sure your engine and related components (ignition, carburetor, and driveline) are in proper working condition.
- ❑ **Do not attempt to start the engine if the nitrous has been injected while the engine was not running. Disable the ignition and fuel systems (consult owner's manual) and turn the engine over with the throttle wide open for several revolutions before attempting to start. Failure to do so can result in extreme engine damage.**
- ❑ **Use your SNIPER nitrous system only at wide-open throttle and at engine speeds above 3000 RPM.**
- ❑ **Install a proper engine to chassis ground. Failure to do so may result in an explosive failure of the main nitrous supply line.**
- ❑ Use a high-quality fuel, as suggested in Chapter 3, Baseline Tuning Suggestions.

### Don'ts

- ❑ Engage your nitrous system with the engine off. Severe engine damage can occur.
- ❑ Modify SNIPER nitrous systems (if you need a non-stock item, call SNIPER Technical Service for assistance)
- ❑ Overtighten AN type fittings.
- ❑ Use PTFE Tape on any pipe threads. Pieces of PTFE tape can break loose and become lodged in the nitrous or fuel solenoids or solenoid filters. Debris lodged in a nitrous or fuel solenoid can cause catastrophic engine failure.

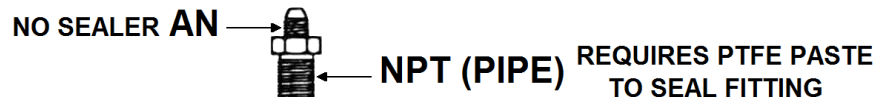

- ❑ Use sealant of any kind on AN type fittings.
- ❑ Allow nitrous pressure to exceed 1100 psi. Excessive pressure can cause swelling or in extreme cases failure of the nitrous solenoid plunger. Solenoid plungers are designed so that pressure-induced failures will prevent the valve from operating. No leakage should occur with this type of failure.
- ❑ **Inhale nitrous oxide. Death due to suffocation can occur.**
- ❑ **Allow nitrous oxide to come in contact with skin. Severe frostbite can occur.**
- ❑ **Use octane boosters that contain methanol. Fuel solenoid failure may occur, producing severe engine damage.**

## Chapter 1 Introduction to Your SNIPER Nitrous Oxide Kit

### 1.1 General Information

Kit Numbers 07163NOS & 07162NOS were engineered to be a clean, simple installation on the GM 4-Bolt 90mm & 105mm throttle body engines. Power output can be increased from 100 to 150 Rear Wheel Horse Power (RWHP) with the supplied jetting. The system can support up to 250 RWHP with optional jetting, and upgraded solenoids, but be aware that an increase over 150 RWHP will require an upgrade to the OEM fuel system in the form of an increased capacity fuel pump or a dedicated, stand-alone, fuel system.

This system was engineered for the GM LS engine that utilizes an 90mm or 105mm, 4 bolt cable operated throttle body. The wiring and electrical connections will need to be adapted to the different control system used.

## 1.2 System Requirements

When used correctly, Kit Number 07162NOS or 07163NOS is designed to work with stock GM LS internal engine and driveline components. The four jet combinations in this kit generate 100, 125, or 150 RWHP gains. Colder plugs (non-projected tip, non-platinum, Iridium or fine wire, gapped at .040") are recommended. If the jetting is increased over 150 HP, it is necessary to upgrade the fuel delivery system to ensure safe operation.

## 1.3 Kit Components

Before beginning the installation of your SNIPER kit, compare the components in your kit with those listed in **Table 1**. If any components are missing, please contact SNIPER Technical Support at 1-866-464-6553.

**Table 1 Kit Number 07162NOS & 07163NOS Parts List**

Item	Description	Quantity	SNIPER P/N
(1)	Bottle Nut Adapter	1	16220NOS
(2)	Bottle Valve Washer	1	16210NOS
(3)	10 lb. Orange Sniper Bottle	1	14740NOS
(4)	Bottle Mounting Bracket, Short	1	14126NOS
(5)	Bottle Mounting Bracket, Long	1	14127NOS
(6)	Sniper N <sub>2</sub> O Solenoid	1	18015NOS
(7)	Sniper Fuel Solenoid	1	18085NOS
(8)	Relay Wiring Harness	1	15604NOS
(9)	30 Amp Relay	1	15618NOS
(10)	3AN to 1/8-NPT 2 ft. Hose (Blue)	1	15060-1NOS
(11)	3AN to 1/8-NPT 2 ft. Hose (Red)	1	15060-2NOS
(12)	4AN – 1/8" NPT Filter Adapter (Blue)	1	15570NOS
(13)	4AN – 1/8" NPT Filter Adapter (Red)	1	15571NOS
(14)	0.031" Flare Jet	1	13760-31NOS
(15)	0.035" Flare Jet	1	13760-35NOS
(16)	0.044" Flare Jet	1	13760-44NOS
(17)	0.051" Flare Jet	1	13760-51NOS
(18)	0.055" Flare Jet	1	13760-55NOS
(19)	0.063" Flare Jet	1	13760-63NOS
(20)	4AN 14 ft. Hose (Blue)	1	15295NOS
(21)	<b>105mm LS 4-Bolt Plate Assembly</b>	1	40R887A
	OR		
(22)	<b>90mm LS 4-Bolt Plate Assembly</b>	1	40R818A
(23)	Socket Head Cap Screws	4	5R2524
(24)	Stainless Steel, M6 Washer	4	46R1506
(25)	<b>Gasket, LS 105mm</b>	1	8R2311
	OR		
(26)	<b>Gasket, LS 90mm</b>	1	8R2273
(27)	Solenoid Mounting Bracket	2	16505NOS
(28)	Basic Wire Pack	1	15612-VSNOS
	Rocker Switch	1	
	1/4" Ring Terminal – 18-20 AWG	1	
	1/4" Female Spade – 18-20 AWG	3	
	Wire – Red – 14AWG	8ft	
	Wire – Black – 14AWG	8ft	
	Microswitch	1	
	Microswitch Hardware	1	

**Figure 1 Kit Number 07162NOS & 07163NOS Component Identification**



**-Parts Shown are not to scale-**

## Chapter 2 Kit Installation

### 2.1 Bottle Mounting Instructions

Accurate calibration of your SNIPER nitrous system depends on the bottle remaining at a stable temperature. Mount the bottle away from heat sources, such as the engine compartment or exhaust system, and away from windows, where the bottle is exposed to direct sunlight.

### 2.2 Bottle Orientation

Bottle placement is critical to the performance of your SNIPER nitrous system. It is important to understand how the bottle valve and siphon tube are assembled to properly orient the bottle in your vehicle and ensure that it picks up liquid nitrous while undergoing acceleration. All nitrous bottles are assembled so that the bottom of the siphon tube is at the bottom of the bottle and opposite the bottle label (Figure 2).

Whenever the bottle is mounted in a lay-down position, the valve handle must be towards the front of the vehicle with the label facing up (Figure 3A).

If the bottle is mounted vertically, the valve handle and label must face toward the front of the vehicle (Figure 3B). This orientation will position the siphon tube at the back of the bottle where the liquid N<sub>2</sub>O will be during acceleration.

**WARNING! DO NOT attempt to remove the siphon tube without completely emptying the bottle of all N<sub>2</sub>O and pressure.**

A bottle mounted upside-down must have the siphon tube removed before use (Figure 3C).

If the bottle must be mounted parallel to the axles of the vehicle (sideways), the valve handle and label must be angled at approximately 45° toward the front of the vehicle (Figure 3D). This orientation will position the siphon tube toward the rear of the bottle.

**NOTE:** When using a bottle with a siphon tube, the tall bracket should be at the valve end of the bottle and the short bracket at the bottom (Figure 3E).

The most efficient mounting is the lay-down position (Figure 3A) with the valve handle toward the front of the vehicle. This position allows the greatest amount of liquid to be used before the siphon tube begins to pick up gaseous nitrous oxide.

Find a position in the rear of your vehicle that meets your personal preference. Make sure that it meets the guidelines show in Figure 3.

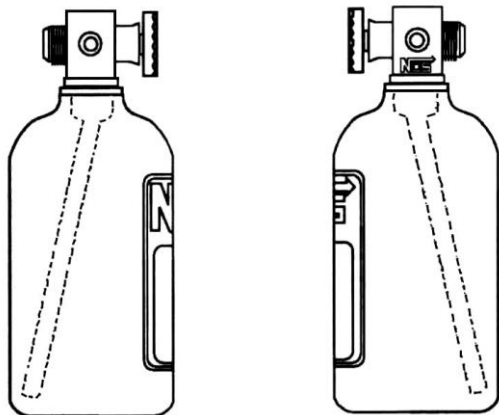

Figure 2 Nitrous Bottle Siphon Tube Orientation

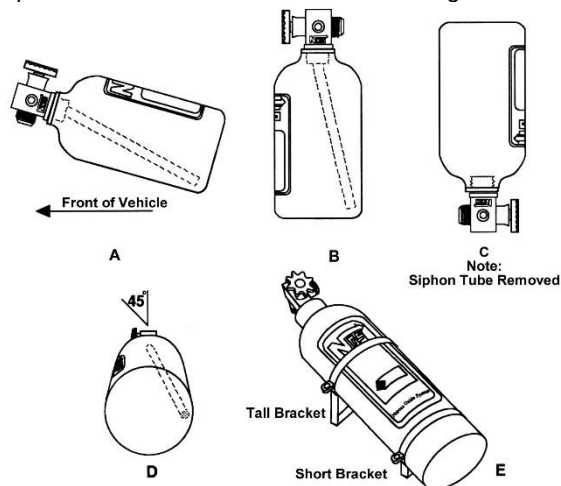

Figure 3 Nitrous Bottle Mounting Orientations

### 2.3 Bottle Installation

Before mounting a nitrous bottle in a racing vehicle intended for use in sanctioned events, check with the sanctioning association for any rules regarding this subject. Most associations require the bottle to be mounted within the confines of the safety roll cage with the safety pressure relief cap vented away from the driver's compartment. This feature is included in the 07162NOS & 07163NOS kit.

1. Install the bottle nut adapter and washer on the nitrous bottle, and tighten securely.
2. Slip the bottle mounting brackets onto the nitrous bottle, as shown in Figure 3E.



3. Locate the bottle assembly in the desired mounting location, ensuring that the location will provide easy access to the bottle valve, hose connection, bracket clamp bolts to facilitate bottle changing and through hole of the blow-down tube.
4. Use the assembled bottle/bracket unit as a pattern to mark for drilling the holes. Drill four 11/32" holes in the mounting surface for the bottle bracket bolts. **Make sure the holes are in a position that does not damage other components.**

**CAUTION!** When drilling or punching holes for these fasteners, be aware what components, wires, hoses or fluid reservoirs are located or routed behind the general area to avoid vehicle or equipment malfunction.

5. Mount the brackets securely to the surface (recommended minimum of 5/16" bolts or No. 12 sheet metal screws).
6. Secure the nitrous bottle in the mounting brackets and tighten the bracket clamps.
7. If the nitrous bottle is mounting within the passenger compartment we highly recommend the use of a nitrous blow down tube (16161NOS) and racer safety adapter (16169BNOS). Sold Separately.

## 2.4 Solenoid Fittings and Bracket Mounting

1. Apply a small amount of PTFE thread sealant to the NPT threads of the **nitrous filter fitting** (blue straight fitting with screen) and insert into the **IN** side of the blue nitrous solenoid. Use a bench vise to tighten the fitting at least 1-1/2 turns after finger tight. See **Figure 4** for alignment.
2. Apply a small amount of PTFE thread sealant to the NPT threads of the **nitrous outlet fitting** (small brass fitting with blue b-nut hose) and insert into the **OUT** side of the blue nitrous solenoid. Use a bench vise to tighten the fitting at least 1-1/2 turns after finger tight. See **Figure 4**.



**Figure 4**



**Figure 5**

3. Apply a small amount of PTFE thread sealant to the NPT threads of the **fuel filter fitting** (red straight fitting with screen) and insert into the **IN** side of the red fuel solenoid. Use a bench vise to tighten the fitting at least 1-1/2 turns after finger tight, **Figure 5**.
4. Apply a small amount of PTFE thread sealant to the NPT threads of the **brass hose end with red b-nut** and insert into the **OUT** side of the fuel solenoid. Use a bench vise to tighten the fitting at least 1-1/2 turns after finger tight, see **Figure 5**.

## 2.5 Kit Plate Installation

**WARNING!** Do not smoke, carry lighted tobacco, or allow an open flame of any type when working on or near any fuel-related components. Highly flammable mixtures are always present and may be ignited. Failure to follow these instructions may result in personal injury.

1. Disconnect negative cable at the battery.
2. Remove the engine cover (if equipped).
3. Disconnect the Intake Air Temp (IAT) Sensor, throttle body connection, and vacuum hose.
4. Using an 8mm or 5/16" nut driver, loosen the air inlet flex tube clamps. Remove the flex tube or entire air cleaner assembly.
5. Disconnect the TPS electrical connector.



- Using a 10mm socket, remove the throttle body bolts and set throttle body aside.
- Install the nitrous plate, gasket, and throttle body to the intake using the new, longer throttle body screws, see **Figure 6**.



**Figure 6**

- Assemble the nitrous plate supply lines to the appropriate fittings with the desired jets. (See Chapter 3, table 2 for suggested jetting). Route the supply lines and connect them to the appropriate solenoid.

**NOTE: We highly recommend the smallest (lowest power) jetting supplied as a starting point. Once total system functionality has been verified, then larger jetting can be installed.**

- Tighten the fittings and then the throttle body screws. Torque to 106 in./lbs. (~8.8 ft./lbs.).
- Reconnect the EVAP Purge valve electrical connector.

## 2.6 Fuel and Nitrous Supply Connection

If using the factory fuel system you will need an adapter, we recommend using the NOS Late Model Billet Fuel Line Adapter, part number 17002NOS.



**Figure 7 - NOS Late Model Billet Fuel Line Adapter (17002NOS)  
Sold Separately.**

**WARNING!** Fuel in the fuel system remains under high pressure even after the engine is shut off. Before working on or disconnecting any of the fuel lines or fuel system components, the fuel pressure must be relieved. Failure to follow these instructions may result in personal injury

## NOTE: FOR OEM FUEL SYSTEMS

1. Once residual fuel pressure is relieved, place clean rags under fuel rail feed line connector and disconnect by lifting the blue safety latch and pulling the lines apart. There may still be residual fuel in the lines.
2. Gently remove the OEM fuel supply line from the support clip on top of the driver's-side valve cover, rotate the clip 180° and reinsert the fuel line.
3. Install the NOS fuel tap between the fuel rail and the fuel feed line with the red fuel fitting pointing away from the firewall and install the redundant safety clip as shown.
4. Connect the fuel feed line (**Sold Separately**) coming from the fuel tap to the nitrous plate fuel fitting and tighten.
5. Plumb your nitrous supply line from the bottle to the blue -4AN straight fitting, **IN** side of the nitrous solenoid being careful not to pinch the line or allow any abrasion from moving parts in the vehicle or exposure to excessive heat.

## 2.7 Electrical System

Refer to the wiring schematic (Figure 8) for the electrical system installation.

**WARNING!** Death or injury may occur from working on a charged electrical system.

**NOTE: FOR LATE MODEL VEHICLES WE HIGHLY RECOMMEND USING THE MINI 2-STAGE PROGRESSIVE NITROUS CONTROLLER (15974NOS) SOLD SEPARATELY**

**WARNING!** Binding or dragging of the linkage will create a potentially dangerous stuck-throttle condition. Ensure that the microswitch does not interfere with normal throttle linkage operation.

**NOTE:** The microswitch may be mounted to the bracket in a variety of positions or on either side of the bracket. The bracket may be bent to suit the application.

1. Disconnect the car battery
2. Install the microswitch to trigger at wide-open throttle by adjusting the microswitch's position to ensure that the actuation arm of the microswitch "clicks" at the same point your linkage reaches wide-open against the throttle stop, (position A).
3. Ensure that the microswitch is activated by the accelerator pedal. Slowly press the throttle to the floor, while you listen for the "click" of the microswitch, (position B).

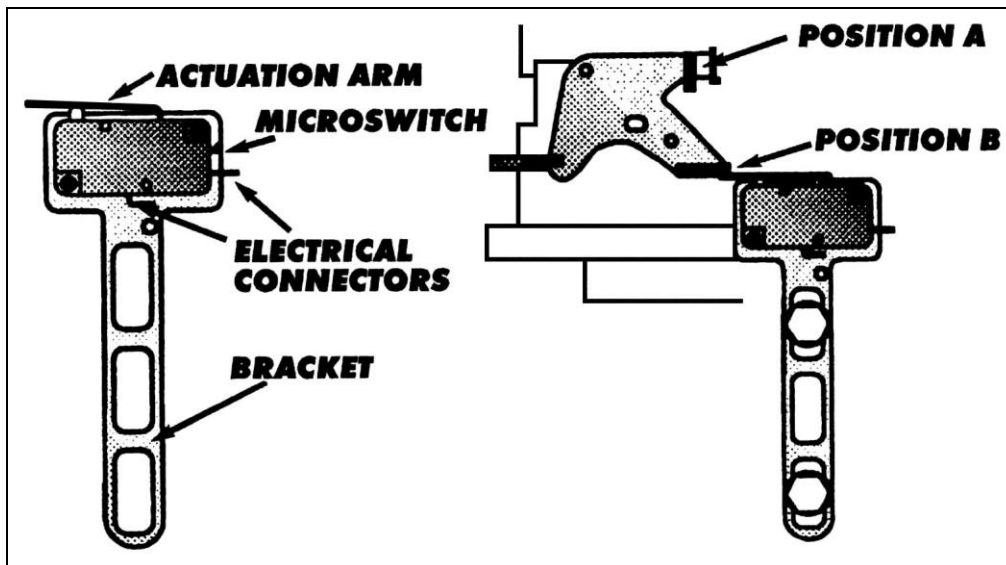

**Figure 8: Throttle Microswitch Installation**

4. Install the arming switch within easy reach of the driver.
5. Connect terminal #3 on the arming switch to an ignition switched +12V source, using the fused red wire provided.

**NOTE:** When selecting an ignition switched +12V source, ensure that your source is capable of handling the amperage of the fuse provided.

6. Connect terminal #2 of the arming switch to one post of the throttle microswitch (either post will do), with the blue wire provided.
7. Connect terminal #1 of the arming switch to ground. (You may elect to skip this step. If you do so, the light in the arming switch will not illuminate when the system is armed).
8. Connect the open post of the microswitch to one wire from each solenoid (either wire will do, the solenoids are not polarity specific), using the blue wire provided.
9. Connect the open wire from each solenoid to ground.

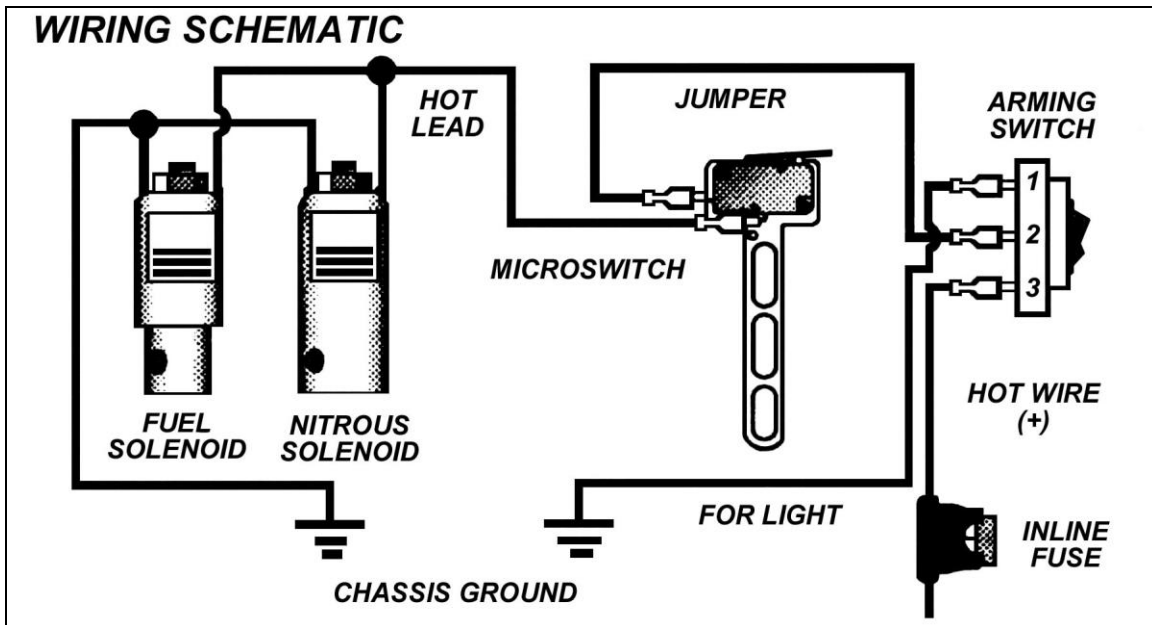

Figure 9: Wiring Schematic

## 2.8 Preparing for Operation

1. Install a fully charged nitrous bottle. The pressure gauge should read 900-1000 psi at operating temperature/pressure.
2. Slowly open the nitrous bottle valve while listening and looking for any leaks at the bottle fittings as well as the fittings on the solenoids in the engine compartment.
3. If no leaks are found, slightly loosen the -4 AN supply line fitting at the blue nitrous solenoid. Allow the air to leak from the fitting until nitrous starts to fog out, then retighten the fitting. **NOTE: Nitrous is very cold and can cause burning and irritation to the skin, we recommend wearing gloves during this procedure.**
4. Your nitrous system is now primed and ready.

**WARNING!** It is VERY important to use caution and good safety practices when testing and using any nitrous oxide system. We do not recommend the use of nitrous on any public streets or highways. It is recommended to only test and use nitrous in a controlled, closed course location, such as a race track.

**WARNING!** Never activate nitrous with the vehicle in "NEUTRAL" or "PARK"!

**WARNING!** Never activate nitrous at engine speeds below 3000 RPM, or engine damage may result!

**WARNING!** SEVERE ENGINE DAMAGE MAY OCCUR IF NITROUS IS ACTIVATED WHILE TRACTION CONTROL DEVICES ARE ENABLED. TRACTION CONTROL DE-ACTIVATION MUST BE CYCLED EVERY TIME THE IGNITION SWITCH IS CYCLED.

## Chapter 3 Tuning

Table 2 Tuning Suggestions for SNIPER Kit Number 07162NOS & 07163NOS

Configuration	N <sub>2</sub> O Jetting	Fuel Jetting
100 RWHP*	51*	31*
125 RWHP*	55*	35*
150 RWHP**	63*	44*

\*Jetting Included in kit

\*\*Will require an upgraded fuel system

**NOTE:** It is recommended to install one to two steps colder, non-Iridium or other fine wire spark plugs when using Nitrous Oxide.

## Chapter 4 Determining Optimum System Performance

The jetting combinations included in your 07162NOS & 07163NOS kit are intended to generate power gains of 100-150 HP. These combinations are designed to be used with 950 psi of nitrous bottle pressure and 60 psi of flowing fuel pressure. Spark plug inspection and/or the use of a wide-band O<sub>2</sub> sensor can determine optimum system performance. Inspection of the spark plugs should be done on a consistent basis.

1. Perform a dynamometer pull or a full throttle pass down the racetrack. Note the power reading or vehicle mph (not e.t.). Examine the spark plugs for an indication of lean or rich nitrous/fuel conditions (refer to for tips on reading the spark plugs). For this application, the air/fuel mixtures at WOT tend to be very rich in stock form. You may wish to examine a plug after a NO-nitrous pass or dyno pull for comparison purposes.

**CAUTION!** Terminate test immediately if pinging, knocking, detonation is noticed during the test. If engine does not pull hard (expected HP or torque gains are not observed), terminate test and investigate before continuing.

- 1A. If spark plugs appear to be excessively rich, decrease the fuel jet size 1 step (ex. 28 to 26 or 26 to 24).
  - 1B. If spark plugs appear to be excessively lean, increase the fuel jet size 1 step.
  - 1C. If spark plugs have a "like new" appearance on the porcelain and electrode, do not make a fuel jetting change.
2. Repeat these steps until the desired mixture is obtained.

### How to Read Spark Plugs from a Nitrous Oxide Injected Engine

#### A. Correct Timing, Mixture, and Spark Plug Heat Range

The ground strap retains a "like new" appearance. The edges are crisp, with no signs of discoloration. The porcelain retains a clear white appearance with no "peppering" or spotting.

#### B. Excessively Rich Mixture

The porcelain may be fuel stained, appearing brown or black. In extreme cases, the ground strap, electrode, and porcelain may be damp with gasoline, or smell of fuel.

#### C. Detonation

The edges of the ground strap may become rounded. The porcelain has the appearance of being sprinkled with pepper, or may have aluminum speckles. During heavy detonation, the ground strap tip may burn off. This phenomenon can result from excessive ignition timing, too high a heat range spark plug, inadequate fuel octane, or excessively lean mixture.

#### D. Excessively Lean Mixture

The edges of the ground strap may become rounded. Under moderate overheating, the tip of the ground strap can discolor, usually turning purple, or the entire ground strap can become discolored.

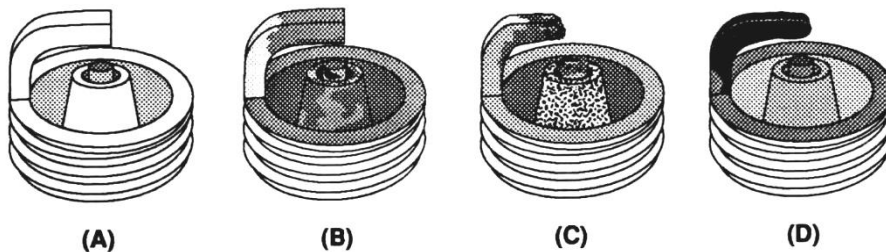

Figure 10 Spark Plug Condition

## Chapter 5 Alternate Sensor, Actuator, and Switch Components

1. In some racing applications, “pushbutton solenoid” activation is preferred. In such instances, the solenoid is connected to ground via a pushbutton momentary switch P/N 15610NOS. For information on wiring options, please call **NOS Technical Support at 1-866-464-6553**.
2. Almost all multi-point fuel injection systems are provided with throttle position sensors. NOS has throttle position sensor controllers that activate the solenoids, according to the sensor voltage output. This form of solenoid activation procedure is commonly referred as “TPS activation”. Such devices are more accurate than the microswitch. For P/Ns on TPS switches and information on wiring options, please call **NOS Technical Support at 1-866-464-6553**.
3. NOS offers fuel pressure safety switches. These switches only allow the nitrous and fuel solenoid to be activated, if a safe fuel pressure is existent in the enrichment fuel supply system. For information on pressure safety switches and information on wiring options, please call **NOS Technical Support at 1-866-464-6553**.
4. Activation of nitrous at low RPM levels can be detrimental to the engine performance and engine life. The RPM window activation switch only allows the nitrous and fuel solenoid to be activated if a safe RPM value has been reached. Some factory engine control units cut off the ignition if a maximum RPM level is reached. Although the engine is still at WOT and the solenoids are activated no nitrous and fuel is combusted. When the engine reaches safe RPM levels ignition is restored but excess fuel and nitrous are present in the manifold. Some applications may even cut the fuel injector to limit engine RPM. Because the engine is at WOT, the nitrous solenoid is still open thus generating an extreme lean condition. Under both conditions engine damage might occur. The RPM window activation switch cuts off the supply of fuel and nitrous until safe RPM levels are reached. The low and high RPM values can be trimmed according to the application. For information on pressure safety switches and wiring options, please call **NOS Technical Support at 1-866-464-6553**.

## Chapter 6 Routine Maintenance

### 6.1 Nitrous Solenoid Filter

When nitrous bottles are refilled, they can become contaminated with debris if the refiller does not have adequate filtration in his transfer pump mechanism. Contaminants in the bottle will eventually become lodged in the nitrous solenoid filter fitting.

**Call 1-800-99-REFILL (1-800-997-3345) for bottle refill location information.**

You should periodically (after every 20-30 pounds of nitrous usage) examine the mesh in the nitrous filter (sold separately) for debris.

To clean the filter, follow the following steps:

1. Close the valve on the nitrous bottle.
2. Empty the main nitrous feed line.
3. Disconnect the main nitrous feed line from the nitrous solenoid.
4. Remove the nitrous filter fitting from the nitrous solenoid.
5. Remove **all** PTFE paste debris from the solenoid inlet port threads and from the nitrous solenoid filter pipe threads.
6. Examine the mesh in the nitrous filter fitting for contaminants. Blow out debris with compressed air, if necessary.
7. Apply fresh PTFE paste to the nitrous filter pipe threads. Reinstall the filter in the nitrous solenoid.
8. Reconnect the main nitrous supply line to the nitrous solenoid.

### 6.2 Nitrous Solenoid Plunger

#### 6.2.1 General Information

The seals used in SNIPER nitrous solenoid plungers are constructed from materials which are designed to be used with nitrous oxide. When kept free from fuel contaminants or from over pressurization, they should provide trouble free performance.

You should periodically (after every 20-30 pounds of nitrous usage) examine the seal in the nitrous solenoid plunger.

The seals used in SNIPER nitrous solenoid plungers are designed to work at pressures up to 1100 psi. Exposing the plunger to excessive pressure (whether the vehicle is sitting or in-use) can result in the seal in the plunger swelling or in extreme cases disintegrating.

**NOTE:** The seals are designed so that if they fail due to over pressurization, they will not leak, the valve will just fail to flow nitrous oxide.

Swelling of the nitrous solenoid plunger seal will reduce nitrous flow (causing an excessively rich nitrous/fuel condition and a loss of power).

### **6.2.2 Nitrous Solenoid Plunger Disassembly and Inspection**

1. Close the valve on the nitrous bottle.
2. Empty the main nitrous supply line.
3. Remove the retaining nut from the nitrous solenoid.
4. Remove the coil and housing from the nitrous solenoid base.
5. Unscrew the stem from the nitrous solenoid base. Do this by double nutting the stem, or by using a solenoid stem removal tool. **Do not use pliers on the solenoid stem. Damage to the stem will result.**
6. Remove the stem, spring, and plunger from the solenoid base.
7. Examine the plunger seal for swelling. The seal surface should be flat, except for a small circular indentation in the center of the seal;

A fuel-contaminated seal will protrude from the plunger and be dome-shaped. A fuel-contaminated seal may return to its original shape if left out in the fresh air for several days. It may then be returned to service.

A seal, which has been over-pressurized, may be dome-shaped, or the sealing surface may be flat with the seal protruding out of the plunger. A dome-shaped seal may return to its original shape if left out in the fresh air for several days. It may then be returned to service. A seal, which is flat, but protrudes from the plunger body has probably failed internally and should be replaced.

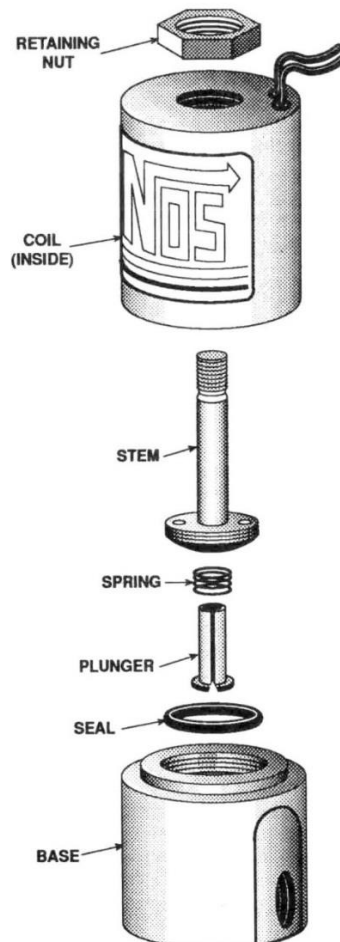

**Exploded View of a Typical Solenoid**

### Appendix A Troubleshooting Guide

The troubleshooting chart on the following pages should help determine and rectify most problems with your installed SNIPER system. If you still need assistance determining or fixing problems, call SNIPER Technical Support Department at 1-866-464-6553.

PROBLEM	POSSIBLE CAUSES	DIAGNOSTIC PROCEDURE	CORRECTIVE ACTION
No change in engine speed when the system is activated.	System wired incorrectly.	Compare wiring to schematic.	Wire per instructions.
	Restricted fuel line.	Inspect fuel line for restrictions (crimped or plugged).	Remove restrictions.
	Malfunctioning fuel solenoid.	Remove and inspect solenoid.	Repair/replace solenoid.
	Malfunctioning nitrous solenoid.	Remove and inspect solenoid.	Repair/replace solenoid.
Engine runs rich when system is activated.	Bottle valve not fully opened.	Check bottle valve.	Open valve fully.
	Bottle mounted improperly.	Check bottle orientation.	Mount bottle properly.
	Plugged nitrous filter.	Inspect filter.	Clean/replace filter.
	Low bottle pressure.	Check bottle temperature.	Set bottle temperature to 80° to 85°F.
	Inadequate nitrous supply.	Weigh bottle.	Fill bottle. 1-800-997-3345 for refills nearest you.
	Mismatched N <sub>2</sub> O/fuel jetting.	Compare jetting to recommended values.	Install correct jets.
	Excessive fuel pressure.	Install fuel pressure gauge in the fuel line. Measure the pressure during acceleration, with the system activated.	Regulate pressure down, or install smaller fuel jetting.
	Loose nitrous solenoid wiring.	Inspect the solenoid wiring.	Repair wiring.
Malfunctioning nitrous solenoid.	<b>WARNING:</b> Solenoid discharges nitrous at a high rate. Don't inhale nitrous; death may occur. Skin contact may cause frostbite. Close bottle valve. Disconnect the solenoid outlet port. Disconnect the solenoid (+) lead. Open the nitrous bottle valve. Briefly connect the +12V to the solenoid. Solenoid should discharge N <sub>2</sub> O at a high rate.	Repair/replace solenoid.	
No change in performance when system is activated.	System wired incorrectly.	Compare nitrous wiring to schematic.	Wire system per instr.
	Loose ground wire(s).	Connect 12V test light to battery (+) terminal. Check for continuity at grounds noted in schematic.	Tighten/repair loose ground(s).
	No power to arming switch.	With vehicle ignition on, connect 12V test light to battery (-) terminal. Check for power at pole #1 on arming switch.	Repair wiring.
	Damaged fuse in switched power (15 amp)	Remove and inspect 15 amp fuse	Replace Fuse
	Damaged fuse in solenoid relay battery power (30 amp)	Remove and inspect 30 amp fuse	Replace Fuse
	Malfunctioning arming switch.	With vehicle ignition on, turn arming switch ON. Connect 12V test light to battery (-) terminal. Check for power at red wire on arming switch.	Replace arming switch.
Engine detonates mildly when system is activated.	Overly rich fuel condition.	Check for black smoke or backfiring through exhaust with system activated.	Install smaller fuel jet or check for restriction in fuel supply.
	Inadequate octane fuel.		Use higher octane fuel; up to 116VPC-16.
	Incorrect spark plug type or heat range.	Do not use "fine wire" or iridium type spark plugs. Reduce spark plug heat range by 1 or 2 steps.	Replace spark plugs with correct type and heat range.
Engine detonates heavily	Too much nitrous flow.		Reduce nitrous jetting.



when system is activated.	Inadequate fuel delivery due to restricted fuel filter.	Inspect fuel filter.	Clean or replace filter.
	Crimped fuel line.	Inspect fuel line.	Replace crimped line.
High rpm misfire when system is activated.	Weak fuel pump.	Install fuel pressure gauge. Run engine under load at wide-open throttle, with system activated.	Repair/replace fuel pump.
	Excessive spark plug gap.	Inspect spark plugs.	Set spark plug gap at 0.030" to 0.035".
Surges under acceleration when system is activated.	Weak ignition/ignition component failure.	Inspect components (plug wires, coils, etc.)	Replace worn components.
	Inadequate supply of nitrous.	Check bottle weight.	Replace with full bottle.

## Nitrous Oxide Accessories

SNIPER systems are calibrated for optimum performance with a bottle pressure of 950 psi. The pressure will change with temperature. Heater kits are thermostatically controlled to keep the bottle near 85° F to provide correct pressure. **Bottle Heater (P/N 14164SNIPER)** is available for 10 & 15 lb. bottles. **Bottle Heater, P/N 14169SNIPER**, is pressure-controlled to keep your bottle at 950 psi.

Insulating the bottle helps maintain pressure by keeping heat in the bottle when it's cold, or heat out when it's hot outside. The blankets are made of a rugged, easily cleaned Nylon outer shell with insulation. It's also an excellent "dress up" accessory and perfect for "covering" battle-scarred bottles. **Bottle Blanket (P/N 14165SNIPER)** is a 7" diameter blanket for the 10 lb. bottle.

#10 Bottle Heater P/N 14169NOS



#10 Bottle Blanket P/N 14165NOS



The **Nitrous Pressure Gauges, P/N 15910SNIPER (-4AN lines) or P/N 15912SNIPER (-6AN lines)** [0-1500 PSIG] are designed to provide accurate ( $\pm 2\%$  of full scale) readings of fuel pressure in carbureted applications.

The **Fuel Pressure Gauges, P/N 15906SNIPER** [0-120 PSIG] and **P/N 15900SNIPER** [0-15 PSIG] are engineered to provide accurate ( $\pm 2\%$  of full scale) readings for high and low fuel pressure applications.

Nitrous & Fuel Pressure Gauges



**SNIPER Technical Support**  
**Toll-Free Phone: 1-866-464-6553**  
**Phone: 1-270-781-9741**

**For refill information:**  
**1-800-99-REFILL (1-800-997-3345)**

**199R11542**  
**Date: 4-4-17**