

## Ford 4.6L 3-Valve Plate System Supplemental Instructions PN 20947

Follow the Stage 1 EFI instructions for the installation of the bottle mounting, testing, safety, and tuning tips. The following images and text will show the installation of the Ford 3-Valve Plate nitrous, fuel delivery unit.

1. Remove the air boot between the Mass-Air Sensor and Throttle Body.
2. Disconnect the IAC and TPS, and Throttle Motor sensors.
3. Now remove the throttle body from the intake manifold.
4. Install the plate between the throttle body and intake manifold. You *must* use the supplied gaskets on BOTH sides of the plate. Plate engraving must be on the top, as well as the solenoid on the passenger side of the car as shown in illustration 1. Torque bolts to factory specs. Do not overtighten.
5. Install the supplied Ford Fuel Rail Adapter below the Fuel Pressure Sending Unit on the Drivers side fuel rail.
6. The Fuel Rail Adapter has 2-1/8npt holes. Install the 1/8xD-4 Fitting in one, and the 1/8npt hex plug in the other. NX Thread Sealer must be used on the pipe threads. DO NOT USE ON FLARE SIDE of fitting.
7. Install the desired jet in the Fuel fitting in the Plate. Connect Plate Fuel Fitting to the d-4 fitting in your Ford Fuel Rail Adapter.
8. Illustration 3 shows assembly of WeatherPack connections. These are supplied and should be installed where the Wiring Diagram indicates.
9. For wide open throttle activation, find the YELLOW wire on your TPS sensor. Splice into the wire using the supplied T-Tap.
- 9.. Now following the wiring schematic, double check the wiring and refer to the “Testing and using the system” Section of your Stage 1 EFI instructions to finish the installation.

**Illustration 1**

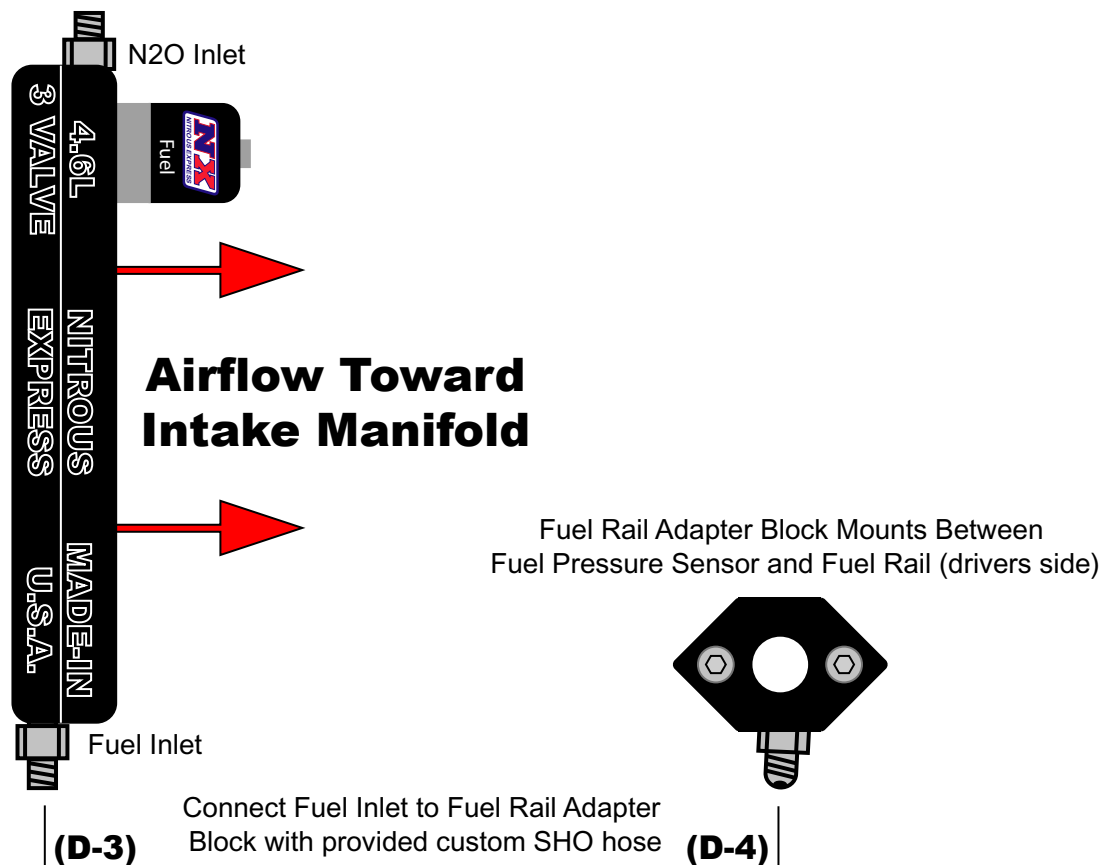

# Wiring Diagram

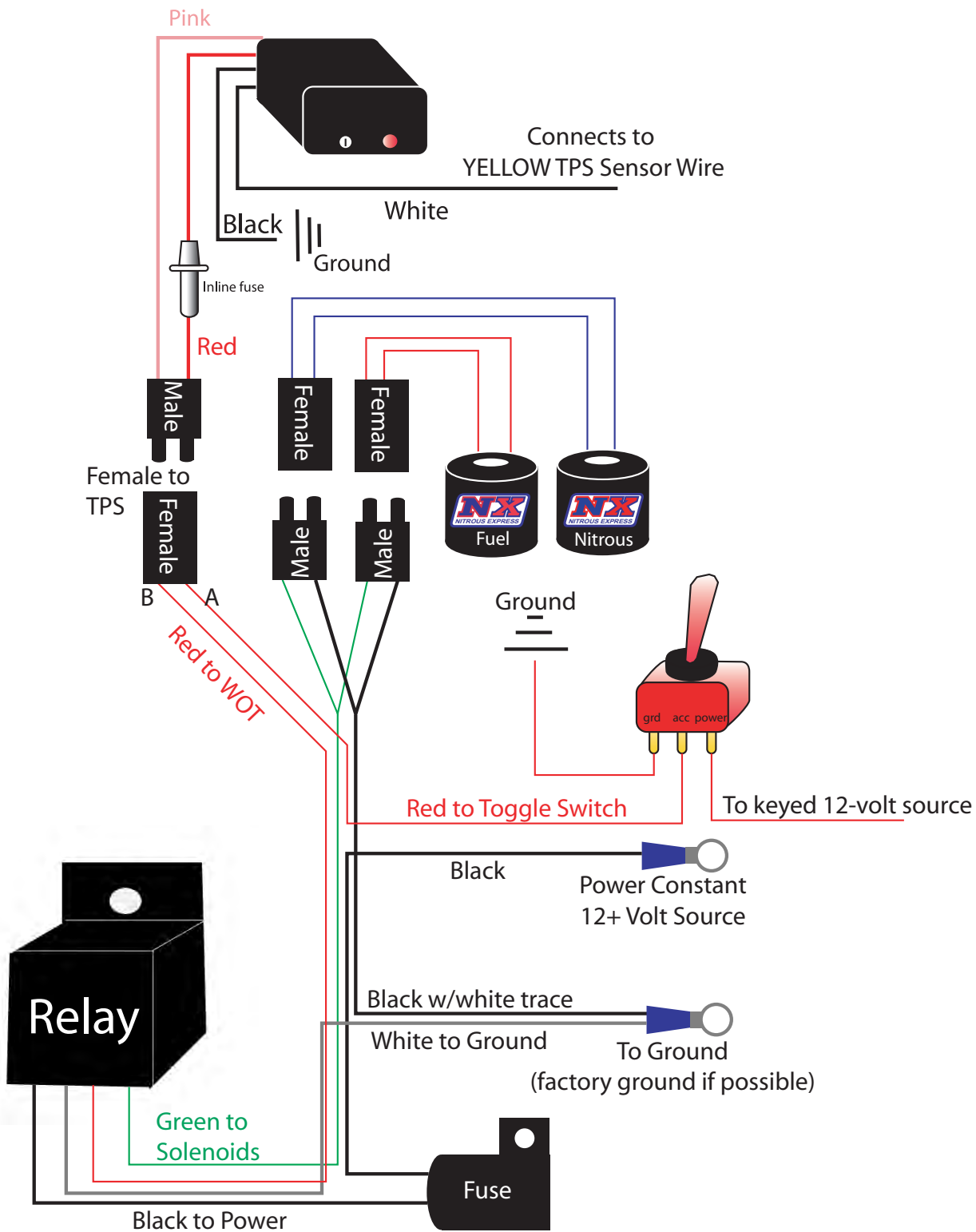

Illustration 3





